

EN

Original Instructions
Version 2
December 2024

DRAPER[®]

4 TONNE & 10 TONNE **BODY REPAIR KITS**

13590 & 13930



13590



13930

**UK
CA** **CE**

1. Preface

These are the original product instructions. This document is part of the product; retain it for the life of the product, passing it on to subsequent holders. Read this manual in full before attempting to assemble, operate or maintain this product.

This Draper Tools manual describes the purpose of the product and contains all the necessary information to ensure its correct and safe use. Following all the instructions and guidance in this manual will ensure the safety of both the product and the operator and increase the lifespan of the product.

All photographs and drawings within this manual are supplied by Draper Tools to help illustrate correct operation of the product.

Every effort has been made to ensure the information contained in this manual is accurate. However, Draper Tools reserves the right to amend this document without prior warning. Always use the latest version of the product manual.

1.1 Product Reference

User Manual for: 4 Tonne And 10 Tonne Body Repair Kits

Stock No: 13590 & 13930

Part No: BRKIT4 & BRKIT10

1.2 Revisions

Version 1: November 2023

First release

Version 2: December 2024

As our manuals are continually updated, always ensure that the latest version is used.

Please visit [drapertools.com/manuals](https://www.drapertools.com/manuals) for the latest version of this manual and the associated parts list, if applicable.

1.3 Understanding the Safety Content of This Manual



WARNING! – Situations or actions that may result in personal injury or death.



CAUTION! – Situations or actions that may result in damage to the product or surroundings.

Important: – Information or instructions of particular importance.

1.4 Copyright © Notice

Copyright © Draper Tools Limited.

Permission is granted to reproduce this manual for personal and educational use **ONLY**. Commercial copying, redistribution, hiring or lending is strictly prohibited.

No part of this manual may be stored in a retrieval system or transmitted in any other form or means without written permission from Draper Tools Limited.

In all cases, this copyright notice must remain intact.

1. Preface	2
1.1 Product Reference	2
1.2 Revisions	2
1.3 Understanding the Safety Content	2
1.4 Copyright © Notice	2
2. Contents	3
3. Product Introduction	4
3.1 Intended Use	4
3.2 Specification	4
3.3 Explanation of Symbols	4
4. Health and Safety Information	5
4.1 General Safety Warnings	5
4.2 Work Area	5
4.3 Personal Safety	5
4.4 Tool Use and Care	5
4.5 Service	5
5. Identification and Unpacking	6
5.1 Product Overview	6
5.2 What's in the Box?	7
5.3 Packaging	7
6. Operating Instructions	8
6.1 Ram attachments	8
6.2 Spreader Set Up - Fig. 1	8
6.3 Ram Set Up - Fig. 2	9
6.4 To operate the pump - Fig. 3 & 4	10
6.5 To operate the ram	10
6.6 To operate the spreader	10
7. Maintenance and Troubleshooting	11
7.1 Cleaning and Maintenance	11
7.2 Filling and Bleeding Hydraulic Fluid	11
7.3 Troubleshooting	12
8. Spares, Returns and Disposal	13
9. Warranty	14

3. Product Introduction

3.1 Intended Use

This body repair kit is designed for use in garages or bodywork workshops.

Any other application beyond the conditions established for use will be considered misuse. Draper Tools accepts no responsibility for improper use of this product.

Read this manual in full before assembling, operating or maintaining the product and retain it for later use.

3.2 Specification

Stock No.	13590	13930
Part No.	BRKIT4	BRKIT10
Safe working load	4 Tonne	10 Tonne
Ram max. height	387mm	452mm
Ram min. height	267mm	322mm
Stroke height	120mm	130mm
Pump working pressure	56.5 Mpa	63 Mpa
Pump oil capacity	420ml	650ml
Spreader max load	0.5 Tonne	0.5 Tonne
Ram Toe & Plunger Toe max load	0.5 Tonne	0.8 Tonne

3.3 Explanation of Symbols



Read the instruction manual



Max. load capacity



Do not abandon in the environment



Stroke



WARNING!



Do not incinerate or throw onto fire

4.1 General Safety Warnings



WARNING! Read all safety warnings and instructions. Failure to heed these warnings may result in personal injury and/or property damage. Save all warnings and instructions for future reference.

Important: The warnings, precautions and instructions discussed in this manual cannot cover all possible conditions and situations that may occur. It must be understood by the operator that common sense and caution are factors which cannot be built into this product but must be supplied by the operator.

4.2 Work Area

- **Turn off the engine, set the parking brake and block the tyres before working on a vehicle. Keep the work area clean and well lit.** Cluttered benches and dark areas increase the risk of injury to persons.
- **Keep bystanders and children away while operating the tool.** Distractions can result in loss of control of the tool.
- **ONLY** use this product on a stable, level and dry surface, which is capable of taking the load.
- **DO NOT** use this product as a vehicle lifting device or as a vehicle support.

4.3 Personal Safety

- **Stay alert. Watch what you are doing and use common sense when operating the tool. DO NOT use the tool while tired or under the influence of drugs, alcohol or medication.** A moment of inattention while operating the tool increases the risk of injury to persons.



WARNING! Keep your hands, body and clothing away from the repair kit and accessories when in use.

- **Dress properly. Do not wear loose clothing or jewellery. Contain long hair and keep hair, clothing and gloves away from moving parts.** Loose clothes, jewellery or long hair increases the risk of injury to persons as a result of being caught in moving parts.
- **Use safety equipment.** Wear safety goggles and heavy-duty work gloves during use.

4.4 Tool Use and Care

- Care must be taken when handling this product as dropping this tool could result in personal injury.
- Environmental conditions can have a detrimental effect on this product if neglected.
 - Exposure to damp air can gradually corrode components.
 - If the product is unprotected from dust and debris, components will become clogged.
- If not cleaned and maintained correctly or regularly, the tool will not perform at its best.
- **DO NOT force the tool.** Use the correct tool for the application as it will do the job better and safer at the rate for which the tool is designed.
- **Store the tool when not in use out of reach of children and other untrained persons.** A tool is dangerous in the hands of untrained users.
- **Check for misalignment or binding of moving parts, breakage of parts and any other condition that affects the tool's operation.** If damaged, have the tool serviced before using. Many accidents are caused by poorly maintained tools.
- **Use only accessories that are identified by the manufacturer for the specific tool model.** Use of an accessory not intended for use with the specific tool model, increases the risk of injury to persons.
- **Avoid off-centre loads.** If the pump seems unusually hard to operate, immediately stop. Adjust the ram to eliminate or diminish an off-centre load. The ram toe and plunger toe must **ONLY** be used together to prevent an off-centre load.
- **Protect the Hose.** Do not drop heavy objects on the hose. Avoid kinks in the hose. Maintain proper clearance to avoid damage to the hose and couplers.
- **Inspect repair before using vehicle.** Repairs to structural or frame members must be inspected by a qualified technician to ensure that the structure is still strong enough to safely fulfil its potential.

4.5 Service

Tool service must be performed only by qualified repair personnel.

When servicing a tool, use only identical replacement parts. Use only authorised parts.

5. Identification and Unpacking

5.1 Product Overview

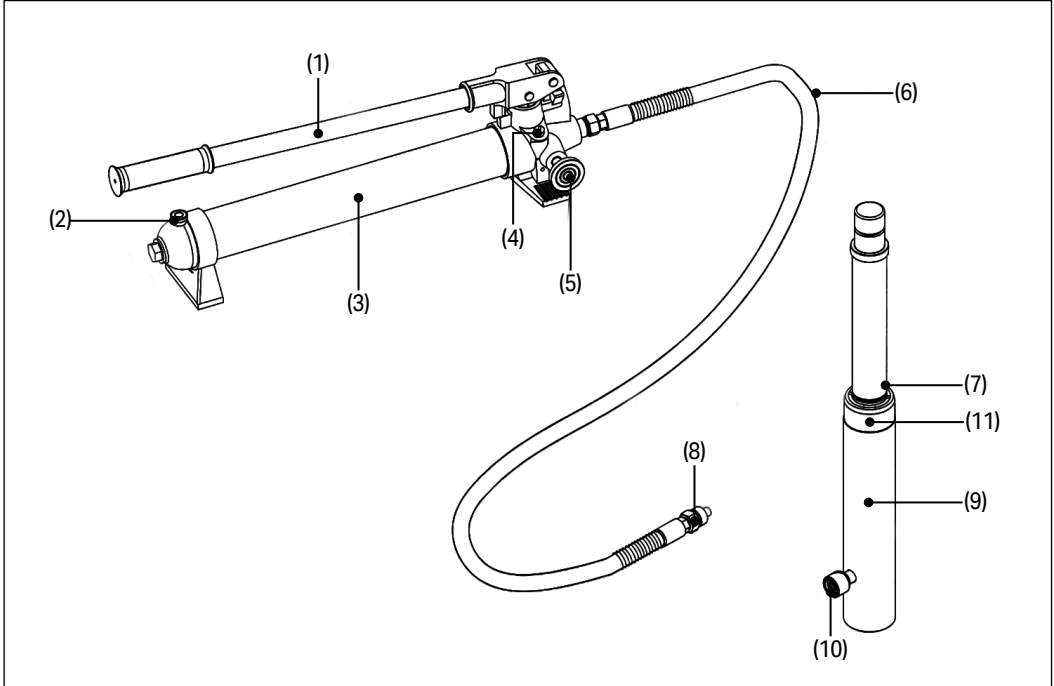

- | | |
|----------------------|---------------------|
| (1) Handle | (7) Warning Line |
| (2) Oil Filler Screw | (8) Hose Coupler |
| (3) Pump | (9) Ram |
| (4) Safety Valve | (10) Ram Coupler |
| (5) Release Valve | (11) Protection Cap |
| (6) Hose | |

WARNING!

- **Ensure** that the rated working pressure of each pressurised attachment is equal to or greater than the rated working pressure produced by the hydraulic pump.
- Always **check** connections before using. Alteration of these products is strictly prohibited. Use **ONLY** those adapters and attachments provided and approved by the manufacturer.
- When extension bars and/or offset attachments are used, the rated capacity is always **reduced by 50%** for each bar or offset attachment connected.
- **DO NOT** overextend the ram or exceed the warning line (7) on the ram's piston.
- **DO NOT** exceed the rated capacity.
- **DO NOT** adjust the safety valve (4).

5. Identification and Unpacking

5.2 What's in the Box?

Carefully remove the product from the packaging and examine it for any signs of damage that may have occurred during shipment.

Before assembling the product, lay the contents out and check them against the parts shown below. If any part is damaged or missing, do not attempt to use the product. Please contact the Draper Helpline; contact details can be found at the back of this manual.

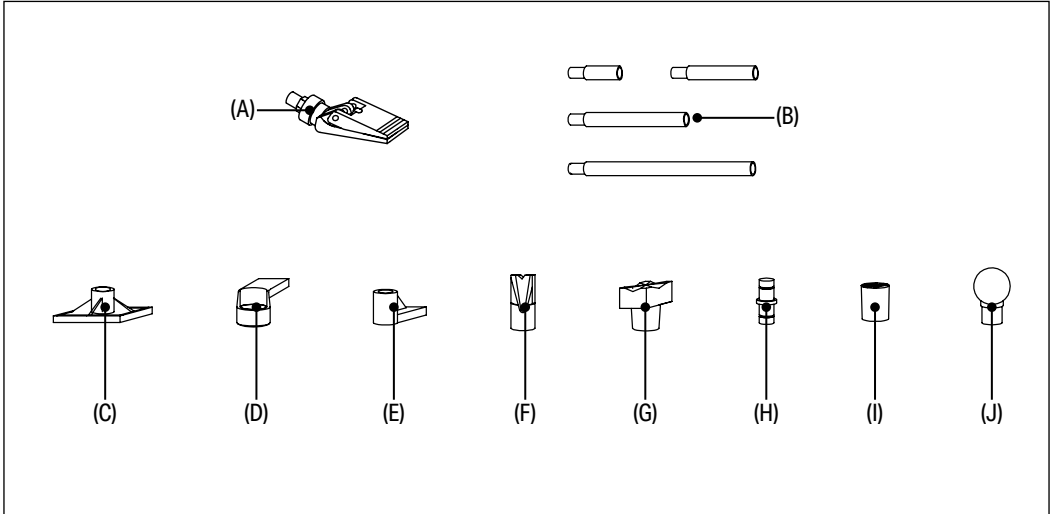

(A) Spreader

(B) Extension Bars
13590 (4 Tonnes) X 5
13930 (10 Tonnes) X 4

(C) Flat Base

(D) Ram Toe

(E) Plunger Toe

(F) Wedge Head

(G) 90° V Base

(H) Male Connector

(I) Serrated Saddle

(J) Rubber Head

5.3 Packaging

Keep the product packaging for the duration of the warranty period for reference should the product need to be returned for repair.

WARNING! Keep packaging materials out of reach of children. Dispose of packaging correctly and responsibly and in accordance with local regulations.

Please visit drapertools.com for our full range of accessories and consumables.

6. Operating Instructions

6.1 Ram attachments

- The **extensions** (B) connect in different combinations to reach desired lengths.
- The **male connector** (H) is used to connect the female end of the ram (9) to base (C) or (G).
- The **flat base** (C) is typically used on the stationary side of the ram (9) to spread out the force of the ram.
- The **90° V base** (G) is used to offset the force of the ram (9) when there is not a straight line between the stationary side and the damaged side, or to spread out force on curved surfaces.
- The **serrated saddle** (I) is typically used on the pushing end to prevent slipping.
- The **rubber head** (J) is typically used for popping dents out of sheet metal such as doors or body panels and to minimise damage to the work surface.
- The **wedge head** (F) is used to repair small dents and areas located in angles and tight spaces.
- The **ram toe** (D) and **plunger toe** (E) are used together to allow spreading in areas that the ram cannot fit into.

Note: The ram toe and plunger toe must be used together to prevent an off-centre load.

6.2 Spreader Set Up - Fig. 1

The spreader (A) is used when the ram (9) is too long to fit between the stationary side and the damaged area.

1. Clean the end of the hose (6) and the inlet on the spreader (A).
2. Unscrew and save the dust covers located on the end of the hose (6) and spreader (A).
3. Attach the hose (6) to the spreader (A).

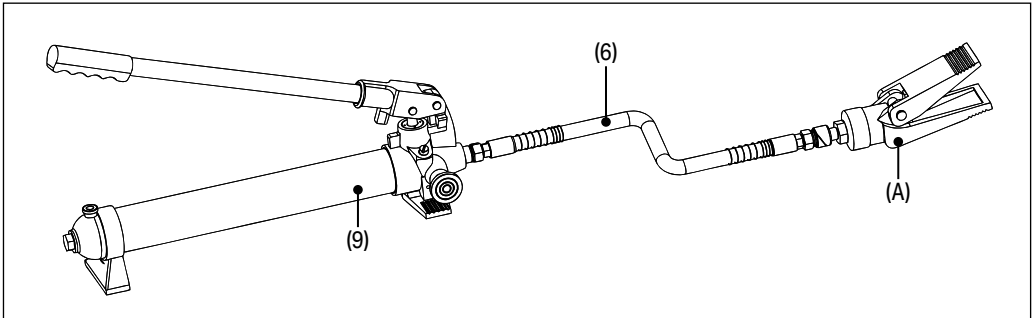

Fig. 1

6.3 Ram Set Up - Fig. 2

When extension tubes and/or offset attachments are used, the rated capacity is always reduced by 50% for each tube or offset attachment connected.

1. Clean the end of the hose coupler (8) and the inlet on the ram (9).
2. Unscrew and save the dust covers located on the end of the hose coupler (8) and ram (9).
3. Attach the hose to the ram.
4. Assemble attachments as shown in Fig 2.

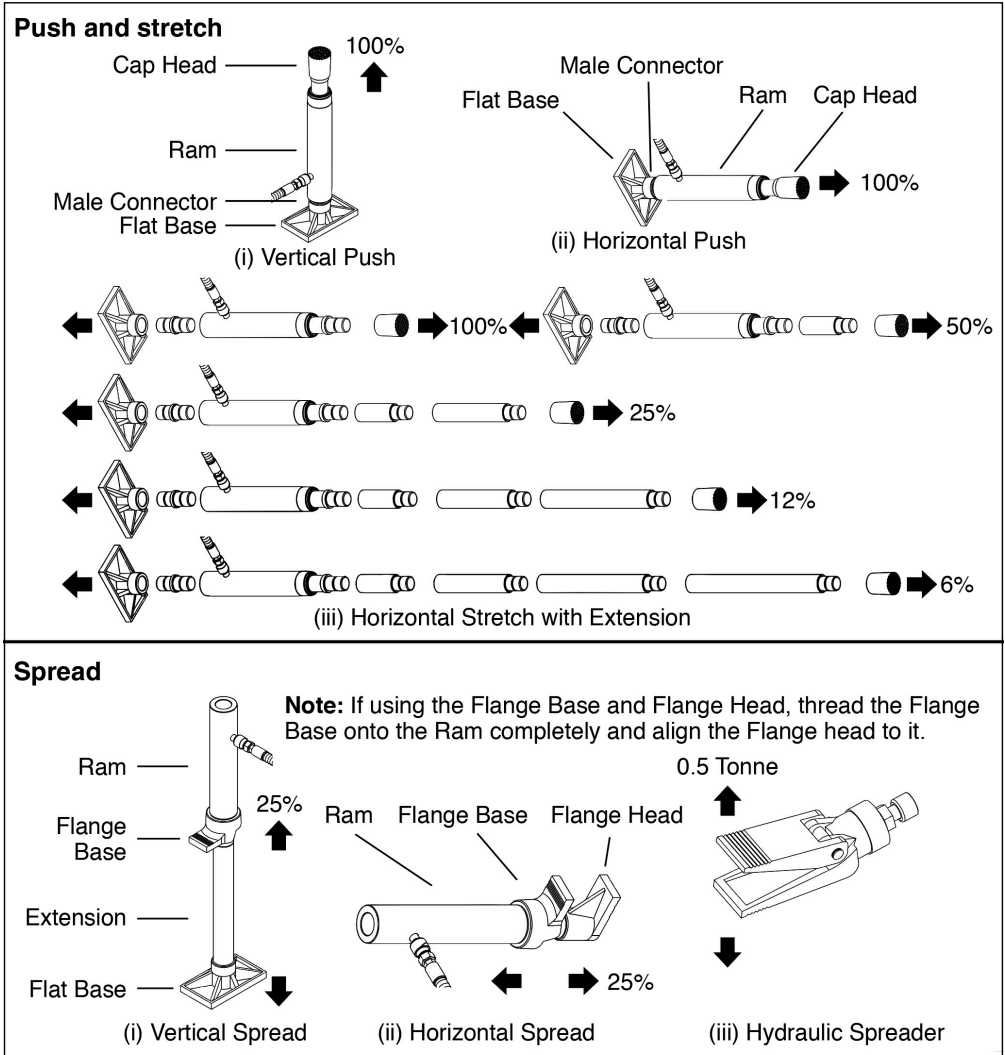

Fig. 2

6. Operating Instructions

6.4 To operate the pump - Fig. 3 & 4

1. Always check the hydraulic fluid level before using, following the instructions in the Maintenance section.
2. Determine which direction the frame needs to be bent.
3. Remove any obstructions that could be damaged or are in the way.
4. Position the pump unit on a stable, flat and level surface.
5. Close the release valve (5) by turning it clockwise until it is firmly closed. Pump the handle to apply pressure.

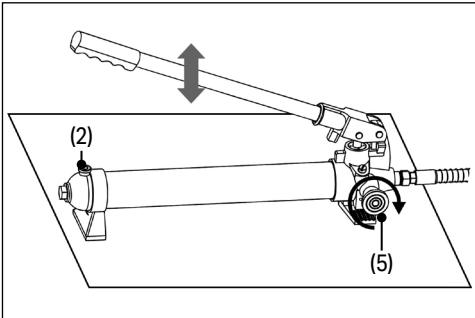

Fig. 3

6. Turn the release valve (5) counter-clockwise to release the pressure.

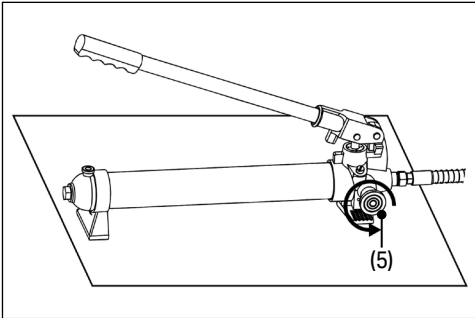

Fig. 4

Note: The pump unit may be positioned horizontally or vertically. When using the hydraulic pump (3) in a vertical position, always keep the hose (6) end of the hydraulic unit downwards.

6.5 To operate the ram

1. Connect the appropriate base (C), (D) or (G) to the stationary side of the ram (9) and connect the appropriate head to the pushing end of the ram.
Note: When repairing larger body panel dents such as a dented door, fender or quarter-panel use the rubber head (J) on the pushing end.
2. If using the flat base (C) or ram toe (D): Remove the protection cap (11). Then thread the flat base onto the ram completely and align the ram toe to it. The flat base and ram toe must be used together to prevent an off-centre load.
3. Position the ram (9) so that the base is resting against a frame member opposite the damaged area. It must also be in line with the direction in which the damaged area needs to be pushed. The vehicle body part must be stronger than the area to be bent or it may be damaged. A block of wood or a towel may be used to protect the body part.
4. Aim the pushing end towards the area that needs to be repaired and slowly apply pressure with the pump (3).

Note: To prevent damage, do not overextend the ram.

6.6 To operate the spreader

1. Place the spreader (A) so that the hinged (pushing) arm is resting against the part to be moved and the stationary arm is resting against a non-movable base.
2. Carefully hold the spreader in position and apply pressure with the pump (3).

⚠ Warning!

- Once both ends have made contact, move as far away as possible and continue to slowly apply pressure to the damaged area until the desired bend has been made.
- **CAUTION! Keep hands away from contact areas and tight spaces. The tool may slip and cause injury.**
- When the damaged area has been bent to the desired position, slowly turn the release valve (5) counter-clockwise to release the hydraulic pressure and remove the ram (9) or spreader (A).
- Clean all hydraulic ports and cover them with clean dust covers to prevent contamination and damage.

7.1 Cleaning and Maintenance

- Keep the surface of this tool and its accessories free of hydraulic fluid and grease. Use only a mild detergent and damp cloth when cleaning. Do not use a flammable or combustible solvent to clean this tool or its accessories.
- Before each use, examine the general condition of the tool and its accessories. Check for loose components, misalignment, binding of moving parts, broken parts and any other condition that may affect its safe operation. Do not use a damaged tool or its damaged accessories.
- Grease the handle socket regularly.
- Keep hydraulic connections clean. Clean all hydraulic ports and replace dust covers immediately after use.
- Store the pump (3) with the release valve (5) open.

7.2 Filling and Bleeding Hydraulic Fluid

If the pump (3) operation feels spongy, or the ram (9) lowers while the release valve (5) is closed there may be air in the pump. Check and bleed the pump as follows:

- **Checking Fluid Level**
 - Place the pump (3) on a flat level surface and firmly close the release valve (5).
 - Remove the filler screw (2). The seal ring should remain fitted. The fluid level should be near the bottom of the opening. If required, add high grade hydraulic fluid.
 - Ensure the seal ring is still fitted to the filler screw and refit the filler screw securely to the pump. Do not use thread seal tape.
- **Bleeding air from Pump**
 - Place the pump (3) on a flat level surface and open the release valve (5) by 1½ – 2 turns. Loosen the filler screw slightly.
 - Pump the handle 10 – 15 times to remove any air.
 - Close the release valve (5) and tighten the filler screw (2).
- **Changing hydraulic fluid**
 - Change the hydraulic fluid yearly.
 - Remove the filler screw (2) and tilt the pump (3) to drain out the old fluid.
 - Refill the hydraulic fluid and refit the filler screw (2).
 - Bleed the system several times to ensure all air is out of the system.

7. Maintenance and Troubleshooting

7.3 Troubleshooting

Problem	Possible Cause	Remedy
Ram does not operate when handle is pumped.	Release valve not tightly closed.	Firmly close the release valve.
	Air in the pump. The steel ball is immersed inside for too long a time.	See 7.2 Filling and Bleeding Hydraulic Fluid. Please follow these steps: <ol style="list-style-type: none">1. Open the release valve by 1½ – 2 turns, pump up the handle 10 – 15 times.2. Close the release valve by turning it clockwise, pump up the handle 10 – 15 times.3. Repeat steps 1 and 2 about 3 times. Contact the Draper Helpline for assistance
Ram will not hold load.	Release valve not tightly closed.	Firmly close the release valve.
	Malfunction in pump such as dirt inside valve mechanism.	Please follow these steps: <ol style="list-style-type: none">1. Open the release valve by 1½ – 2 turns, pump up the handle 10 – 15 times.2. Close the release valve by turning it clockwise, pump up the handle 10 – 15 times.3. Repeat steps 1 and 2.
Ram reluctant to lower when load removed.	Oil reservoir overfilled.	Drain oil to correct level.
	Piston binding.	Clean and lubricate moving parts.
	Ram overextended.	Replace Ram.
Ram will not extend to full range of stroke.	Low oil level.	Add hydraulic oil to the reservoir.
Ram tries to tilt to one side.	Incorrect use of connection or unbalanced footing.	Stop work and reposition ram and base, ensuring it is well supported and as close to perpendicular to the repair as possible.

8. Spares, Returns and Disposal

For spare parts, servicing, and repair and replacement options, please contact the Draper Tools Product Helpline for details of your nearest authorised agent.

Draper Tools will endeavour to hold any spare parts, if applicable, for seven years from the date that it sells the final matching stock item.

Any servicing or repairs carried out by unauthorised personnel or installation of spare parts not supplied by Draper Tools will invalidate your warranty.

Important: For safety, **ALWAYS** drain and clean the product of any oil, fuel, chemicals or other substances before returning it to Draper Tools or its authorised agent. Store these materials in suitable containers and dispose of them in accordance with local regulations. Draper Tools and its agents cannot be responsible for the disposal of these substances.

At the end of its working life, dispose of the product responsibly and in line with local regulations. Recycle where possible.

- **DO NOT** dispose of this product with domestic waste; most local authorities provide appropriate recycling facilities.
- **DO NOT** incinerate.
- During decommissioning of the equipment, certain hazards should be understood and avoided: Only with the line pressure released shall the equipment be disassembled. Goggles should be worn.
- Dispose of oil separately and in accordance with local regulations; **DO NOT** abandon it in the environment.



9. Warranty

Draper Tools products are carefully tested and inspected before shipment and are guaranteed to be free from defective materials and workmanship.

Should the tool develop a fault, return the complete tool to your nearest distributor or contact Draper Tools directly. Contact information can be found at the back of this manual.

Proof of purchase must be provided.

If, upon inspection, it is found that the fault occurring is due to defective materials or workmanship, repairs will be carried out free of charge. This warranty period covers parts and labour for 12 months from the date of purchase. Where tools have been hired out, the warranty period covers 90 days from the date of purchase.

This warranty does not apply to any consumable parts, batteries or normal wear and tear, nor does it cover any damage caused by misuse, careless or unsafe handling, alterations, accidents, or repairs attempted or made by any personnel other than the authorised Draper Tools repair agent.

In all cases, to make a claim for faulty workmanship or materials within the standard warranty period, please contact or return the product to the place of purchase. Proof of purchase may be required.

If the place of purchase is no longer trading or if you experience any difficulties with your warranty, please contact Customer Services with the product details and your proof of purchase. Contact details can be found at the back of this manual.

If the tool is not covered by the terms of this warranty, repairs and carriage charges will be quoted and charged accordingly.

This warranty supersedes any other guarantees expressed or implied and variations of its terms are not authorised.

Your Draper Tools guarantee is not effective until you can produce, upon request, a dated receipt or invoice to verify your purchase within the guarantee period.

Please note that this warranty is an additional benefit and does not affect your statutory rights.

Draper Tools Limited

Contact Details

Draper Tools

Draper Tools Limited
Hursley Road
Chandler's Ford
Eastleigh
Hampshire
SO53 1YF
UK

Website: drapertools.com

Email: sales@drapertools.com

Product Helpline: +44 (0) 23 8049 4344

Telephone Sales Desk: +44 (0) 23 8049 4333

General Enquiries: +44 (0) 23 8026 6355

Delta International

Delta International BV
Oude Graaf 8
6002 NL
Weert
Netherlands

Please contact the Draper Tools Product Helpline for repair and servicing enquiries.