

**EN**

Original Instructions

Version 1

**DRAPER**<sup>®</sup>  
*Expert*

750L/MIN 7HP PETROL

# TRASH WATER PUMP

16128



UK  
CA **CE**

# 1. Preface

These are the original product instructions. This document is part of the product; retain it for the life of the product, passing it on to subsequent holders. Read this manual in full before attempting to assemble, operate, or maintain this product.

This Draper Tools manual describes the purpose of the product and contains all the necessary information to ensure its correct and safe use. Following all the instructions and guidance in this manual will ensure the safety of both the product and the operator and increase the lifespan of the product.

All photographs and drawings within this manual are supplied by Draper Tools to help illustrate correct operation of the product.

Every effort has been made to ensure the information contained in this manual is accurate. However, Draper Tools reserves the right to amend this document without prior warning. Always use the latest version of the product manual.

## 1.1 Product Reference

**User Manual for:** 750L/Min 7HP Petrol Trash Water Pump

**Stock No:** 16128

**Part No:** PWP82T

## 1.2 Revisions

**Version 1:** May 2016  
First release

**Version 2:** June 2022  
General format and content revisions

As our manuals are continually updated, always ensure that the latest version is used.

**Download the latest version from:**  
[drapertools.com/manuals](http://drapertools.com/manuals)

## 1.3 Understanding the Safety Content



**WARNING!** – Situations or actions that may result in personal injury or death.

### ATTENTION

Situations or actions that may result in damage to the product or surroundings.

**Important** – Information or instructions of particular importance.

## 1.4 Copyright © Notice

Copyright © Draper Tools Limited.

Permission is granted to reproduce this manual for personal and educational use **ONLY**. Commercial copying, redistribution, hiring, or lending is strictly prohibited.

No part of this manual may be stored in a retrieval system or transmitted in any other form or means without written permission from Draper Tools Limited.

In all cases, this copyright notice must remain intact.

1. Preface	2	10.6 Changing the Engine Oil	17
1.1 Product Reference	2	10.7 Draining the Fuel	18
1.2 Revisions	2	10.8 Storing the Pump	19
1.3 Understanding the Safety Content	2	10.9 Periodic Maintenance	20
1.4 Copyright © Notice	2	11. Optional Accessories	21
2. Contents	3	11.1 Risk of Fire	21
3. Warranty	4	11.2 Risk of Injury and Property Damage When Transporting Water Pump	22
4. Product Introduction	5	11.3 Risk of Breathing – Inhalation Hazard	22
4.1 Scope	5	11.4 Risk of Unsafe Operation	22
4.2 Specification	5	11.5 Risk of Hot Surfaces	23
5. Health and Safety Information	6	11.6 Risk of Moving Parts	23
5.1 General Safety Instructions	6	11.7 Risk from Lifting	23
5.2 Additional Health and Safety Instructions for this Trash Water Pump	6	12. Optional Accessories	24
5.3 Health and Safety Information for Machines with a Petrol Engine	7	12.1 Draper Suction Hoses	24
6. Identification and Unpacking	8	12.2 Draper Hose Clamps	24
6.1 Product Overview	8	13. Troubleshooting	25
6.2 What's in the Box?	9	14. Disposal	26
6.3 Packaging	9	15. Explanation of Symbols	27
7. Preparing the Water Pump	10		
7.1 Hose Connection	10		
8. Setting the Water Pump	11		
8.1 Checking the Engine Oil	11		
8.2 Fuelling	12		
9. Basic Water Pump Operation	13		
9.1 Priming the Pump	13		
9.2 Starting the Pump	13		
9.3 Stopping the Pump	14		
10. Maintenance and Storage	15		
10.1 General Maintenance	15		
10.2 Cleaning out Blockages	15		
10.3 Changing the Oil	16		
10.4 Changing the Air Filter Element	16		
10.5 Spark Plug Care	17		

### 3. Warranty

---

Draper Tools products are carefully tested and inspected before shipment and are guaranteed to be free from defective materials and workmanship.

Should the tool develop a fault, return the complete tool to your nearest distributor or contact Draper Tools directly. Contact information can be found at the back of this manual.

Proof of purchase must be provided.

If, upon inspection, it is found that the fault occurring is due to defective materials or workmanship, repairs will be carried out free of charge. This warranty period covers parts and labour for 12 months from the date of purchase. Where tools have been hired out, the warranty period covers 90 days from the date of purchase.

This warranty does not apply to any consumable parts, batteries or normal wear and tear, nor does it cover any damage caused by misuse, careless or unsafe handling, alterations, accidents, or repairs attempted or made by any personnel other than the authorised Draper Tools repair agent.

In all cases, to make a claim for faulty workmanship or materials within the standard warranty period, please contact or return the product to the place of purchase. Proof of purchase may be required.

If the place of purchase is no longer trading or if you experience any difficulties with your warranty, please contact Customer Services with the product details and your proof of purchase. Contact details can be found at the back of this manual.

If the tool is not covered by the terms of this warranty, repairs and carriage charges will be quoted and charged accordingly.

This warranty supersedes any other guarantees expressed or implied and variations of its terms are not authorised.

Your Draper Tools guarantee is not effective until you can produce, upon request, a dated receipt or invoice to verify your purchase within the guarantee period.

Please note that this warranty is an additional benefit and does not affect your statutory rights.

#### **Draper Tools Limited**

## 4.1 Scope

This product is designed for the transfer of wastewater that contains solid and semi-solid substances and debris in environments in which access to mains power is limited. It is intended for trade use, with the quality and features necessary to meet and exceed the expectations of the most demanding user. Any other application beyond the conditions established for use will be considered misuse. Draper Tools accepts no responsibility for improper use of this product.



**WARNING! This product is not a toy and must be respected.**

Read this manual in full before attempting to assemble, operate or maintain the product, and retain it for later use.

## 4.2 Specification

Stock No.	16128
Part No.	PWP82T
Engine	7hp 4 stroke
Suction aperture	75mm (3")
Output aperture	75mm (3")
Displacement	196cc
Max. flow	750L/min
Max. head height	26m
Max. suction head height	7m
Noise emissions:	
Sound pressure level	92dB(A)
Sound power level	108dB(A)
Fuel capacity	3.6L
Dimensions	W 570 x H 450 x D 460mm
Application	Dirty water
Net weight	35kg

**Important:** Read all the Health and Safety instructions before attempting to operate, maintain or repair this product. Non-compliance with these instructions may result in injury or damage to the user or the product.

## 5.1 General Health and Safety Instructions

- **ONLY** trained persons familiar with the Health and Safety information and use of this product may operate the pump.
  - **DO NOT** allow children or persons who are not trained in the use of this product to operate it.
- Observe all standard safety precautions and good practices when in a workshop environment.
- Allow adequate space for the pump and hoses during use.
- Keep your work environment clear and well-lit, with bystanders at a safe distance.
- Use the product only in the manner instructed in this manual.
- **DO NOT** use this product while tired or under the influence of alcohol, drugs, or other medication.
- **DO NOT** modify this product in any way.
- **ONLY** use spare parts supplied by Draper Tools.
- Check the product for broken, worn, or loose parts before every use.



**WARNING! DO NOT use the product if any part of the machine is damaged. Have it repaired immediately by approved and suitably qualified personnel.**

- Keep your hands, face, other body parts and loose clothing away from moving parts when the pump is in use.
- **NEVER** leave this machine running unattended.
  - **ALWAYS** switch the machine off and allow it to cool before walking away.
- **ALWAYS** ensure that the pump has been switched off, cooled and has completely stopped before moving or maintaining the product.
  - After use, **ALWAYS** allow at least 30 minutes for the pump to cool before moving or maintaining the product.
  - **ALWAYS** disconnect and drain the suction and discharge hoses before moving or maintaining the product.

- Maintain and clean the tool frequently and thoroughly to ensure a long lifespan for the product.
- This product must be repaired **ONLY** by suitably qualified personnel authorised to do so by Draper Tools.

## 5.2 Additional Health and Safety Instructions for this Trash Water Pump

### ATTENTION

**This product is NOT shipped with engine oil. ALWAYS check and top up the engine oil before every use.**

- Use this product **ONLY** on firm, level surfaces.
- **DO NOT** expose this machine to water or wet environments.
  - **ONLY** the connected hoses and internal pumping system should come into contact with liquids.
- **NEVER** use the pump if the stop switch is faulty, unusable, or missing.
- Ensure that the suction and discharge hoses are laid out flat and safely.
- **NEVER** operate the pump without first correctly priming it.

### ATTENTION

**NEVER operate the pump without water passing through it.**

- **ALWAYS** wear ear defenders while working near this machine.
- **NEVER** obstruct the discharge outlet or hose as this may severely damage the product.
- **NEVER** allow the pump or its contents to freeze.
- **NEVER** use this product to pump corrosive or toxic materials.
- **DO NOT** cover or obstruct any ventilation points or grilles.
- **NEVER** stand or step on the pump or frame.
- **DO NOT** attempt to move the pump by pulling on or lifting the hosing.
  - Carry the pump **ONLY** by the metal frame.
  - The pump is heavy; use any appropriate lifting equipment to move the pump and ask for assistance if required.

- **DO NOT** drop or strike the pump.
    - If sudden force is applied to the pump, **IMMEDIATELY** switch it off and inspect it for damage.
-  **WARNING! DO NOT continue to use the pump if it has sustained any damage.**
- During transportation, keep the pump well ventilated and out of direct sunlight and other sources of heat or ignition.
    - If the journey is likely to be uneven or bumpy, ensure that the pump has been drained before it is moved.

### 5.3 Health and Safety Information for Machines with a Petrol Engine

-  **WARNING! Petrol is highly flammable and petrol vapour is explosive. Take extreme caution when handling petrol and keep it out of reach of children.**

**DO NOT operate this machinery in any hazardous location that present a risk of explosion from petrol fumes, gas leakage or explosive dust.**

- **ALWAYS** refuel the machine outdoors.
- **DO NOT** expose the pump to direct sunlight for prolonged periods.
- **ALWAYS** securely fasten the fuel cap before use.
- **NEVER** smoke in the vicinity of the machine, especially during refuelling.
- **NEVER** start the engine if you can smell petrol vapour in the air.
  - If petrol vapour is present, wait for it to dissipate or move to a new location.
- **ALWAYS** add fuel before starting the engine, **NEVER** while the engine is running.

-  **WARNING! The engine and fuel get hot during use. The exhaust system may become hot enough to ignite some materials.**
- **DO NOT** touch the engine during or immediately after use and allow it to cool before refuelling.
  - Keep the pump away from flammable substances during use and until cooled.

- **NEVER** remove the fuel cap while the engine is running or immediately after use.
  - Take care when opening the fuel cap after use as hot vapour may be released from the opening.
- **NEVER** place objects on the engine while it is in use and keep all air vents clear of dust, dirt and other obstructions.
- **DO NOT** attempt to start the machine engine near spilled petrol
  - Allow vapours from spilled fuel to dissipate before starting.
  - Spilled fuel may be ignited by the engine.
- To reduce the risk of fire, keep the engine, silencer and petrol storage area free of vegetative material and excessive grease.
- **ONLY** drain the machine of fuel and oil in a well-ventilated outdoor environment.
- Allow the engine to cool before storing the machine.
- **NEVER** store the machine with fuel in the tank in an environment where fumes may reach an open flame or spark.
- Store fuel in containers that are specifically designed to do so
- **DO NOT** operate the machine in confined spaces in which carbon monoxide fumes from the exhaust may accumulate.

-  **WARNING! The machine exhaust emits toxic carbon monoxide: a colourless and odourless gas. Breathing exhaust fumes can cause loss of consciousness, permanent respiratory damage and eventually death. ONLY operate this machine in a well-ventilated outdoor environment.**

## 6.1 Product Overview

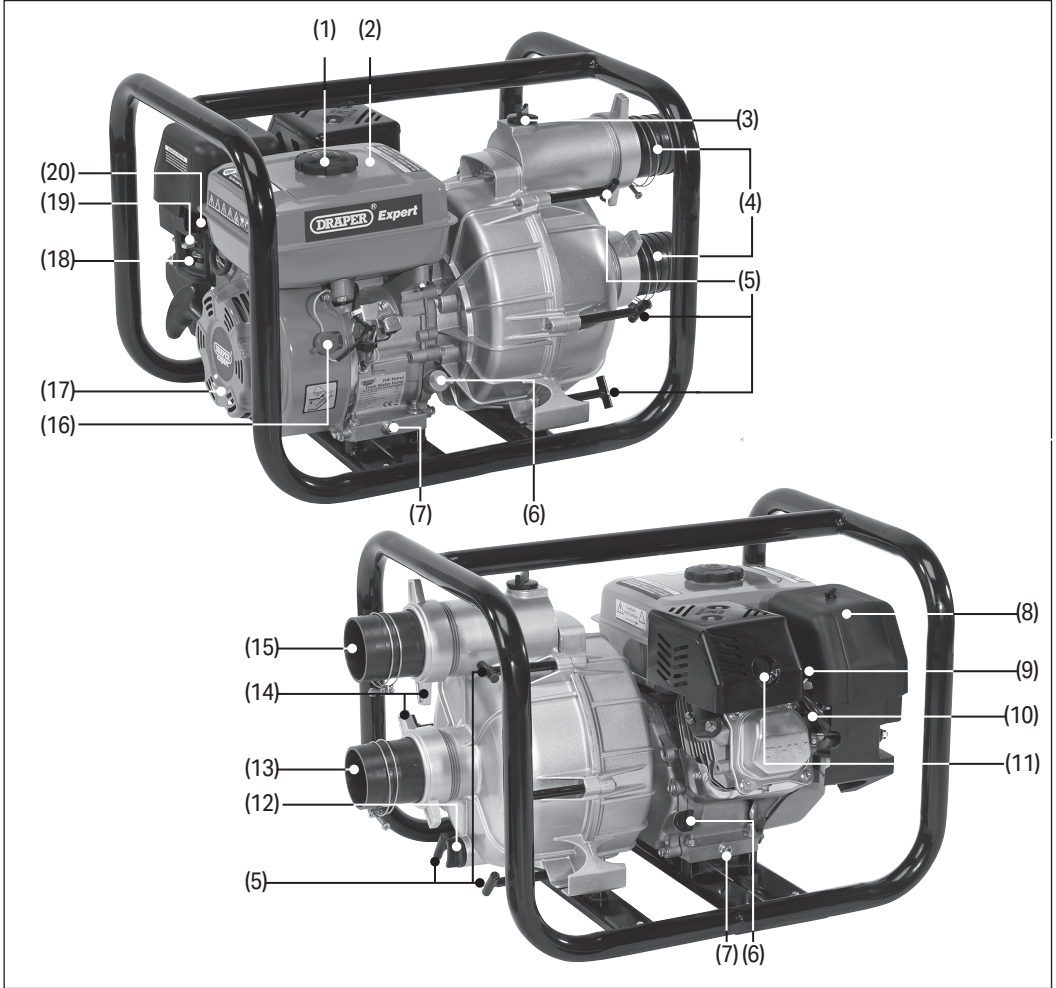

- |                        |                                 |
|------------------------|---------------------------------|
| (1) Fuel tank cap      | (11) Muffler (exhaust)          |
| (2) Fuel tank          | (12) Water drain                |
| (3) Priming cap        | (13) Inlet (suction)            |
| (4) Hose barb          | (14) Hose barb coupling         |
| (5) "T" bolts          | (15) Outlet                     |
| (6) Oil level dipstick | (16) Main engine switch         |
| (7) Oil drain plug     | (17) Recoil (pull) start handle |
| (8) Air filter housing | (18) Fuel lever                 |
| (9) Spark plug cap     | (19) Choke lever                |
| (10) HT lead           | (20) Throttle lever             |



# 6. Identification and Unpacking

## 6.2 What's in the Box?

Carefully remove the water pump from the packaging and examine it for any signs of damage that may have occurred during shipment.

Before assembling the product, lay the contents out and check them against the parts shown below. If any part is damaged or missing, do not attempt to use the product. Please contact the Draper Helpline; contact details can be found at the back of this manual.

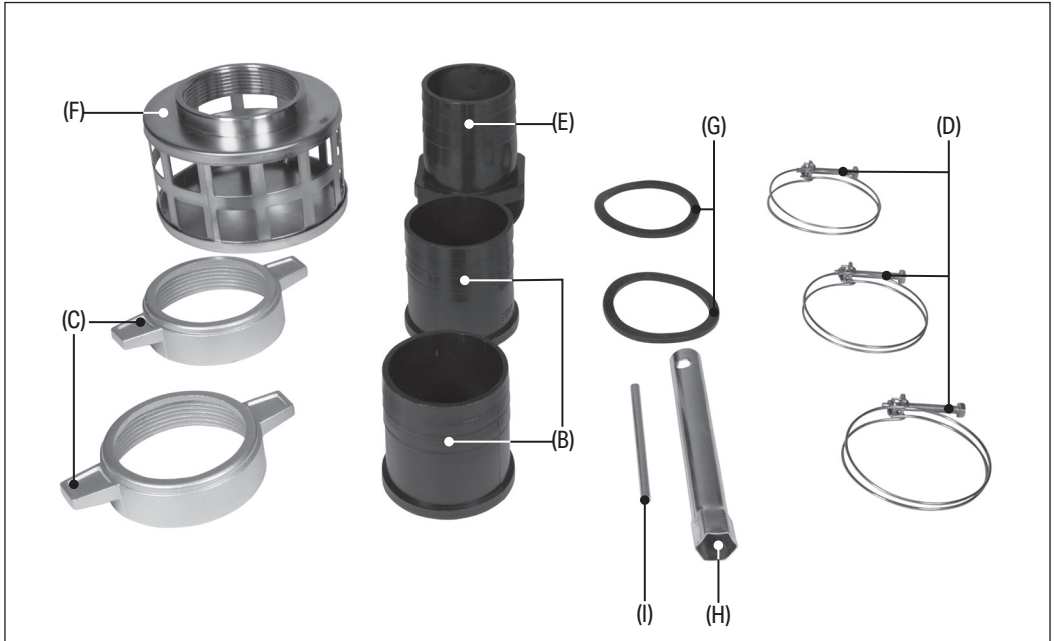

- (A) 1 x Pump unit (not shown)
- (B) 2 x Hose barbs
- (C) 2 x Hose barb couplings
- (D) 3 x Hose clamps
- (E) 1 x Filter barb

- (F) 1 x Strain filter
- (G) 2 x O-ring seals
- (H) 1 x Spark plug spanner body
- (I) 1 x Spark plug spanner handle

## 6.3 Packaging

Keep the product packaging for the duration of the warranty period for reference should the product need to be returned for repair.

**WARNING!** Keep packaging materials out of reach of children. Dispose of packaging correctly and responsibly and in accordance with local regulations.

Please visit [drapertools.com](http://drapertools.com) for our full range of accessories and consumables.

# 7. Preparing the Water Pump

## 7.1 Hose Connection

Use a solid wall (reinforced) hose to stop the hose from collapsing on the suction side of the pump. Please see the optional accessories section for recommended suction hose.

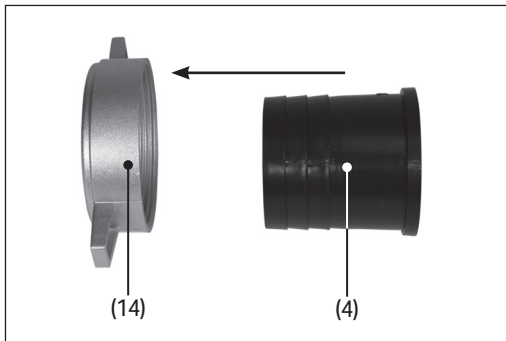

Fig. 1

1. Pass the hose barb (4) through the threaded side of the hose barb coupling (14) so that the thread sits away from the hose barb (Fig. 1).
2. Place an O-ring seal (G) inside the hose bar coupling so that it rests against the hose barb.

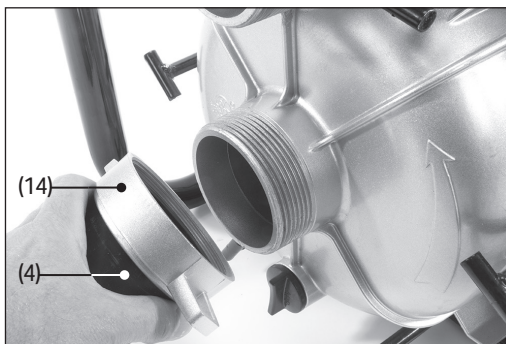

Fig. 2

3. Screw the hose barb assembly onto the pump inlet (13) (Fig. 2).

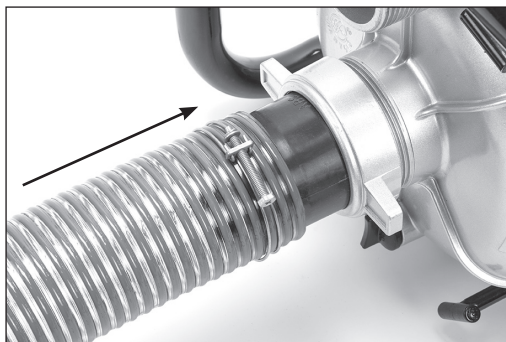

Fig. 3

4. Slide a hose clamp (D) over one end of the solid wall hose (not supplied) and push that end of the hose as far as possible onto the hose barb (Fig. 3).
5. Move the hose clamp so that it sits centrally on the covered hose barb and twist the clamp screw clockwise until tight to secure the hose in place.

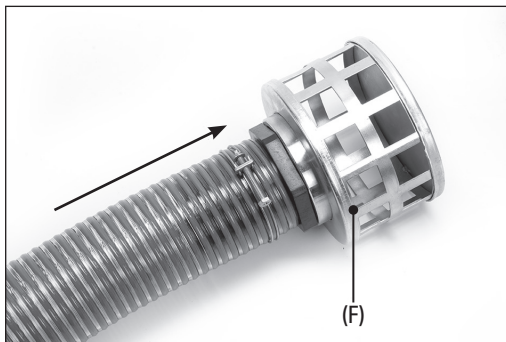

Fig. 4

6. Screw the filter barb (E) into the strain filter (F) (Fig. 4).
7. Slide a hose clamp onto the other end of the hose and push the hose onto the filter barb as far as possible.
8. Place the hose clamp centrally on the filter barb and twist the clamp screw clockwise until tight.

Repeat steps 1–5 for the discharge hose (not supplied) if required. Connect the discharge hose to the pump outlet (15).

## 8. Setting the Water Pump

### 8.1 Checking the Engine Oil

#### ATTENTION

This product is **NOT** shipped with engine oil. **ALWAYS** add oil before first use.

**Important:** Ensure that the oil reservoir is filled with **SAE30 four-stroke oil** before starting the motor. Damage to the motor is **NOT** covered under warranty if the motor is run without oil.

1. Before checking or refilling the oil, ensure that the pump is switched off, cool and is positioned on a stable and level surface.
2. Remove the oil filter cap (6) by rotating the cap anticlockwise.

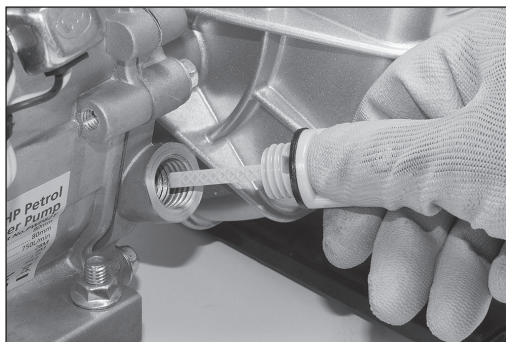

Fig. 6

6. If the oil is contaminated or has discoloured, ensure you change the oil; see section 10.1 (Fig. 6).

This motor is fitted with a low oil sensor and will stop operating or will not start if the oil level is too low. Check the oil level each time the pump is used.

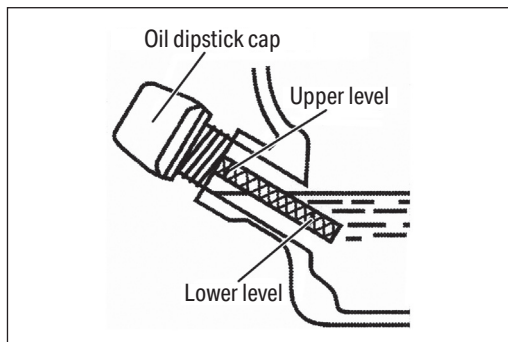

Fig. 5

3. Wipe the dipstick clean and re-insert it into the oil reservoir (Fig. 5).
4. Remove the dipstick from the reservoir again and inspect the oil level against the high and low markers.

**Important: DO NOT** screw the dipstick back into the reservoir when checking the oil level, simply insert it and pull it out.

5. If the oil level is below the lower line, refill it until the upper line is reached.

## 8.2 Fuelling

Use unleaded petrol **ONLY**.

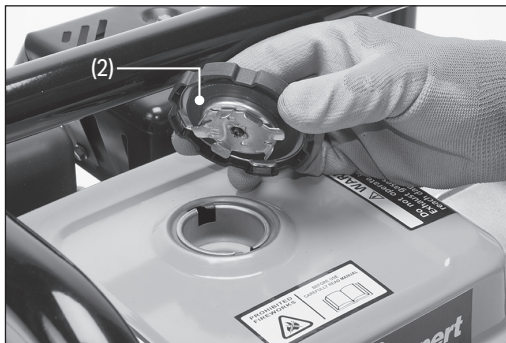

Fig. 7

1. Remove the petrol cap (2) (Fig. 7).

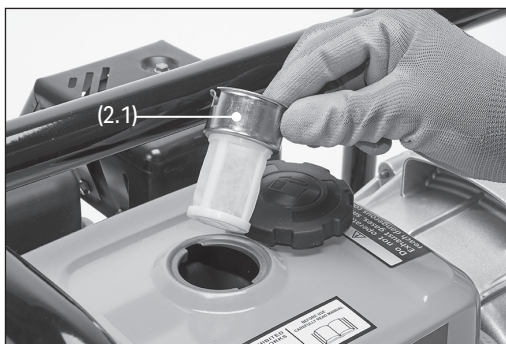

Fig. 8



Fig. 9

2. Check that the fuel filter (2.1) is in place and pour the fuel into the tank (Figs. 8–9).

### ATTENTION

**DO NOT overfill the tank. Leave an air gap between the fuel and the roof of the tank.**

3. Screw down the fuel cap securely and clean up any spilled fuel immediately.

**WARNING!** **DO NOT** start the engine in the presence of spilled petrol or petrol vapour as sparks may cause it to ignite.

4. Move the water pump at least 4m (12ft) away from the fuelling area before starting.

### WARNING!

- Do not refill the fuel tank while the engine is running or is hot.
- Check to ensure that the petrol cap has been tightened and that fuel is not leaking.
- Be careful not to admit dust, dirt, water or other foreign objects into the fuel.
- Wipe off spilt fuel thoroughly before starting the engine.
- Ensure you **do not** fuel the pump in close proximity to any open flames.

**Important:** Place the pump on a firm and level surface during use. Keep in mind that the length of the hoses and the difference in elevation between the pump and the source and delivery reservoirs may impact the flow rate.

**ATTENTION**

**This pump is NOT shipped with engine oil. ALWAYS add engine oil to the product before first use.**

## 9.1 Priming the Pump

**ATTENTION**

**NEVER use the pump without first priming it.**

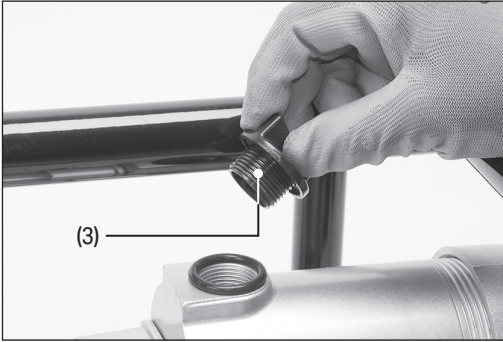

Fig. 10

1. Remove the priming cap (3) and fill the pump housing with water before refitting the cap and starting your pump (Fig. 10).

This will allow the pump to create a low-pressure vacuum that will draw the water up for pumping.

2. Fill the suction hose up with water.

**Important:** Ensure that the strain filter (F) is fitted to the suction hose and remains completely submerged throughout the pumping operation.

**Important:** Once your pump is started, it may take several minutes to complete priming. This time will vary due to the length of the suction hose fitted (a longer suction hose will take longer to fully prime and start pumping water).

Once the pump has fully primed, it will draw the water from the water source and pump it out through the pump's outlet and into any layflat discharge hose that is fitted to direct the pumped water to the desired location.

## 9.2 Starting the Pump

**Important:** Read and understand all Health and Safety guidance and preparation instructions before attempting to operate the pump.

1. Slide the fuel lever (18) to the right to turn on the fuel supply.
2. Slide the throttle lever (20) to the left to open the throttle slightly.

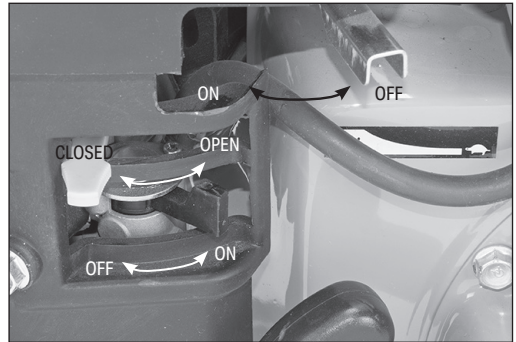
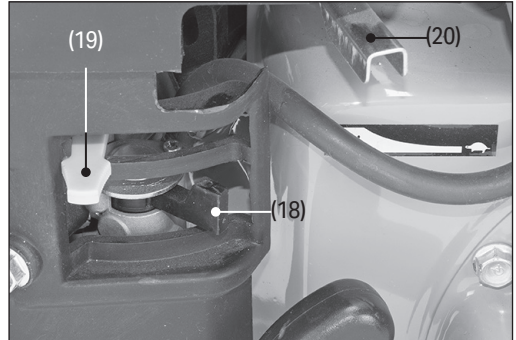

Fig. 11

3. Open or close the choke as appropriate (Fig. 11):
  - When performing a cold start, keep the choke closed (pushed to the right).
  - When performing a warm start, open the choke (pushed to the left) while starting the engine.

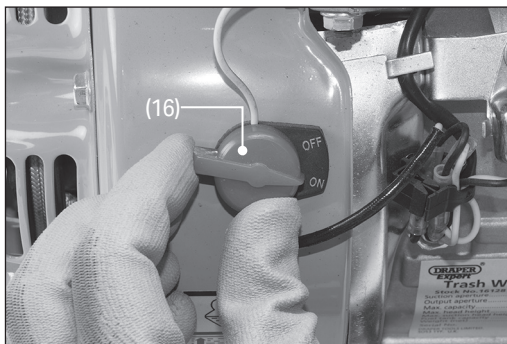

Fig. 12

4. Turn the engine switch (16) to the ON position (Fig. 12).

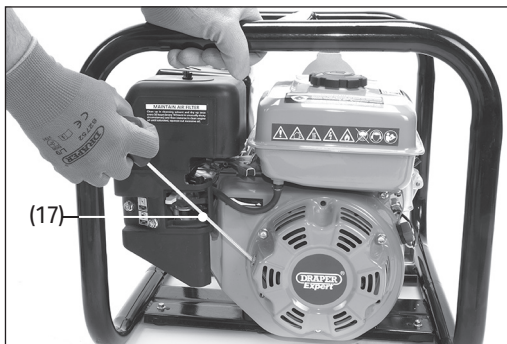

Fig. 13

5. Gently pull on the recoil starter (17) until resistance is felt, then pause and pull it out rapidly (Fig. 13).

### ATTENTION

**DO NOT** attempt to start the engine when the recoil starter is full retracted. **DO NOT** allow the recoil starter to snap back against the engine. Return it gently to prevent damage to the starter.

6. Allow the engine to run for a few minutes and warm up.
7. Close the choke so that the engine runs smoothly (Fig. 14), then increase the throttle speed to begin pumping.

**Important:** Lower the throttle to idle (pushed to the right) or switch off the engine whenever the pump is not in use.

## 9.3 Stopping the Pump

**Important:** Before stopping the engine, lower the throttle to idle (pushed to the left) and run the engine for a few minutes.

- If the engine is only being stopped for a moment, slide the fuel lever to the left and turn the engine switch (16) off.
- If the engine is being stopped and later stored, slide the fuel lever to the left and wait for the engine to cut out before turning the engine switch (16) to the OFF position.
- In the event of an emergency, immediately turn the engine switch (16) to the OFF position.

**Important: ALWAYS** drain the product of **BOTH FUEL AND OIL** before returning it to Draper Tools for repairs.

**Important:** This product may only be serviced by qualified and authorised personnel.

**⚠ WARNING! DO NOT attempt to perform any maintenance on this product unless the engine is switched off and has cooled.**

This water pump has been designed to operate over a long period of time.

Continuous satisfactory operation depends upon proper machine care, regular cleaning and following the periodic maintenance schedule. If the pump is operating in unusually dusty or hot conditions, the time between servicing the pump must be decreased.

## 10.1 General Maintenance

- **ONLY** use spare parts supplied by Draper Tools.
- Inspect the pump and any attached pipes for damage, blockage or loose fixings and attachments before each use.
  - Clean any dirty, dusty or blocked parts.
  - Tighten all loose bolts or fixings.
  - Replace any broken or worn parts before use.

**⚠ WARNING! DO NOT use this product if any part is broken or damaged.**

- Clean the pump with a damp cloth **ONLY**.

**Important: DO NOT** use solvents as this may damage the plastic parts of the product.

- Protect the pump and its components from adverse environmental and weather conditions, both during use and when stored.
  - **DO NOT** use the pump in the rain or in wet surroundings.
- Keep all air vents clean and free from obstructions at all times.

## 10.2 Cleaning out Blockages

**ALWAYS** ensure that the water pump is turned off before attempting to open the pump.

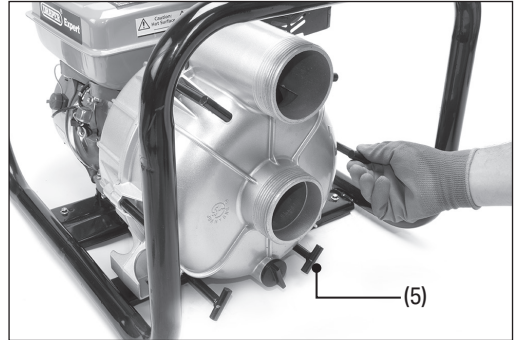

Fig. 14

1. To open the pump, twist the six "T" handles anticlockwise and pull the cover away from the pump (Fig. 14).
2. Clean inside the housing and around the impeller.



Fig. 15

3. Remove and clean the impeller (Fig. 15).
4. Reattach the impeller and reassemble the housing.

**Important:** After the blockage has been removed, the pump must be primed again before use.

## 10.3 Changing the Oil

**Important:** The engine oil should be changed after the first 20 hours of operation and then every 100 hours thereafter.

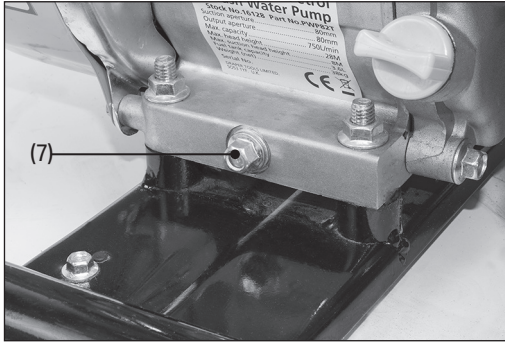

Fig. 16

1. Unscrew and remove the dipstick, followed by the sump bolt (7). Catch the used oil in a suitable container and dispose of it in an approved manner (Fig. 16).
2. When all the oil has drained from the engine block, replace the sump bolt and refill the engine oil up to the maximum level.
3. Use oil grade SAE10W-30 or equivalent.

## 10.4 Changing the Air Filter Element

**Important:** The air filter element should be replaced after every 50 hours of operation.

**ATTENTION**

**DO NOT** start the engine if the air filter element is not installed.

1. Unscrew the wingnut and remove the air filter housing (11).

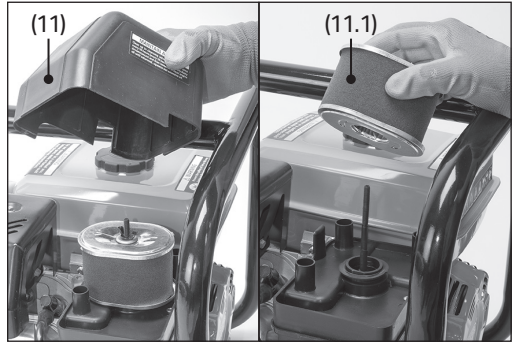

Fig. 17

2. Remove and clean the filter element (11.1) in warm soapy water or a high-flashpoint solvent and allow it to dry completely (Fig. 17).
3. When the filter element is dry, soak it in engine oil.
4. Squeeze the excess oil from the element before refitting it and replacing the air filter housing.



## 10.5 Spark Plug Care

**Important:** The spark plug should be checked and cleaned after every 50 hours of use and replaced if necessary.

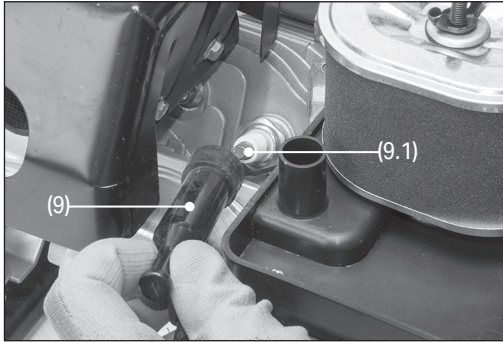

Fig. 18

1. Remove the spark plug cap (9) by hand (Fig. 18).

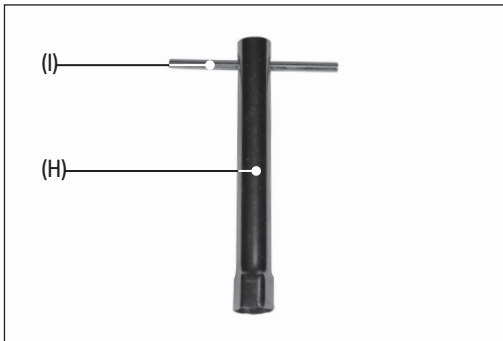

Fig. 19

2. Pass the spark plug spanner handle (I) through the holes in the spark plug spanner body (H) and use the assembled spanner to remove the spark plug (Fig. 19).
3. Inspect and clean the spark plug:
  - a. The spark plug should be tan in colour.
  - b. Check the spark plug for cracks or chips in the ceramic insulator.
  - c. Measure the gap using a feeler gauge (not supplied) and correct it as appropriate by gently bending the electrode into position.  
**Important:** The gap should be **0.7–0.8mm**.
  - d. Replace the spark plug if necessary.
4. Install the spark plug using 20Nm of torque.

## 10.6 Changing the Engine Oil

**Important:** The engine oil should be changed after the first 20 hours of operation and then every 100 hours thereafter.

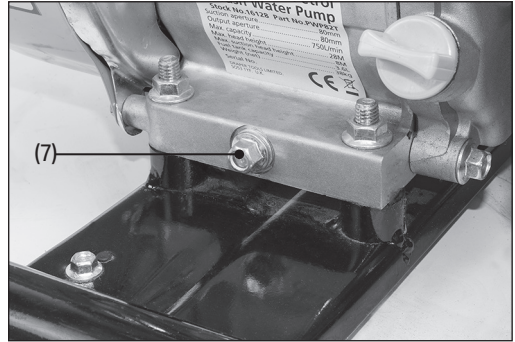

Fig. 20

1. Unscrew and remove the dipstick (6), then the sump bolt (7) and drain the oil into a suitable container. (Fig. 20).
2. When all the oil has drained from the engine block, replace the sump bolt and refill the engine oil up to the maximum level.

**Important:** ALWAYS dispose of oil in accordance with local regulations.

**Important:** Use oil grade SAE10W-30 or equivalent.

## 10.7 Draining the Fuel

**Important:** Read all the Health and Safety guidance for the use of petrol as a fuel before filling or using this product.

1. Ensure that the fuel lever (18), throttle lever (20), choke lever (19) and engine switch (16) are in their OFF or lowest positions and allow the engine to cool for at least 30 minutes (see Fig. 14).
2. Unscrew the fuel tank cap (1) and remove the fuel filter.



Fig. 21

3. Use a siphon to empty the fuel tank into a suitable petrol container (Fig. 21).
4. Reinstall the fuel filter and fuel tank cap securely.

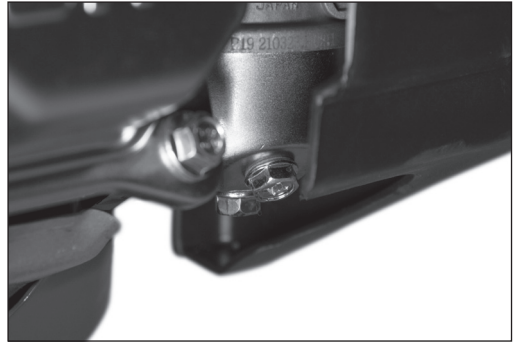

Fig. 22

5. Loosen the carburettor drain screw and drain the carburettor into a suitable container (Fig. 22).
6. Gently pull the recoil start handle (17) until resistance is felt, then pull it firmly.  
  
Do this four times to empty the fuel pump of petrol into a suitable container.
7. Tighten the carburettor drain screw.

## 10.8 Storing the Pump

Prepare the pump correctly if it is to be stored for a prolonged period:

1. Ensure that all switches are in the OFF or lowest position.
2. **ALWAYS** allow the pump to cool for at least 30 minutes when storing it after use.
3. Remove, drain and dry the suction and discharge hoses and clean around the inlet and outlet openings.  
Ensure all other water is also drained from the pump.
4. Drain the fuel from the engine before storage (see **10.5 Draining the Fuel**).
5. Drain the engine oil (see **10.3 Changing the Engine Oil**).
6. Cover the pump with a plastic sheet to protect it against dust and moisture.

Observe the following points when storing the pump:

- Store the pump in a dry and dust-free environment, out of reach of children.
- Store the pump in its operating position.
  - **NEVER** store the pump on its side as this may cause fuel or oil to leak and damage the pump or the surrounding property.
  - Where possible, secure the pump in its upright position to prevent it from tipping over while unattended.
- Prepare and run the engine at periodic intervals to prevent seizure within the engine and driveshaft.

## 10.9 Periodic Maintenance

Item	Remarks	Pre-operation check (daily)	Initial 1 month or 20hrs	Every 3 months or 50hrs	Every 6 months or 100hrs	Every 12 months or 300hrs
Spark plug	Check condition, adjust gap and clean. Replace if necessary.			•		
Engine oil	Check oil level.	•				
	Replace.		•		•	
Air filter	Clean. Replace if necessary.			•		
Fuel filter	Clean fuel drain filter. Replace if necessary.				•	
Valve clearance	Check and adjust when engine is cold.					•
Fuel line	Check fuel hose for cracks or damage. Replace if necessary.	•				
Exhaust system	Check for leakage. Retighten or replace gasket if necessary.	•				
	Check muffler screen. Clean/replace if necessary.				•	
Carburettor	Check choke operation.	•				
Starting system	Check key start ignition operation.	•				
Decarbonisation	More frequently if necessary.					•
Fittings/fasteners	Check all fittings and fasteners correct if necessary.				•	

Regular maintenance is most important for the best performance and safe operation. For guidance relating to any of the listed procedures, contact the Draper Helpline; details can be found on the back page of this manual.

# 11. Associated Risks and Preventative Measures

## 11.1 Risk of Fire

Hazard	What could happen	How to prevent it
Attempting to fill the fuel tank while the engine is running	Fuel and fuel vapours can become ignited by coming in contact with hot components such as the muffler, engine exhaust gases, or an electrical spark.	Turn the engine off and allow it to cool before adding fuel to the tank. Equip the area of operation with a fire extinguisher certified to handle gasoline or fuel fires.
Sparks, fire, hot objects	Cigarettes, sparks, fires or other hot objects can cause fuel or fuel vapours to ignite.	Add fuel to the tank in a well-ventilated area. Make sure there are no ignition sources near the water pump.
Improper storage of fuel	Improperly stored fuel could lead to accidental ignition. Fuel improperly secured could get into the hands of children or other unqualified persons.	Store fuel in an approved container designed to hold fuel. Store the container in a secure location to prevent use by others.
Tampering with factory set engine speed settings	The engine speed has been factory set to provide safe operation. Tampering with the engine speed adjustment could result in overheating of attachments and could cause a fire.	Never attempt to speed-up the engine to obtain more performance. Both the output voltage and frequency will be thrown out of standard by this practice, endangering attachments and the user.
Inadequate ventilation for water pump	Placing materials against or near the water pump or operating it in areas where the ambient temperature exceeds 40°C (such as storage rooms or garages) can interfere with its proper ventilation features, causing overheating and possible ignition of the materials or buildings.	Operate water pump in a clean, dry, well-ventilated area. <b>Do not operate unit indoors or in any confined area.</b>
Overfilling the fuel tank – fuel spillage	Spilled fuel and its vapours can become ignited from hot surfaces or sparks.	Use care in filling the tank to avoid spilling fuel. Make sure fuel cap is secured tightly and check engine for fuel leaks before starting engine. Move water pump away from refuelling area or any spillage before starting engine. Allow for fuel expansion. Never refuel with the engine running.

# 11. Associated Risks and Preventative Measures

## 11.2 Risk of Injury and Property Damage When Transporting Water Pump

Hazard	What could happen	How to prevent it
Fire, inhalation, damage to vehicle surfaces	Fuel or oil can leak or spill, resulting in fire, a breathing hazard, serious injury or death. Fuel or oil leaks can damage carpet, paint or other surfaces in vehicles or trailers.	The water pump is equipped with a fuel drain valve; turn the valve to the off position before transporting to avoid fuel leaks. Transport fuel in an approved fuel container. When transporting, always place the water pump on a protective mat to protect against damage from leaks. Remove the water pump from the vehicle immediately upon arrival at your destination.

## 11.3 Risk of Breathing – Inhalation Hazard

Hazard	What could happen	How to prevent it
Gasoline engines produce toxic carbon monoxide exhaust fumes	Breathing exhaust fumes will cause serious injury or death.	Operate the water pump in a clean, dry, well-ventilated area.  Never operate unit in enclosed areas such as garages, basements, storage, sheds or in any location occupied by humans or animals. Keep children, pets and others away from area of operating unit.

## 11.4 Risk of Unsafe Operation

Hazard	What could happen	How to prevent it
Careless operation of water pump	All sources of energy include the potential for injury. Unsafe operation or maintenance of your water pump could lead to serious injury or death to you or others.	Review and understand all of the operating instructions and warnings in this manual.  Become familiar with the operation and controls of the water pump. Know how to shut it off quickly.  Equip the area of operation with a fire extinguisher certified to handle gasoline or fuel fires.  Keep children or others away from the water pump at all times.
Operating water pump while suspended	The water pump will not operate properly and will be damaged and could cause serious injury or death to you or others.	Never operate water pump while suspended or in an unlevel position. Always operate on a flat, level surface.

# 11. Associated Risks and Preventative Measures

## 11.5 Risk of Hot Surfaces

Hazard	What could happen	How to prevent it
Contact with hot engine and water pump components	Contact with hot surfaces, such as engine exhaust components, could result in serious burns.	During operation, touch only the control surfaces of the water pump. Keep children away from the water pump at all times. They may not be able to recognise the hazards of this product.

## 11.6 Risk of Moving Parts

Hazard	What could happen	How to prevent it
Contact with moving parts can result in serious injury	The water pump contains parts that rotate at high speed during operation. These parts are covered by guarding to prevent injury.	Never operate the water pump with guarding or cover plates removed. Avoid wearing loose-fitting clothing or jewellery which could be caught by moving parts.

## 11.7 Risk from Lifting

Hazard	What could happen	How to prevent it
Lifting a very heavy object	Serious injury can result from attempting to lift too heavy an object.	When lifting, always keep the object you are lifting near the vertical axis of your body. <b>Do not</b> use your back to lift heavy loads. Both people should crouch down, grab the underside of the unit and use their legs to carry the weight. Keep the object as near the centre of your body's gravity as possible. Avoid twisting your body when carrying the unit; instead, turn your whole body using your feet.

## 12. Optional Accessories

### 12.1 Draper Suction Hoses

Description	Stock No.	Part No.
3" Suction hose	20471	APWP3

### 12.2 Draper Hose Clamps

Description	Stock No.	Part No.
3" Hose clamps (x 2)	22601	SHC3



Problem	Possible cause	Remedy
The engine does not start.	The fuel level is too low.	Check the fuel level and top it up if it is low (see <b>8.2 Fuelling</b> ).
	The fuel lever is in the lowest position.	Move the fuel lever to a higher position and attempt to start the engine.
	There is no spark from the spark plug.	Remove and check the spark plug (see <b>10.5 Spark Plug Care</b> ).
	The cause is not listed or cannot be identified.	Contact an authorised service agent for repair and replacement options.
The pump fails during use.	The priming water level is low.	Check the pump housing water level and top it up if it is low (see <b>9.1 Priming the Pump</b> ).
	The strainers are clogged.	Remove the strainers from the suction and discharge hoses and clean them if they are blocked.
	The hoses are not airtight.	Ensure that the hose clamps are securely fastened and check the hoses and seals for damage and splits.
	The suction hose is blocked.	Check that the end of the suction hose is not submerged in mud or sediment and ensure that the hose is not bent or crushed.
	The impeller is blocked or damaged.	Clean or replace the impeller (see <b>10.2</b> ).
	The cause is not listed or cannot be identified.	Contact an authorised service agent for repair and replacement options.

# 14. Disposal

At the end of its working life, or when it can no longer be repaired, dispose of the product according to local regulations.

Contact your local authority for details of collection schemes in your area.

In all circumstances:

- **DO NOT** dispose of this product with domestic waste
- **DO NOT** dispose of this product with unsorted municipal waste
- **DO NOT** incinerate
- **DO NOT** abandon in the environment
- **ALWAYS** drain the product of fuel and oil before disposal
  - Dispose of fuel and oil responsibly and in accordance with local regulations



# 15. Explanation of Symbols



Do not expose to rain or wet conditions



**WARNING!**



Danger!  
Highly flammable liquid



Wear ear defenders



Read the instruction manual



Hot surfaces, do not touch



**CAUTION!**  
Risk of electric shock



WEEE –

Waste Electrical & Electronic Equipment

Do not dispose of Waste Electrical & Electronic Equipment in with domestic rubbish



Do not abandon in the environment



Keep away from sources of heat



Sound power level



Top up oil to the level indicated

## Contact Details

### **Draper Tools**

Draper Tools Limited

Hursley Road

Chandler's Ford

Eastleigh

Hampshire

SO53 1YF

UK

**Website:** [drapertools.com](http://drapertools.com)

**Email:** [sales@drapertools.com](mailto:sales@drapertools.com)

**Product Helpline:** +44 (0) 23 8049 4344

**Telephone Sales Desk:** +44 (0) 23 8049 4333

**General Enquiries:** +44 (0) 23 8026 6355

**General Fax:** +44 (0) 23 8026 0784

### **Delta International**

Delta International BV

Oude Graaf 8

6002 NL

Weert

Netherlands

### **Service / Warranty Repair Agents**

For aftersales servicing or warranty repairs, please contact the Draper Tools Product Helpline for details of an agent in your area.