

DRAPER[®]

SELF PROPELLED PETROL

LAWN MOWER

08671 & 08672



Please note that model number 08672 is illustrated throughout this instruction booklet.

UK
CA CE

These instructions accompanying the product are the original instructions. This document is part of the product, keep it for the life of the product passing it on to any subsequent holder of the product. Read all these instructions before assembling, operating or maintaining this product. This manual has been compiled by Draper Tools describing the purpose for which the product has been designed, and contains all the necessary information to ensure its correct and safe use. By following all the general safety instructions contained in this manual, it will ensure both product and operator safety, together with longer life of the product itself. All photographs and drawings in this manual are supplied by Draper Tools to help illustrate the operation of the product. Whilst every effort has been made to ensure the accuracy of information contained in this manual, the Draper Tools policy of continuous improvement determines the right to make modifications without prior warning.

1. TITLE PAGE

1.1 INTRODUCTION

USER MANUAL FOR: Self Propelled Petrol Lawn Mower

Stock Nos: 08671 & 08672

Part Nos: LMP410SP & LMP460

1.2 REVISION HISTORY

Date first published: November 2020.

Revised December 2023

January 2025

As our user manuals are continually updated, users should make sure that they use the very latest version.

Downloads are available from: <http://drapertools.com/manuals>

Draper Tools Limited
Hursley Road
Chandler's Ford
Eastleigh
Hampshire
SO53 1YF
UK

Delta International
Oude Graaf 8
6002 NL
Weert
Netherlands

Website: drapertools.com

Product help line: +44 (0) 23 8049 4344

General Fax: +44 (0) 23 8026 0784

1.3 UNDERSTANDING THIS MANUAL'S SAFETY CONTENT

WARNING! – Information that draws attention to the risk of injury or death.

CAUTION! – Information that draws attention to the risk of damage to the product or surroundings.

1.4 COPYRIGHT © NOTICE

Copyright © Draper Tools Limited.

Permission is granted to reproduce this publication for personal and educational use only. Commercial copying, redistribution, hiring or lending is prohibited.

No part of this publication may be stored in a retrieval system or transmitted in any other form or means without written permission from Draper Tools Limited.

In all cases this copyright notice must remain intact.

2. CONTENTS

2.1 CONTENTS

1. TITLE PAGE	
1.1 INTRODUCTION	2
1.2 REVISION HISTORY.....	2
1.3 UNDERSTANDING THIS MANUAL'S SAFETY CONTENT	2
1.4 COPYRIGHT © NOTICE	2
2. CONTENTS	
2.1 CONTENTS	3
3. WARRANTY	
3.1 WARRANTY.....	4
4. INTRODUCTION	
4.1 SCOPE	5
4.2 SPECIFICATION.....	5
4.3 HANDLING AND STORAGE	5
5. HEALTH AND SAFETY INFORMATION	
5.1 LAWN MOWER SAFETY WARNINGS	6
5.2 HEALTH AND SAFETY INFORMATION CONCERNING THE USE OF FUELS	8
6. TECHNICAL DESCRIPTION	
6.1 IDENTIFICATION.....	9
7. UNPACKING AND CHECKING	
7.1 PACKAGING.....	10
7.2 WHAT'S IN THE BOX.....	10
8. PREPARING THE LAWN MOWER	
8.1 ASSEMBLING THE HANDLE.....	11
8.2 ATTACHING THE CABLE CLIPS.....	11
8.3 ASSEMBLING THE GRASS COLLECTION BAG.....	12
8.4 ASSEMBLING THE GRASS COLLECTION BAG ONTO THE LAWN MOWER.....	12
8.5 FILLING WITH OIL AND CHECKING THE OIL LEVEL	13
8.6 FILLING WITH ENGINE FUEL.....	14
8.7 SETTING THE CUTTING HEIGHT	14
9. OPERATING THE LAWN MOWER	
9.1 START UP OPERATION	15
9.2 MOWING	15
10. MAINTENANCE	
10.1 MAINTENANCE.....	16-17
11. TROUBLESHOOTING	
11.1 TROUBLESHOOTING GUIDE.....	18
12. EXPLANATION OF SYMBOLS	
12.1 EXPLANATION OF SYMBOLS.....	19
13. DISPOSAL	
13.1 DISPOSAL.....	19

3. WARRANTY

3.1 WARRANTY

Draper tools have been carefully tested and inspected before shipment and are guaranteed to be free from defective materials and workmanship.

Should the tool develop a fault, please return the complete tool to your nearest distributor or contact

Draper Tools Limited, Chandler's Ford, Eastleigh, Hampshire, SO53 1YF. England.

Telephone Sales Desk: +44 (0) 23 8049 4333 or Product Help Line +44 (0) 23 8049 4344.

A proof of purchase must be provided with the tool.

If upon inspection it is found that the fault occurring is due to defective materials or workmanship, repairs will be carried out free of charge. This warranty period covering labour is 12 months from the date of purchase except where tools are hired out when the warranty period is 90 days from the date of purchase. The warranty is extended to 24 months for parts only. This warranty does not apply to any consumable parts, any type of battery or normal wear and tear, nor does it cover any damage caused by misuse, careless or unsafe handling, alterations, accidents, or repairs attempted or made by any personnel other than the authorised Draper warranty repair agent.

Note: If the tool is found not to be within the terms of warranty, repairs and carriage charges will be quoted and made accordingly.

This warranty applies in lieu of any other warranty expressed or implied and variations of its terms are not authorised.

Your Draper warranty is not effective unless you can produce upon request a dated receipt or invoice to verify your proof of purchase within the warranty period.

Please note that this warranty is an additional benefit and does not affect your statutory rights.

Draper Tools Limited.

4. INTRODUCTION

4.1 SCOPE

This petrol lawn mower has been designed for the cutting of grass lawn areas in private houses and gardens. Any other application is considered misuse.

4.2 SPECIFICATION

STOCK NOS.	08671.....	08672
PART NOS.	LMP410SP.....	LMP460
DISPLACEMENT	132CC	150CC
ENGINE HORSE POWER	3.3HP	3.6HP
DRIVE TYPE	SELF PROPELLED	SELF PROPELLED
DECK MATERIAL	STEEL	STEEL
SPEED (NO LOAD)	2800RPM	2800RPM
CUTTING WIDTH	410MMØ	460MMØ
CUTTING HEIGHTS	7: 25 – 75MM.....	7: 25 – 75MM
COLLECTION BAG CAPACITY	45L.....	55L
FUEL TANK CAPACITY (UNLEADED RON95)	0.8L	0.8L
OIL TANK CAPACITY (SAE30 / 10W-30).....	0.4L	0.4L
SOUND PRESSURE LEVEL.....	79.8±3dB(A).....	81.6±3dB(A)
SOUND POWER LEVEL	91.3±3dB(A).....	93.9±3dB(A)
SINGLE VALUE NOISE LEVEL†	96dB(A).....	96dB(A)
WEIGHT (GROSS / DRY)	23KG	31KG

†A-weighted sound pressure level in accordance to 2000/14/EC.

4.3 HANDLING AND STORAGE

- Care must be taken when handling this product.
 - Dropping this lawn mower could have an effect on its accuracy and could also result in personal injury. This product is not a toy and must be respected.
- Environmental conditions can have a detrimental effect on this product if neglected.
 - Exposure to damp air can gradually corrode components.
 - If the product is unprotected from dust and debris, components will become clogged.
 - If not cleaned and maintained correctly or regularly, the machine will not perform at its best.

5. HEALTH AND SAFETY INFORMATION

5.1 LAWN MOWER SAFETY WARNINGS

LAWN MOWERS ADDITIONAL SAFETY

Warning:

Keep bystanders away.

The engine shall be stopped before carrying out adjustment, cleaning or maintenance.

Read user instructions before operating this machine.

The lawn mower shall not be operated without either the entire grass catcher or the guard in place.

Caution: Do not touch rotating blade.

Beware of blades. Blades continue to rotate after the motor is switched off. Use ear protection as appropriate.

Never operate the mower if you are tired, ill or under the influence of alcohol, drugs or medication that may impair your vision, judgement or coordination.

The blade control handle is a safety device. Never attempt to bypass its operation. Doing so makes the safety device inoperative and may result in personal injury through contact with the rotating blade. The blade control handle must operate easily in both directions and automatically return to the disengaged position when released.

SAFE OPERATION PRACTICES FOR PEDESTRIAN-CONTROLLED ROTARY LAWN MOWERS.

1. Training.

- Read the instructions carefully. Be familiar with the controls and the proper use of the equipment.
- Never allow children or people unfamiliar with these instructions to use the lawn mower, Local regulations may restrict the age of the operator.
Never mow while people, especially children, or pets are nearby.
- Keep in mind that the operator or user is responsible for accidents or hazards occurring to other people or their property.

2. Preparation.

- While mowing, always wear substantial footwear and long trousers. Do not operate the equipment when barefoot or wearing open sandals.
- Thoroughly inspect the area where the equipment is to be used and remove all objects which can be thrown by the machine.

WARNING Petrol is highly flammable:

- store fuel in containers specifically designed for this purpose;
- refuel outdoors only and do not smoke while refuelling;
- add fuel before starting the engine. Never remove the cap of the fuel tank or add petrol while the engine is running or when the engine is hot;
- if petrol is spilled, do not attempt to start the engine but move the machine away from the area of spillage and avoid creating any source of ignition until petrol vapours have dissipated;
- replace all fuel tank and container caps securely.
- Replace faulty silencers.
- Before using, always visually inspect to see that the blades blade bolts and cutter assembly are not worn or damaged. Replace worn or damaged blades and bolts in sets to preserve balance.

5. HEALTH AND SAFETY INFORMATION

- On multi-bladed machines, take care as rotating one blade can cause other blades to rotate.

3. Operation.

- Do not operate the engine in a confined space where dangerous carbon monoxide fumes can collect.
- Mow only in daylight or in good artificial light.
- Avoid operating the equipment in wet grass, where feasible.
- Always be sure of your footing on slopes. Walk, never run.
- For wheeled rotary machines, mow across the face of slopes, never up and down.
- Exercise extreme caution when changing direction on slopes.
Do not mow excessively steep slopes.
- Use extreme caution when reversing or pulling the lawn mower towards you.
- Stop the blade(s) if the lawn mower has to be tilted for transportation when crossing surfaces other than grass, and when transporting the lawn mower to and from the area to be mowed.
- Never operate the lawn mower with defective guards, or without safety devices, for example defectors and/or grass catchers, in place.
- Do not change the engine governor settings or overspeed the engine.
- Disengage all blade and drive clutches before starting the engine.
- Start the engine or switch on the motor carefully according to instructions and with feet well away from the blade(s).
- Do not tilt the lawn mower when starting the engine or switching on the motor; except if the lawn mower has to be tilted for starting. In this case, do not tilt it more than absolutely necessary and lift only the part which is away from the operator.
- Do not start the engine when standing in front of the discharge chute.
- Do not put hands or feet near or under rotating parts. Keep clear of the discharge opening at all times.
- Never pick up or carry a lawn mower while the engine is running.
Stop the engine and disconnect the spark plug wire, make sure that all moving parts have come to a complete stop and, where a key is fitted remove the key:
 - before cleaning a blockage or unclogging chute;
 - before checking, cleaning or working on the lawn mower;
 - after striking a foreign object. Inspect the lawn mower for damage and make repairs before restarting and operating the lawn mower;
 - if lawn mower starts to vibrate abnormally (check immediately).
- Stop the engine and disconnect the spark plug wire, make sure that all moving parts have come to a complete stop and, where a key is fitted remove the key:
 - whenever you leave the lawn mower;
 - before refuelling.

5. HEALTH AND SAFETY INFORMATION

- Reduce the throttle setting during engine shut down and, if the engine is provided with a shut-off valve, turn the fuel off at the conclusion of mowing.
- Go slow when using a trailing seat.

4. Maintenance and storage.

- Keep all nuts, bolts and screws tight to be sure the equipment is in safe working condition.
- Never store the equipment with petrol in the tank inside a building where fumes can reach an open flame or spark.
- Allow the engine to cool before storing in any enclosure.
- To reduce the fire hazard, keep the engine, silencer, battery compartment and petrol compartment and petrol storage area free of grass, leaves, or excessive grease.
- Check the grass catcher frequently for wear or deterioration.
- Replace worn or damaged parts for safety.
- If the fuel tank has to be drained, this should be done outdoors.

5.2 HEALTH AND SAFETY INFORMATION CONCERNING THE USE OF FUELS

Fuels are inflammable and explosive. Reduce the risk of explosion and fire by:

- Turning off and cooling the motor down before filling the tank with fuel.
- Refrain from smoking and starting open fires when handling fuels.
- Store and mix fuels in approved and correspondingly labelled canisters.
- Store fuels in closed containers. Keeping in mind that fuels may evaporate at room temperature and collect on the floor of closed rooms (risk of explosion).
- Start the device at least nine metres away from any stored fuels or flammable liquids.

Fuels are toxic, they contain substances that have an immediate toxic effect and may cause permanent damage to your health. Take all precautionary measures to prevent your body from absorbing any of these substances:

- Refill tank and siphon fuels only outdoors or in well-ventilated rooms.
- Do not inhale fuel fumes.
- Avoid contact with eyes and skin.
- Wear gloves when transferring fuel.
- When fuel has come into contact with your clothes, change them immediately. Clean your clothes before putting them back on.
- Store fuels out of the reach of children.

When handled inappropriately, fuels may cause damage to the environment:

- Transfer fuel carefully. Fuel must never trickle into the ground or the sewage system.
- Dispose of any remaining fuel in an appropriate manner. Never dispose of fuel with regular household waste.
- Fuels may be stored only for a limited time. Purchase only such quantities that can be used up within a few months.

6. TECHNICAL DESCRIPTION

6.1 IDENTIFICATION

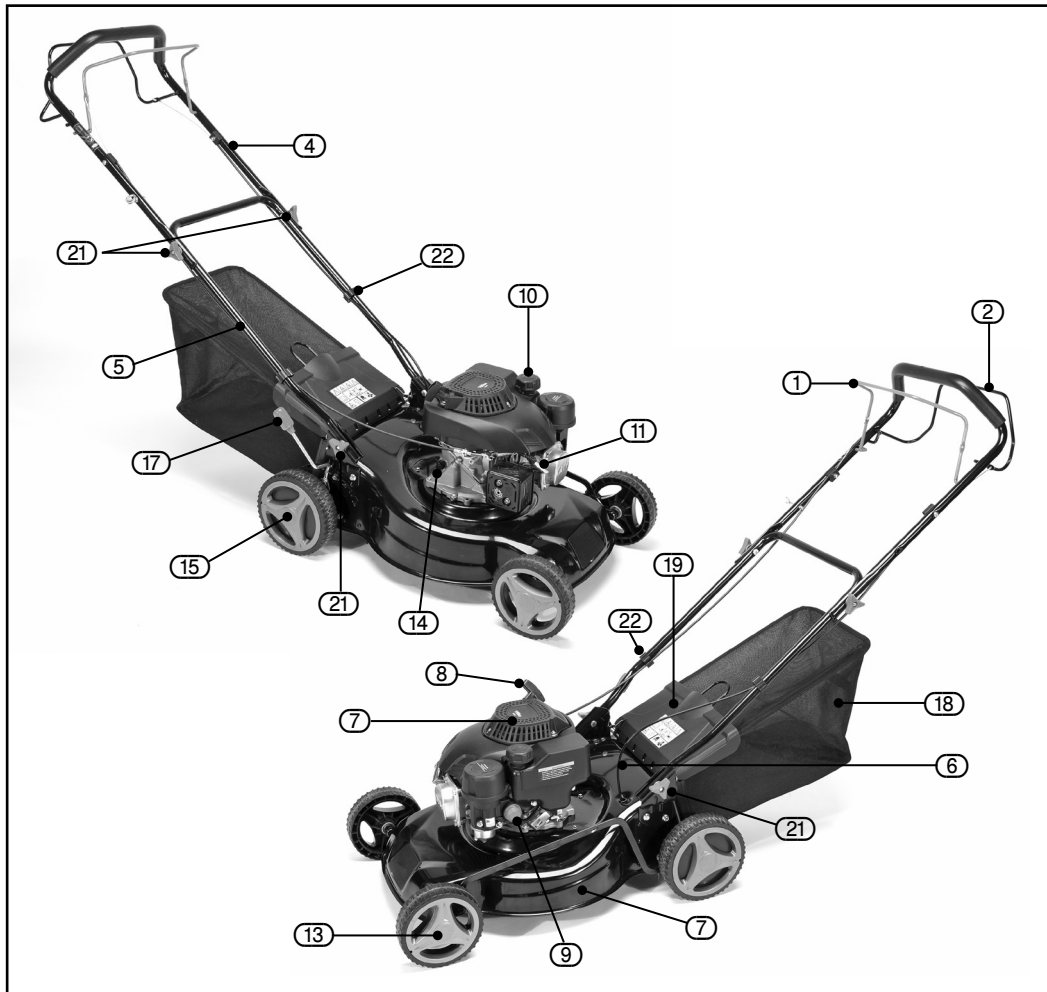

① Engine operation lever

② Drive lever

④ Upper handle section

⑤ Lower handle section

⑥ Connection cable

⑦ Main lawn mower motor/body

⑧ Starter handle

⑨ Priming bulb

⑩ Fuel tank cap

⑪ Spark plug boot

⑬ Front wheel

⑭ Engine oil cap

⑮ Rear wheel

⑯ Engine oil cap

⑰ Height adjusting handle

⑱ Grass collection bag

⑲ Rear discharge cover

⑳ Bolt and knob

㉑ Cable clips

7. UNPACKING AND CHECKING

7.1 PACKAGING

Carefully remove the product from the packaging and examine it for any sign of damage that may have happened during shipping. Lay the contents out and check them against the parts shown below. If any part is damaged or missing, please contact the Draper Help Line (the telephone number appears on the Title page) and do not attempt to use the product.

The packaging material should be retained at least during the warranty period, in case the machine needs to be returned for repair.

Warning!

- Some of the packaging materials used may be harmful to children. Do not leave any of these materials in the reach of children.
- If any of the packaging is to be thrown away, make sure they are disposed of correctly, according to local regulations.

7.2 WHAT'S IN THE BOX

As well as the lawn mower, there are several parts not fitted or attached to it.

Note: For details of our full range of accessories and consumables, please visit drapertools.com

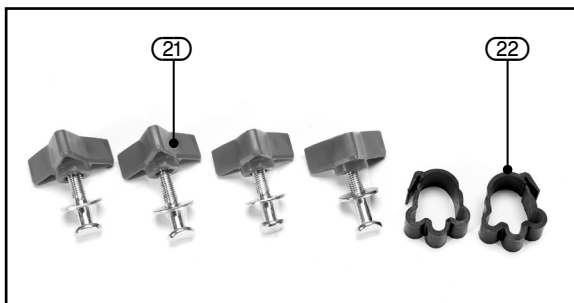

(21) 4 x bolts and knobs

(22) 2 x cable clips



8. PREPARING THE LAWN MOWER

8.1 ASSEMBLING THE HANDLE – FIGS. 1 – 4

Fasten the lower handle section (5) to the main lawn mower motor/body (7) by using two bolts and knobs (21) on each side.

Fasten the upper handle section (4) to the lower handle section (5) by using two bolts and knobs (21) on each side.

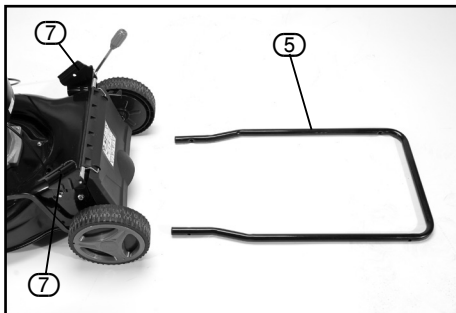

FIG. 1

8.2 ATTACHING THE CABLE CLIPS – FIG. 4

Fix the connection cable (6) to the handle with the cable clips (22).

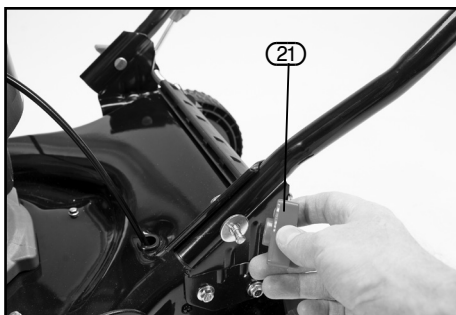

FIG. 2

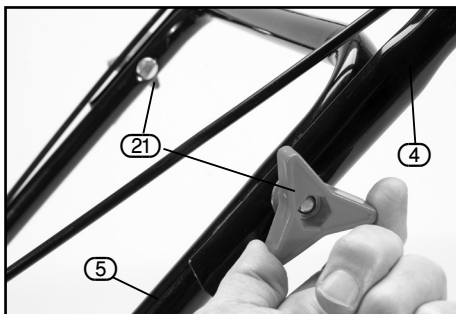

FIG. 3

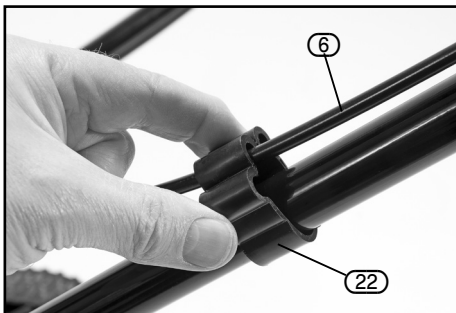

FIG. 4

8. PREPARING THE LAWN MOWER

8.3 ASSEMBLING THE GRASS COLLECTION BAG – FIGS. 7 & 8

Clip the plastic clips over the metal frame of the grass collection bag (18). Make sure that these clips are fully secured to the metal frame.

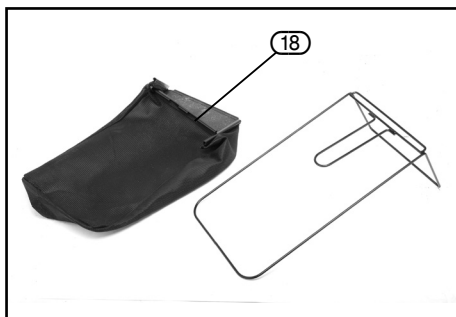

FIG. 5



FIG. 6

8.4 ASSEMBLING THE GRASS COLLECTION BAG ONTO THE LAWN MOWER – FIGS. 7 & 8

Lift the rear discharge cover (19) with one hand and hook in the grass collection bag (18). Release the rear discharge cover (19) to secure the grass bag (18) in position.

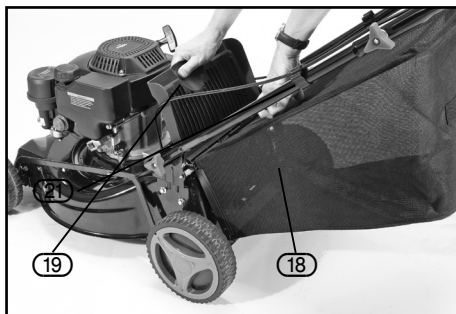

FIG. 7



FIG. 8

8. PREPARING THE LAWN MOWER

8.5 FILLING WITH OIL AND CHECKING THE OIL LEVEL – FIGS. 9 – 10

Caution!

The following procedures and adjustments must be performed before the engine is started.

Do not attempt to make any of these adjustments while the engine is running.

To prevent engine damage, the engine is shipped without oil or petrol. The engine must be filled with the correct grade of oil and petrol before starting the engine. SEE SPECIFICATION ON PAGE 5.

Note: Running the engine with a low oil level will cause engine damage. It is recommend that high detergent, premium quality 4-stroke engine oil used. Using non-detergent oil can shorten the engine's service life and using 2-stroke oil will damage the engine.

Caution!

Always use high quality detergent oil classified SAE30 oil (or equivalent e.g. SAE 10W/30, often termed as 4 Stroke lawn mower oil). Never use additives with recommended oil. To prolong the life of your engine it is important that the oil is changed after the first 5 hours of use.

Note: To check the engine oil level, stop engine and place the mower on a level surface.

Remove the engine oil cap (14) and wipe oil from it with a clean cloth. Insert the dipstick into the oil filler neck, but do not turn it in. Then remove the dipstick and check the oil level. The oil level must be between the Min and Max marks on the dipstick. If near the lower level, fill to upper lever with the recommended oil (SAE30 or equivalent). Do not overfill. Wipe away any spilt oil. Align the ribs of the cap with the groove of the filler neck, then rotate 1/4 turn to secure it.

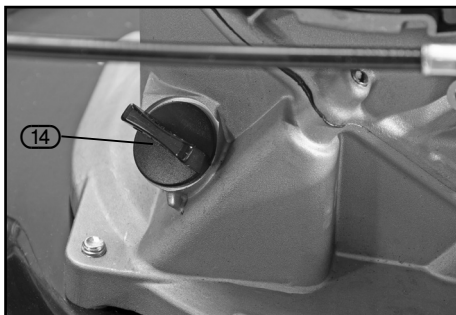

FIG. 9



FIG. 10

8. PREPARING THE LAWN MOWER

8.6 FILLING WITH ENGINE FUEL – FIG. 11

Warning!

Petrol is highly flammable and extreme precaution must be taken when handling or working with it. Keep out of reach of children. Refuel in a well-ventilated area with the engine stopped. Do not smoke or allow flame or sparks in the area where the engine is re-fueled or where petrol is stored. Avoid repeated or prolonged contact with skin or inhalation of vapour. Take extra care when filling a hot engine. Avoid if possible, and wait for the engine to cool before filling.

Caution!

Always use clean, fresh unleaded petrol (RON95). Purchase fuel in quantities that can be used within 30 days. Never mix oil with petrol. Do not fill into the base of neck to allow for fuel expansion. Do not overfill the fuel tank. To prevent engine damage the engine is shipped without oil or petrol. The engine must be filled with the correct grade of oil and petrol before starting the engine.

Clean the area around the fuel tank cap (10) before removing it. Remove the warning tag, check the fuel level. Refill the tank if the fuel level is low. Refuel carefully to avoid overfilling or spilling fuel. There should be no fuel in the filler neck. Clean up any overflow or splashes of petrol before starting the engine. Tighten the filler cap after filling, finger tight on.

8.7 SETTING THE CUTTING HEIGHT – FIG. 12

Caution!

Adjust the cutting height only when the engine is switched off the spark plug boot has been pulled.

The cutting height is centrally adjusted with the height adjusting handle (17). Different cutting heights can be selected from position 1 to position 7. The cutting height range is from 25mm to 75mm.

Pull the adjusting handle out and select the desired cutting height. The handle snaps into the desired position.



FIG. 11

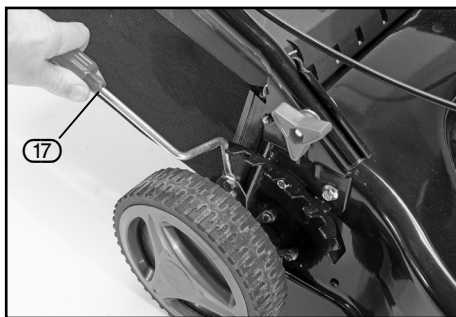

FIG. 12

9. OPERATING THE LAWN MOWER

9.1 START UP OPERATION – FIGS. 13 - 15

Firstly, check the machine and add fuel and lubricating oil.

Push the priming bulb (9) fully 2 – 3 times. Take the pull cord starter and maintain it against the upper handle. To start engine only the engine operation lever (1) needs to be closed, pull on the recoil starter handle (8) until you can feel resistance and then pull harshly.

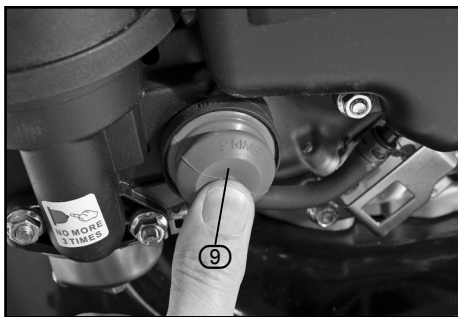

FIG. 13

9.2 MOWING

Warning!

Never open the rear flap when the grass collection bag has been detached (to be emptied) and the engine is still running. The rotating blade can cause serious injuries!

Never run with the mower and take care when mowing uneven or rough ground. Mow across slopes, never up and down. Be careful when changing the direction of the mower on a slope. Do not mow excessively steep slopes. The best result will be achieved if the grass is dry. Wet grass will tend to clog the blade and the grass collection system.

Grass grows at different rates at different time of the year. Never use the lowest cutting height for the first cut of the season or in drought conditions. Only about one third of the grass height should be cut.

When mowing with mulching, to ensure that the cut grass can be scattered efficiently, do not cut high or wet grass. When you have been cutting for several minutes, stop the mower, and clean the blade and the deck.

For both models, press the drive lever (2), the clutch will close and the lawn mower will start to move with the engine running. To stop the moving lawn mower, simply release the drive lever (2) in plenty of time. To stop the engine from running, simply release the engine operation lever (1).

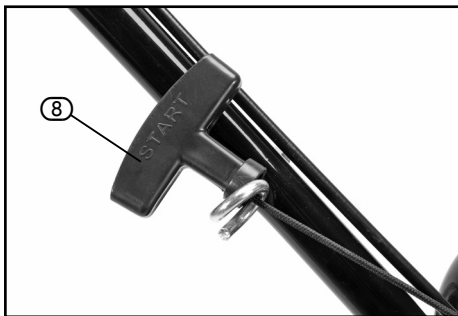

FIG. 14

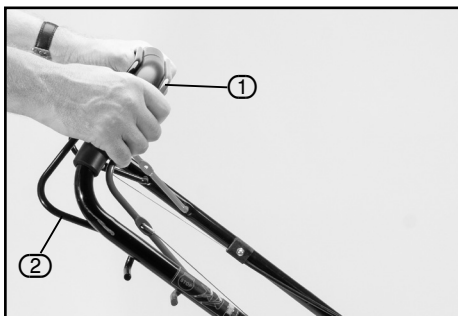

FIG. 15

10. MAINTENANCE

10.1 MAINTENANCE – FIGS. 16 – 21

Regular inspection and cleaning reduces the necessity for maintenance operations and will keep your mower in good working condition.

The motor must be correctly ventilated during operation. Avoid blocking the air inlets and vacuum the ventilation slots regularly.

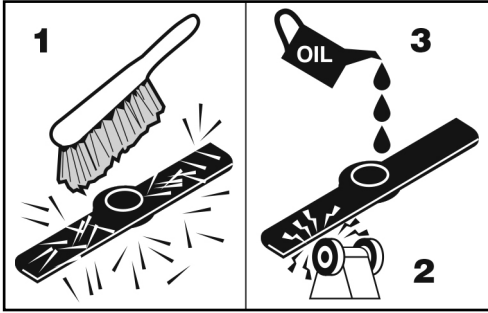

FIG. 16

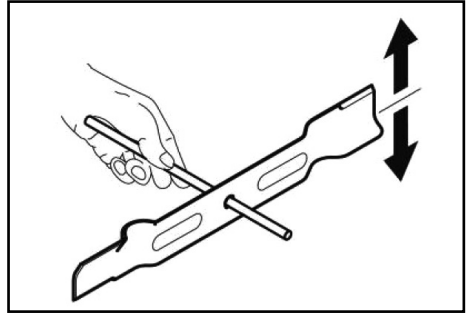

FIG. 17

	12 hours of use	24 hours of use	36 hours of use
Air filter	Clean	Clean	Replace
Spark plug	Check	Clean	Replace
Engine oil	Check	Replace	Check

The engine oil should be changed after the first 8 hours.

How to service the air filter

Soiled air filters reduce the engine output by supply too little air to the carburettor. If the air contains a lot of dust, the air filter should be checked more frequently.

Warning!

Never run the engine without the air filter element installed.

Remove the outside cover. Be careful to prevent dirt and debris from falling into the air filter assembly.

Separate the air filter from the air filter housing.

Inspect the air filter. Clean dirty air filter with warm water and mild soap. Allow it to dry thoroughly before re-installation

Install the air filter assembly onto the carburettor and secure with screw.

Note: Do not use pressurised air or solvents to clean the filter. Pressurised air can damage the filter and solvents will dissolve the filter.



FIG. 18



FIG. 19

10. MAINTENANCE

Replacing the blade

For safety reasons you should only ever have your blade sharpened, balanced and mounted by an authorised service workshop. For optimum results it is recommended that the blade should be inspected once a year.

Warning!

Before you remove the grass collection bag, stop the engine and wait until the blade stops completely. You will need garden gloves (not provided) and a spanner wrench (not provided) to remove the blade. Always handle the blade with care, sharp edges could cause injury. Renew your metal blade after 50 hours mowing or 2 years, whichever is sooner, regardless of condition. If the blade is cracked or damaged replace it with a new one.

Note: Don't invert the mower. Tip it slightly towards the oil filler pipe and reach under the deck. Maintain the sharpness of the blade when cutting grass. If the blade has worn excessively and become pitted and blunt, it should be replaced or sharpened. The sharpness of the blade will affect the performance of the lawnmower.

Hold the blade and unscrew the blade bolt counter-clockwise, using a spanner wrench. Remove the washer and the blade.

Fit the new or re-sharpened blade by putting it on the two studs on the blade flange and then replacing the washer and bolts. Make sure the blade is correctly located, and then firmly tighten the bolt. Do not over tighten. The up turn of the blade must project into the motor compartment.

Cleaning a flooded engine

Note: If the engine won't start after you have operated the starter several times, the engine may be flooded with excess fuel. Use following procedure to clear and start a flooded engine.

Release the engine start/stop lever to stop engine.

When cool, remove the spark plug, dry it, and then reinstall it.

To clean it, use a wire brush.

Note: Install the spark plug carefully by hand to avoid cross-threading. After the plug is seated tighten 1/8 to 1/4 turn with socket spanner of spark plug to compress the washer.



FIG. 20

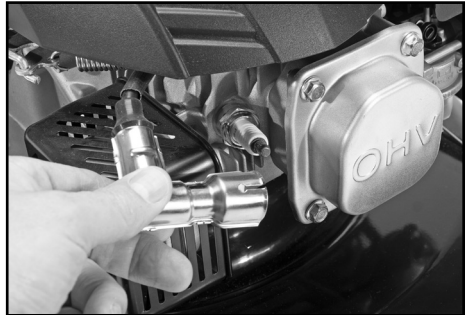

FIG. 21

11. TROUBLESHOOTING

11.1 TROUBLESHOOTING GUIDE

Problem	Possible Cause	Remedy
Engine does not start.	Spark plug is defective. Cutting blade is worn or damaged. Fuel tank is empty. Engine may be flooded.	Replace spark plug. Replace it by contacting Draper or service agent. Refill with fuel. Remove plug and dry.
Machine vibrates in use.	Screws are loose. Blade fasteners are loose. Blade is unbalanced.	Check screws. Check blade fasteners. Replace blade.
Engine runs unsteadily.	Air filter is soiled. Spark plug is soiled.	Clean the air filter. Clean the spark plug.
Uneven mowing results.	Blade is blunt. Cutting height is too low.	Re-sharpen or replace the blade. Set higher.
Mower does not pick up grass cuttings.	Blade is worn. Grass bag is full or clogged. Cutting height is right. The grass is wet. The discharge channel/ housing is blocked. The underside of the deck is clogged.	Replace the blade. Empty the grass bag. Correct the cutting height. Allow the grass to dry. Clean the discharge channel/ housing. Clean the underside of the deck.

12. EXPLANATION OF SYMBOLS

12.1 EXPLANATION OF SYMBOLS



Warning!



Pay more attention to the operator's hands and feet to avoid injury.



Caution!
Engine hot.



Fuel is flammable, keep fire away.



Danger!
Risk of flying debris.



Do not use this machine on slopes greater than 16.7°.



Danger!
Beware of sharp blades.



Don't operate inside house.



Read the instruction manual.



Warning!
Wear suitable eye and ear protection.



Warning!
Keep bystanders away.



Warning!
Wear suitable footwear



When repairing, please remove the spark plug, then repair it according to operational manual.



Continuous A-Weighted Sound Pressure Level.

13. DISPOSAL

13.1 DISPOSAL

- At the end of the machine's working life, or when it can no longer be repaired, ensure that it is disposed of according to national regulations.
- Contact your local authority for details of collection schemes in your area.

In all circumstances:

- Do not dispose of power tools with domestic waste.
- Do not incinerate.
- Do not dispose of WEEE* as unsorted municipal waste.



* Waste Electrical & Electronic Equipment.

CONTACTS

**Draper Tools Limited, Hursley Road,
Chandler's Ford, Eastleigh, Hampshire. SO53 1YF. U.K.**

**Delta International BV
Oude Graaf 8, 6002 NL, Weert, Netherlands**

Help line: (023) 8049 4344

Sales desk: (023) 8049 4333

Internet: drapertools.com

E-mail: sales@drapertools.com

General enquiries: (023) 8026 6355

**Service/Warranty Repair Agent:
For aftersales servicing or warranty repairs, please contact the
Draper Tools help line for details of an agent in your local area.**

YOUR DRAPER STOCKIST

0125

©Published by Draper Tools Limited.

No part of this publication may be reproduced, stored in a retrieval system or transmitted in any form or by any means, electronic, mechanical photocopying, recording or otherwise without prior permission in writing from Draper Tools Ltd.