

EN

Original Instructions
Version 2 - 10/24

DRAPER[®]

HAND
PALLET TRUCK

85655



1. Preface

1.1 Product Reference

User Manual for: Hand Pallet Truck

Stock No: 85655

Part No: PT2500-B

1.2 Revisions

Version 1: November 2017

First release

Version 2: October 2024

General format and text amends

2. Product Introduction

2.1 Intended Use

This hand operated pallet truck is designed ideally for use in warehouse environments.

Any other application beyond the conditions established for use will be considered misuse. Draper Tools accepts no responsibility for improper use of this product.

Read this manual in full before using this product and retain it for future use. Always use the latest version of the manual. Please visit drapertools.com/manuals for the latest version.

2.2 Specification

Stock No.	85655
Part No.	PT2500-B
Maximum Lifting Capacity	2500kg
Maximum Fork Height	200mm
Minimum Fork Height	85mm
Fork Length	1150mm
Fork Width (overall)	540mm
Load Wheel Diameter	80mm
Steering Wheel Diameter	200mm
Net Weight	72kg

3. Health and Safety Information

Important: Read all the Health and Safety instructions before attempting to operate, maintain or repair this product. Failure to follow these instructions may result in injury or damage to the user, the product or the load.

3.1 General Health and Safety Information

- The operator **MUST** watch the lifting device and the load during all movements.
- The user shall not work under the raised load until it is secured by suitable means.

- Limitations – **DO NOT** use for:
 - operations in severe conditions (e.g. extreme climates, freezer applications, strong magnetic fields etc.).
 - operations subject to special rules (e.g. potentially explosive atmospheres, mines etc.).
 - lifting of persons.



CAUTION!

- **DO NOT** handle loads, the nature of which, could lead to dangerous situations (e.g. molten metals, acids, radiating materials or brittle loads).

- The service life of the hydraulic fluid is approximately 2 years and the equipment 2-5 years. During decommissioning of the equipment certain hazards should be understood and avoided.
- Dealing with hydraulic fluid - refer to the hydraulic fluid sections 3.2 & 7.2 for details.
- Only with the line pressure released and with the lifting arm fully lowered shall the equipment be disassembled. Eye protection should be worn in case any high-pressure hydraulic fluid is ejected.
- This equipment poses a significant trapping/crushing hazard and as such extreme caution should be taken when handling/operating.
- Use only on a smooth, dry, level, firm good condition surface.
- **DO NOT** exceed the rated capacity of the truck.
- This is a lifting device only and is not designed or intended to be used for any other purpose.
- Familiarise yourself with this manual before operating this equipment to prevent damage to property, equipment or personal injury.

 **WARNING! For safe operation of this Pallet Truck, read the following instructions:**

- Only trained personnel should use this pallet truck.
- **DO NOT** operate the pallet truck until you have checked its condition. Give special attention to the wheels, handle, forks, lift and lower control. **DO NOT** operate a damaged or faulty truck.
- **DO NOT** attempt repairs unless you are trained and authorised to do so.
- Operate only from the designated operating position. Never place any part of your body in the lifting mechanism or under the forks or load. **DO NOT** carry passengers.
- **DO NOT** handle unstable or loosely stacked loads.
- Use special care when handling long, high or wide loads to avoid losing the load, striking bystanders or tipping the truck.
- **DO NOT** overload the truck. Check the rating plate for carrying and lifting capacity information. Overloading may cause the truck to perform incorrectly and could cause injury.
- The capacity of the truck assumes an evenly distributed load with the centre of the load being at the halfway point of the length of the forks.
- Make sure the length of the forks matches the length of the pallet.
- Lower the forks to the lowest height position when the truck is not to be used.
- Manual pallet trucks are for general operation on level, flat, hard surfaces. If ramps are encountered, the truck may be stopped in emergencies by operating the lowering control which will lower the load to the ground, stopping the truck. If the truck has to be stopped in this manner care should be taken that no part of your body is near or under the load. It is important not to operate a manual pallet truck on a grade with loads that are too heavy to be easily handled by the operator. Since these are manually operated trucks, they are not to be used by operators that are not physically capable of safely handling the trucks with a load.
- The truck shall be used, serviced and repaired according to the manufacturer and shall not be modified or attachments fitted.
- The truck should only be used in places with sufficient illumination.
- The truck shall not be turned at right angles to stop the truck.
- **DO NOT** use the truck as a vehicle jack.
- The extremity of fork arms shall not be used as a lever to lift a load.
- The truck shall not be used in applications where a risk of exceeding the rated capacity exists.
- The truck shall not have direct contact with foodstuffs.
- The truck shall not be used in a potentially explosive atmosphere.
- Have this tool repaired by a qualified person. This tool is designed to conform to the relevant international and local standards and as such should be maintained and repaired by someone qualified; using only original parts supplied by the manufacturer: This will ensure the equipment remains safe to use.

FAILURE TO FOLLOW THESE INSTRUCTIONS COULD RESULT IN LOSS OF LOAD AND/OR PERSONAL INJURY OR DAMAGE TO PROPERTY

3.2 Hydraulic Fluid Safety Information

- Always wear gloves and eye protection when dealing with hydraulic fluid.
- Hydraulic fluid composition is achieved when mineral oil is highly refined by means of a solvent. As a substance it is not considered hazardous to health under normal conditions of use.

3. Health and Safety Information

• First Aid recommendations

- **In case of ingestion:** Wash out mouth with clean water and seek medical advice. **DO NOT** induce vomiting.
 - **In case of contact with eyes:** Thoroughly flush eyes with clean water for 5 to 10 minutes and seek medical advice.
 - **In case of contact with skin:** Wash area with soap and water. Remove affected clothing and wash. If irritation persists, seek medical advice.
 - **Other:** Seek medical advice immediately.
- Hydraulic fluid is a combustible material and in the event of fire should be extinguished using a foam or dry powder fire extinguisher. **DO NOT** use water.
 - In the event of accidental release into the environment, measures to prevent spread must be adhered to.
 - **DO NOT** contaminate rivers, waterways or drains. Spillage should be contained with sand, grit or other appropriate barriers. Warn bystanders as spillage may present a slip hazard.
 - Hydraulic fluid is not biodegradable.

4. Identification and Unpacking

Carefully remove the product from the packaging and examine it for any signs of damage that may have occurred during shipment. If any part is damaged or

missing, do not attempt to use the product. Please contact the Draper Helpline; contact details can be found at the back of this manual.

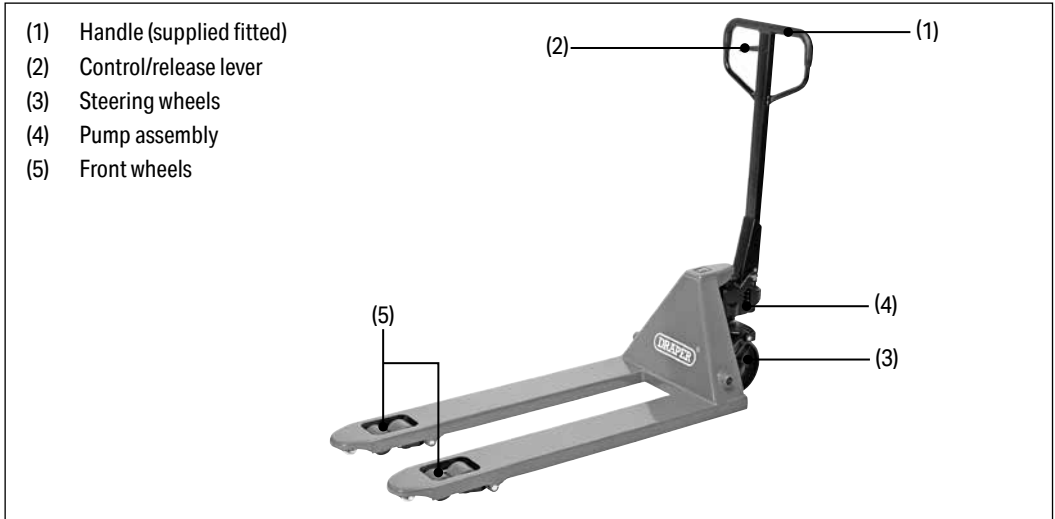

5. Setting Up the Pallet Truck

Important: Before operating this product, read and understand all the safety instructions listed in this manual. Ensure that the product is fully assembled and correctly prepared for use.

5.1 Hydraulic Valve Adjustment

On the handle of the pallet truck, the control lever has three operating positions:

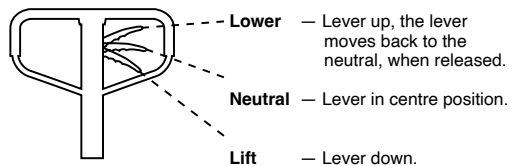

5. Setting Up the Pallet Truck

If required, adjust the lever following the steps below:

- If the forks elevate while pumping in the **Neutral** position, turn the adjusting nut on the adjusting bolt clockwise until pumping action does not raise the forks and the **Neutral** position works properly.
- If the forks descend while pumping in the **Neutral** position, turn the adjusting nut counter-clockwise until the forks do not lower.

- If the forks do not descend when the control lever is in the **Lower** position, turn the adjusting nut clockwise until raising the control lever lowers the forks. Then check the **neutral** position works properly.
- If the forks do not elevate while pumping in the **Lift** position, turn the adjusting nut counter-clockwise until the forks elevate while pumping in the **Lift** position. Then check the **Lower** and **Neutral** position.

6. Pallet Truck Operation

- DO NOT** use this pallet truck unless you are trained and authorised to do so.
- Ensure the pallets used are suitable for use with this pallet truck.

6.1 Lifting and Lowering the Pallet Truck

- To lift the load** - ensure that it is evenly distributed over both the forks and that the load to be lifted does not exceed 2500kg. Ensure the lever is in the down position so when the handle is lowered the load will be lifted.
- To move the load** - ensure the lever is in the neutral position. Ensure the flooring meets the requirements of the load and ensure it is free of obstacles.
- To lower the load** - gently lift the lever to the lower position. This will lower the pallet to the floor. Ensure nothing is under the pallet when lowering, e.g. feet.
- When the truck is not in use** - ensure the forks are lowered and the lever is in the neutral position.

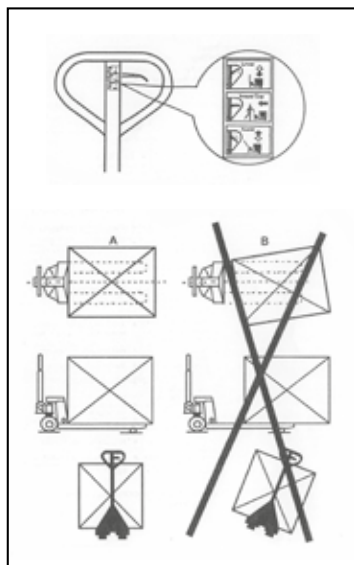

7. Maintenance and Troubleshooting

Regularly inspect and carry out routine maintenance on the pallet truck to keep in good working condition.

7.1 Daily Check and Maintenance

- Check the overall condition of the pallet truck daily.
- Keep clean and lubricate all the moving parts at regular intervals using motor oil or grease. Pay special attention to the wheels, axles, threads etc.
- The forks should be unloaded and lowered in the lowest position when the job is complete and when the truck is not in use.

7.2 Hydraulic Oil Check

- Check the oil level every 4 months. The oil capacity is approximately 300mls.
- Use the hydraulic oil between -20°C to 40°C.

7.3 Expelling Air from the Pump Unit

- Air may come into contact with the hydraulic oil during transportation or if the pump is stored in an upset position. It can stop the forks lifting while pumping in the 'RAISE' position.
- Release the air by selecting the lowest position on the control handle, then move the handle up and down several times.

7. Maintenance and Troubleshooting

7.4 Reattaching the Handle to the Pistons



Offer the handle up to the piston's pre-drilled holes.

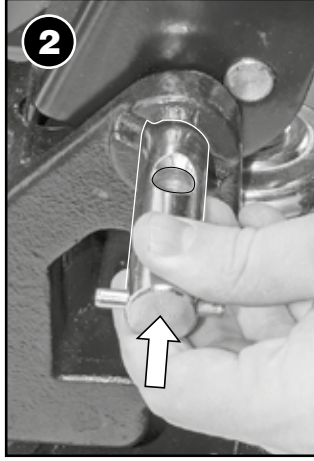

Whilst holding the handle in place slide the axle pin through the handle.

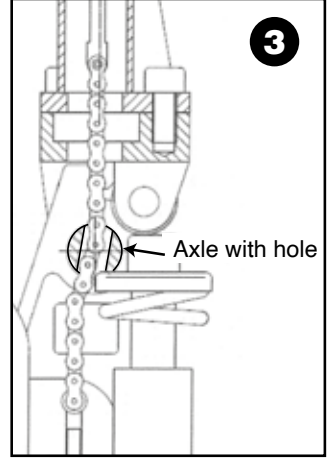

Adjust the control lever to the lower position. Then feed the chain and adjusting bolt/nut through the axle pin.

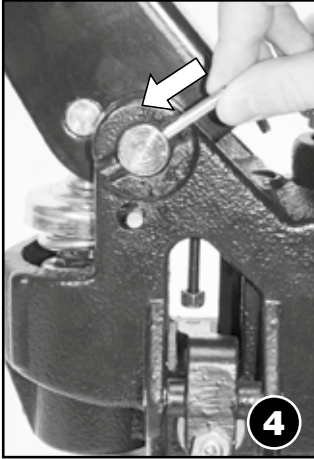

Secure the axle pin by locating the dowel pin (soft face hammer required).

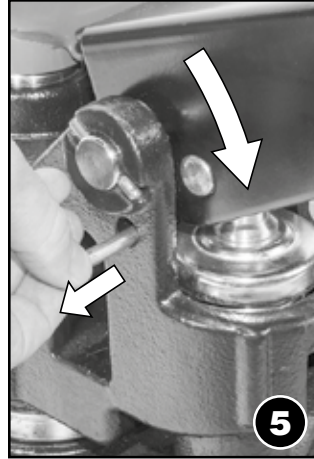

Push the handle down and remove the pump securing pin.

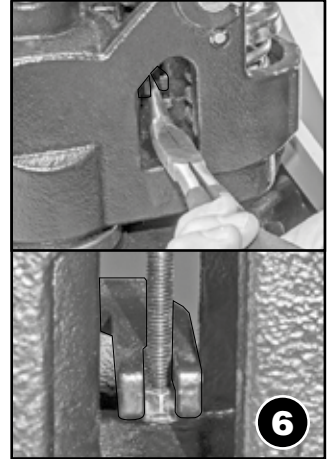

Adjust the control lever to the 'Lift' position. This will extend the length of the chain and adjusting bolt/nut. Lift the lever plate and slide the adjusting bolt through the slot.

Note: Using a curved tool/ pry bar/curved pliers and allow enough clearance for the adjusting bolt to slide through the slot.

7. Maintenance and Troubleshooting

7.5 Troubleshooting

Problem	Possible Cause	Remedy
Forks cannot be raised to the maximum height.	Hydraulic oil is low.	Fill up the oil.
Forks cannot be raised.	No hydraulic oil.	Fill up the oil.
	The oil is contaminated/has impurities.	Change the oil.
	Air in the hydraulic oil.	Purge the air from the oil. Refer to section 7.3.
Forks cannot be lowered.	The piston rod or pump body is deformed resulting from partial loading, slanting to one side or overloading.	Contact Draper Tools for advice.
	The fork was kept in the high position for a long time with the piston rod bared allowing it to rust and jam the rod.	Keep the forks in the lowest position when not in use. Lubricate the rods more frequently.
Oil leaks.	Seals worn or damaged.	Replace worn or damaged parts and seals.
	Parts cracked or worn.	Contact Draper Tools for advice.
Forks lower without the release valve working.	Impurities in the oil prevent the release valve from closing tight.	Replace with new oil.
	Parts of the hydraulic system cracked or worn. Seals worn or damaged.	Inspect and replace worn parts. Contact Draper Tools for advice.
	Air in the hydraulic oil.	Purge the air from the oil. Refer to section 7.3.

8. Disposal and Warranty

At the end of its working life, dispose of the product responsibly and in line with local regulations. Recycle where possible.

12 months -
Visit drapertools.com/warranty for full details.

Dispose of oil separately and in accordance with local regulations; **DO NOT** abandon it in the environment.



Contact Details

Draper Tools

Draper Tools Limited
Hursley Road
Chandler's Ford
Eastleigh
Hampshire
SO53 1YF
UK

Website: drapertools.com

Email: sales@drapertools.com

Product Helpline: +44 (0) 23 8049 4344

Telephone Sales Desk: +44 (0) 23 8049 4333

General Enquiries: +44 (0) 23 8026 6355

Delta International

Delta International BV
Oude Graaf 8
6002 NL
Weert
Netherlands

Please contact the Draper Tools Product Helpline for repair and servicing enquiries.