

EN

Original Instructions
Version 3

DRAPER[®]

DUAL ACTION AIR

COMPOSITE SANDER

65084



UK
CA **CE**

These are the original product instructions. This document is part of the product; retain it for the life of the product, passing it on to subsequent holders. Read this manual in full before attempting to assemble, operate or maintain this product.

This Draper Tools manual describes the purpose of the product and contains all the necessary information to ensure its correct and safe use. Following all the instructions and guidance in this manual will ensure the safety of both the product and the operator and increase the lifespan of the product.

All photographs and drawings within this manual are supplied by Draper Tools to help illustrate correct operation of the product.

Every effort has been made to ensure the information contained in this manual is accurate. However, Draper Tools reserves the right to amend this document without prior warning. Always use the latest version of the product manual.

1.1 Product Reference

User Manual for: Dual Action Air Composite Sander

Stock No: 65084

Part No: DAT-APS-SF

1.2 Revisions

Version 1: November 2014

First release

Version 2: July 2020

Updates to formatting and product marking

Version 3: May 2023

General content and formatting updates

Addition of retaining clip instructions

As our manuals are continually updated, always ensure that the latest version is used.

Please visit drapertools.com/manuals for the latest version of this manual and the associated parts list, if applicable.

1.3 Understanding the Safety Content of This Manual



WARNING! – Situations or actions that may result in personal injury or death.



CAUTION! – Situations or actions that may result in damage to the product or surroundings.

Important: – Information or instructions of particular importance.

1.4 Copyright © Notice

Copyright © Draper Tools Limited.

Permission is granted to reproduce this manual for personal and educational use **ONLY**. Commercial copying, redistribution, hiring or lending is strictly prohibited.

No part of this manual may be stored in a retrieval system or transmitted in any other form or means without written permission from Draper Tools Limited.

In all cases, this copyright notice must remain intact.

| | |
|--|----|
| 1. Preface | 2 |
| 1.1 Product Reference | 2 |
| 1.2 Revisions | 2 |
| 1.3 Understanding the Safety Content of This Manual | 2 |
| 1.4 Copyright © Notice | 2 |
| 2. Contents | 3 |
| 3. Product Introduction | 4 |
| 3.1 Intended Use | 4 |
| 3.2 Specification | 4 |
| 4. Health and Safety Information | 5 |
| 4.1 Health and Safety Instructions for this Air Sander | 5 |
| 4.2 Additional Safety Instructions for Pneumatic Tools | 7 |
| 4.3 Residual Risk | 7 |
| 5. Identification and Unpacking | 8 |
| 5.1 Product Overview | 8 |
| 5.2 What's in the Box? | 9 |
| 5.3 Packaging | 9 |
| 6. Preparation Instructions | 10 |
| 6.1 Air Tool Oil Specification | 10 |
| 6.2 Preparing the Air Supply for Use | 10 |
| 6.3 Connection to the Air Supply | 11 |
| 6.4 Attaching Sanding Pads | 11 |
| 6.5 Dust Extraction | 11 |
| 7. Operating Instructions | 12 |
| 8. Maintenance and Storage | 13 |
| 8.1 General Maintenance | 13 |
| 8.2 Replacing the Backing Plate | 13 |
| 8.4 Troubleshooting | 14 |
| 8.3 Storing the Air Sander | 14 |
| 9. Spares, Returns and Disposal | 15 |
| 10. Warranty | 16 |
| 11. Explanation of Symbols | 17 |

3.1 Intended Use

This product is intended for sanding and smoothing wooden surfaces using both rotary and orbital actions at variable speeds. It is suitable for use with a compressed air supply and centralised dust extraction vacuum systems. Any other application beyond the conditions established for use will be considered misuse. Draper Tools accepts no responsibility for improper use of this product.

Part of our core range, this product is suitable for use by enthusiasts and tradespersons alike.



WARNING! This product is not a toy and must be respected.

Read this manual in full before attempting to assemble, operate or maintain the product and retain it for later use.

3.2 Specification

| | |
|-----------------------------|---------------------|
| Stock No. | 65084 |
| Part No. | DAT-APS-SF |
| Disc diameter: | 150mm (6") |
| Orbit diameter: | 5mm |
| Speed (no load): | 10,500rpm |
| Max. air pressure: | 6.3bar (90psi) |
| Average air consumption: | 85L/min |
| Minimum air line size: | 3/8" inner diameter |
| Air inlet: | 1/4" BSP |
| Spindle thread: | 5/16" x 24 |
| Emissions: | |
| Sound pressure level (LPA): | 85dB(A) |
| Sound power level (LWA): | 96dB(A) |
| Vibration levels: | 6.3m/s |
| Weight (net): | 0.88kg |

Important: The declared vibration total values and noise emissions values have been measured in accordance with a standard test method and may be used for comparing one tool with another. These values may also be used in a preliminary assessment of exposure.



WARNING! The vibration and noise emissions during actual use of the product can differ from the declared values depending on the tool speed and the workpiece upon which it is used. Before each use, estimate the likely exposure resulting from the actual conditions of use. Take into account all parts of the operation cycle in order to identify any safety measures required to protect the operator.

Important: These instructions are intended as a guide to the safe use of this product. Additional or specific risks associated with each operation and workpiece material must be undertaken before each operation. **DO NOT** operate this tool if you are unfamiliar with the risks associated with its use.

4.1 Health and Safety Instructions for this Air Sander



WARNING! Read and understand the safety instructions before installing, operating, repairing, maintaining, replacing accessories, or working near the sander. Failure to do so can result in serious bodily injury.

General Safety Instructions

- Only trained and authorised personnel may install, adjust or operate the sander.
- **DO NOT** modify this sander.
 - Modifications can reduce the effectiveness of safety measures and increase the risk of injury.
- Retain these instructions for the life of the product and pass them on with the tool to any future operators.
- **DO NOT** use this sander if it shows any evidence of damage or disrepair.
- Regularly inspect the sander to ensure that all safety markings remain legible.
 - Contact Draper Tools if the safety markings need to be replaced and **DO NOT** use the tool.

Projectile Hazards

- Be aware that failure of the workpiece, accessories or tool itself may generate high-velocity projectiles.
- **ALWAYS** wear impact-resistant eye protection during operation of the sander and assess the grade of protection required with each use.
- When working overhead, **ALWAYS** wear a safety helmet.
- Carefully assess the risk to others before every operation and ensure that all bystanders are clear of the work area or equipped with suitable protective equipment.
 - Keep this product out of reach of children at all times.
- **ALWAYS** ensure that the workpiece is firmly gripped by a clamp or vice; **NEVER** hold the workpiece by hand.

Entanglement Hazards

- Keep loose clothing, gloves, hair and jewellery well away from the sander at all times.
 - Entanglement in the spinning pad can cause significant injury.

Operating Hazards

- Wear suitable protective gloves to guard against injury from cuts, abrasion and heat.
- If the workpiece becomes hot during operation, stop the tool and allow the material to cool before continuing.
- Hold the tool correctly and firmly and brace yourself against sudden movements, keeping both hands available.
- Maintain good balance and secure footing at all times while operating the tool.
- Release the trigger lever immediately if the air supply is interrupted.
- **ONLY** use lubricants recommended by Draper Tools.
- **ALWAYS** wear protective safety glasses while using this tool.
 - Draper Tools also recommends wearing protective gloves and other protective clothing appropriate to the specific conditions of the operation.
- Inspect the backing plate for signs of damage before **EVERY** use.
 - **DO NOT** use the sander if the backing pad is broken or cracked or the tool has been dropped.
- **NEVER** touch the backing plate or sanding sheet while the tool is in operation.
 - **ALWAYS** allow the tool to come to a complete stop and disconnect the air supply before handling or adjusting the sanding pad or backing plate.
- **NEVER** use the tool without a suitable sanding pad attached.
- Use on plastic or other non-conductive materials increases the risk of electrostatic discharge.
- Dust and fumes caused by sanding operations may create potentially explosive environments.
 - **ALWAYS** ensure that dust extraction or suppression systems are used with this tool and are suitable for use with the workpiece materials.

Repetitive Motion Hazards

- When operating a sander frequently or for extended periods, the operator may experience discomfort in the hands, arms, shoulders, neck and other parts of the body.
- While using the sander, adopt a comfortable posture while maintaining secure footing and avoiding awkward or off-balance positions.
 - Change posture and operating positions regularly during extended use to help avoid discomfort and fatigue.
- **DO NOT** ignore symptoms such as persistent or recurring discomfort, pain, throbbing, aching, tingling, numbness or burning sensations.
 - If these symptoms occur, stop using the tool and consult a qualified health professional.

Accessory Hazards

- **ALWAYS** disconnect the sander from the air supply before fitting or changing accessories.
- Avoid direct contact with the sanding pad and backing plate during and immediately after operation as it may become hot during use.
- **ONLY** use accessory types and sizes recommended by Draper Tools.
- **DO NOT** attach grinding wheels or cutting-off accessories to this tool and do not use it for these purposes.
- **ALWAYS** ensure that the maximum operating speed of the backing pad is higher than the rated speed of the sander.
- Self-fixing sander discs must be placed concentrically on the supporting pad.

Workplace Hazards

- Stay alert for surfaces that may become slippery as a result of use of this tool and for trip hazards caused by the air line.
- This sander is not suitable for use in potentially explosive atmospheres and is not insulated against contact with electric power.
- Ensure that there are no electrical cables, gas pipes, etc. present in the workpiece that may cause a hazard if damaged by the tool.

Dust and Fume Hazards

- Dust and fumes generated by sanding operations can cause ill health (e.g., cancer, birth defects, asthma and/or dermatitis).
 - Perform a risk assessment and implement any appropriate controls for identified hazards before performing any operation.
 - Any risk assessment performed must include dust created by use of the tool and disturbance of any existing dust.
- Operate and maintain the sander appropriately to minimise the dust or fume emissions.
- Direct the exhaust so as to minimise disturbance of existing dust in dusty environments.
- Where dust or fumes are created, priority must be given to controlling them at the point of emission.
- All integral features and accessories for the collection, extraction or suppression of airborne dust or fumes must be correctly used and maintained in accordance with the manufacturer's instructions.
- Select, maintain and replace the backing plate and sanding pads as recommended in the manual to prevent any unnecessary increase in the emission of dust or fumes.
- Use appropriate respiratory protection in accordance with local occupational health and safety regulations.

Noise Hazards

- Exposure to high noise levels can cause permanent hearing loss and other problems.
 - Perform a risk assessment and implement any appropriate controls for identified hazards before performing any operation.
- Implement appropriate controls, such as dampening materials, to prevent the workpiece from "ringing" during operation.
- Use appropriate hearing protection in accordance with local occupational health and safety regulations.
- Operate and maintain the sander appropriately to prevent unnecessary increase in noise emissions.

Vibration Hazards

- Exposure to vibration can cause disabling damage to the nerves and blood supply of the hands and arms.
- Wear warm clothing when working in cold conditions and keep your hands warm and dry.
- If you experience numbness, tingling, pain or whitening of the skin in your fingers or hands, stop using the sander and consult a qualified health professional.
- Operate and maintain the sander appropriately to prevent unnecessary increase in vibration emissions.
- The risks from vibration hazards are increased when grip force on the tool is higher.
 - Hold the sander with a light but safe grip, keeping in mind that your grip may need to be altered to react to unexpected forces.

4.2 Additional Safety Instructions for Pneumatic Tools



WARNING!

Compressed air can cause severe injury.

- **ALWAYS** turn off and disconnect the air supply before making any adjustments or repairs to the product or leaving it unattended.
- **NEVER** direct compressed air towards yourself or others.
- Ensure that compressed air is not blocked by or in contact with any part of your body.
- **ONLY** use clean, dry and regulated compressed air.



WARNING! NEVER use oxygen, combustible gases or other bottled gases as a supply for this product. Use of these substances may cause the product to explode.

- Draper Tools recommends the use of a whip hose between the tool and the air supply to reduce vibration.



WARNING! Whipping hoses can cause severe injury. Always check for and replace damaged or loose hoses and fittings.

- Ensure that the product is compatible with the air supply before use.
- Ensure all connections are securely tightened.

- Where universal twist couplings (claw couplings) are used, lock pins must be installed and whipcheck safety cables must be used to safeguard against possible hose-to-tool or hose-to-hose failure.
- **DO NOT** exceed the maximum stated air pressure.
- **DO NOT** obstruct the ability of the trigger to release once depressed.
- **NEVER** carry the tool by the air line.

4.3 Residual Risk

The safety instructions in this manual cannot account for all possible conditions and situations that may occur. Exercise common sense and caution when using this product and protect against any additional conceivable risks.

5.1 Product Overview



- (1) Air line inlet
- (2) Backing plate
- (3) Dust outlet
- (4) Exhaust
- (5) Inlet bung

- (6) Retaining clip
- (7) Shroud
- (8) Speed control lever
- (9) Trigger lever

5. Identification and Unpacking

EN

5.2 What's in the Box?

Carefully remove the product from the packaging and examine it for any signs of damage that may have occurred during shipment.

Before assembling the product, lay the contents out and check them against the parts shown below. If any part is damaged or missing, do not attempt to use the product. Please contact the Draper Helpline; contact details can be found at the back of this manual.

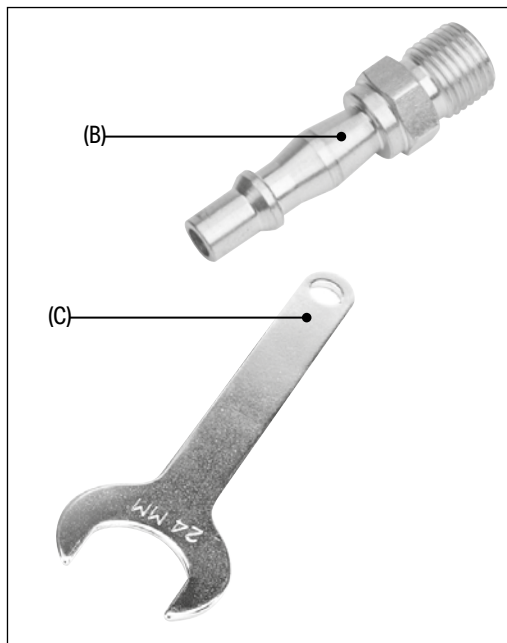

- (A) 1 x Air sander (not shown)
- (B) 1 x Air line coupling
- (C) 1 x 24mm (M16) spanner

5.3 Packaging

Keep the product packaging for the duration of the warranty period for reference should the product need to be returned for repair.

WARNING! Keep packaging materials out of reach of children. Dispose of packaging correctly and responsibly and in accordance with local regulations.

Please visit drapertools.com for our full range of accessories and consumables.

6. Preparation Instructions

Important: Before operating this product, read and understand all the safety and preparation instructions listed in this manual.

6.1 Air Tool Oil Specification

Air tool oil viscosity refers to the thickness and flow of the oil used in the product and the way in which it reacts with heat. Liquids with low viscosity are thinner than liquids with high viscosity.

As the viscosity of the air tool oil is reduced when heated, choosing the right viscosity is essential. If the oil viscosity is too low, it may not lubricate the tool

appropriately when heated. If the oil viscosity is too high, the fluid may cause excessive resistance within the air lines when cold.

ISO grade 22–32 (SAE grade 5W–15W) monograde oil should be used in this product. Draper Tools recommends the use of Draper Air Tool Oil:

- **500ml:** Stock No. 34681
- **1L:** Stock No. 34862

During use, the oil must be constantly supplied to the equipment to ensure complete lubrication and optimum performance.

6.2 Preparing the Air Supply for Use

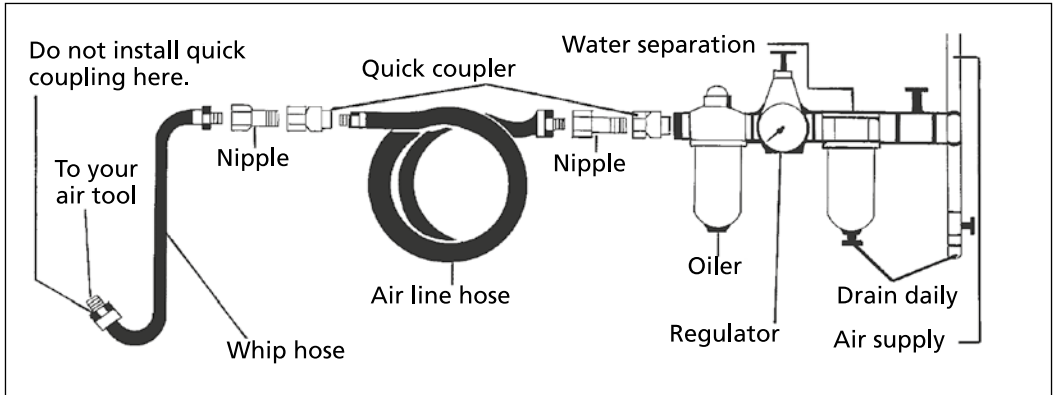

Fig. 1

This air tool operates at a max. pressure of 6.3bar (90psi).

The compressed air system must be controlled by a combination pressure regulator, in-line lubricator and moisture filter. This will ensure a constant supply of dry air at all times, provided it is properly maintained.

Important: Always check the machine operating pressure before use.

Water in the compressor tank may cause considerable corrosion to air tools; the compressor should be drained daily to avoid excessive water in the air supply. Dirty or wet air can significantly shorten the lifespan of the product.

When using an air tool with a hose over 25ft long, Draper Tools recommends increasing the bore of the hose to the next largest available size (i.e. increase 3/8" to 1/2"). This will ensure adequate pressure and volume of air to power the tool.

6.3 Connection to the Air Supply

Important: Draper Tools recommends using a 1/4" BSP male-threaded thread whip hose (Stock No. 54438, not supplied) to connect the spray gun to an air line in order to reduce vibration.

WARNING! To prevent unintentional starting, **ALWAYS** ensure that the retaining clip is installed and that the trigger lever is not depressed while connecting the air line.

1. Wrap a length of PTFE tape around the air line coupling (B) or whip hose thread.
Important: For a more secure seal, the PTFE tape should be wrapped in the opposite direction to the thread.
2. Remove the inlet bung (5) and screw the air line coupling or whip hose into the tool air line inlet (1).

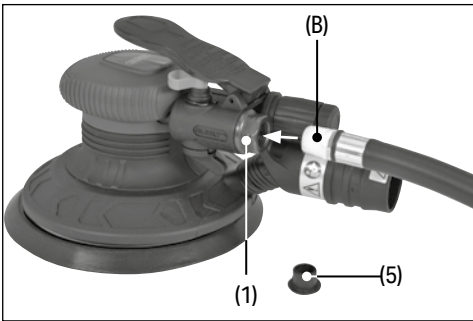

Fig. 2

3. Connect the air line to the air line coupling or whip hose.
4. Pressurise the air line when you are ready to begin.

6.4 Attaching Sanding Pads

Important: ALWAYS ensure that the air line is disconnected before installing, adjusting or removing sanding pads.

This product is compatible with hook-and-loop-backed sanding pads.

To install a sanding pad, align the edges and holes of the sheet with the backing plate and press it firmly into place.

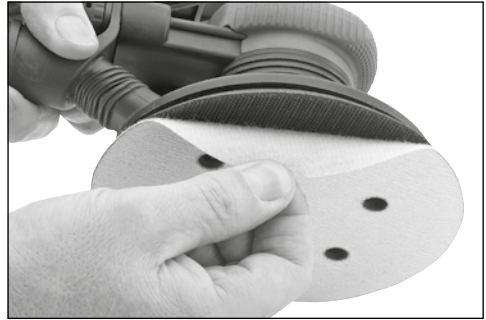

Fig. 3

Sanding pads should be replaced when they become damaged, excessively worn or fail to wear the workpiece appropriately during use.

Important: If the sanding pad is not punched, use a suitable tool to pierce the sheet in line with the backing plate openings. This allows dust to be extracted from the workpiece and reduces the risk of inhalation.

CAUTION! The sanding pad **MUST** be suitably sized for the backing plate. Use of over- or under-sized pads may cause significant damage to the backing plate or spindle.

6.5 Dust Extraction

Important: To reduce the risk to health, **ALWAYS** use appropriate dust extraction facilities when working with this tool.

Firmly insert a suitable dust extraction hose (not supplied) into the dust outlet (3) and attach the other end of the hose to an appropriate dust extractor.

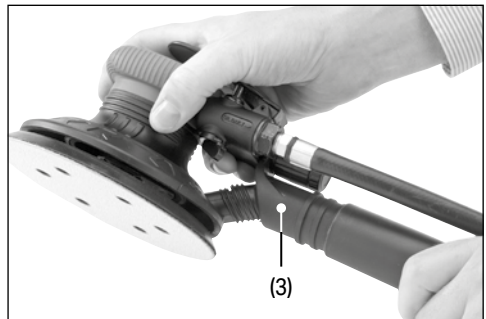

Fig. 4

7. Operating Instructions

Important: ALWAYS ensure that the product is correctly prepared and lubricated before operation. Read all the safety and preparation instructions in this manual before use.

WARNING! The workpiece **MUST** be firmly secured in place before operation. **DO NOT** hold the workpiece by hand.

1. Ensure that the air line is securely connected and pressurised.
2. Rotate the exhaust (4) to position it so that any disturbance of existing dust or dust generated by the operation is minimised.
3. Pull the retaining clip (6) out from under the trigger lever (9) to remove it and retain it for future use.

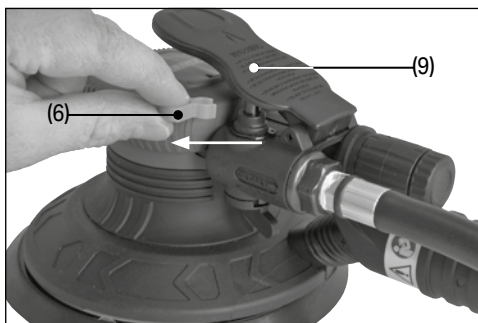

Fig. 5

CAUTION! **DO NOT** attempt to operate the tool with the retaining clip still in place.

4. Place the tool against the workpiece and depress the trigger lever to start the tool.
Important: Start the operation with the tool against the workpiece to prevent gouging upon first contact.

5. Adjust the position of the speed control lever (8) to alter the airflow into the tool and set the sanding speed as appropriate.

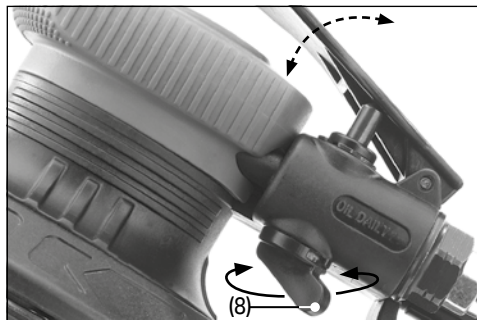

Fig. 6

6. To stop the tool, release the trigger lever as you lift it away from the workpiece.

Important: Reinstall the retaining clip and depressurise and disconnect the air line when the tool is not in use for extended periods.

The direction of rotation is indicated on the shroud (7).

Important: When operating the sander, use only the flat surface of the sanding pad against the workpiece; **DO NOT** use the edges of the sanding pad and backing plate.

Important: ALWAYS ensure that the air supply is disconnected from the tool before performing any maintenance or storing the product.

8.1 General Maintenance

- Keep the air line inlet, exhaust and dust outlet free from dust, debris and other obstructions.
- Regularly check the tightness of the backing plate to ensure a firm fit that does not exhibit resistance when rotated.
- Periodically check the sanding pads and backing sheets for damage or wear and replace them as necessary.
- Keep the hook and eye pad of the backing plate free from debris to ensure a secure grip on the sanding pad.
- Lubricate the mechanism by pouring a few drops of air tool oil into the air line inlet before and after every use.
- Ensure that the air line is sufficiently lubricated and apply additional lubrication into the air line inlet if evidence of binding occurs.
- Maintain the air line appropriately:
 - Drain the compressor reservoir and air lines of condensate and dispose of the liquid appropriately.
 - Drain the water trap.
 - Drain and fill the combined separator filter, regulator and lubricant reservoir.
 - Ensure that the air line pressure is appropriate for the tool.

8.2 Replacing the Backing Plate

The backing plate should be replaced if it becomes damaged, can no longer be sufficiently fastened, or no longer grips the sanding pads securely.

1. Lift the rubber shroud (7) slightly and locate the spindle locking nut.
2. Insert the 24mm spanner (C) under the shroud and locate it around the spindle locking nut.

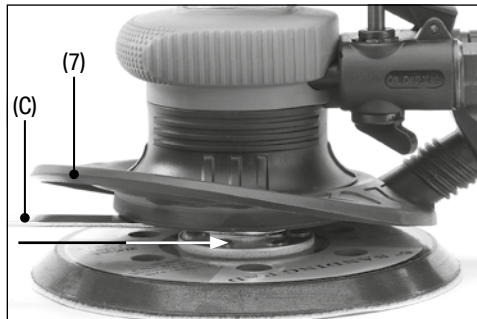

Fig. 7

3. Use the spanner to hold the spindle locking nut in place and rotate the backing plate (2) forwards as indicated on the shroud.

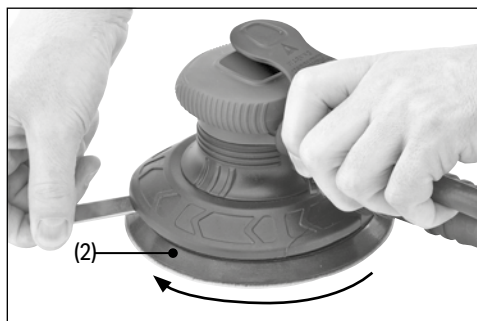

Fig. 8

4. Install a new backing plate onto the spindle, using the spanner to hold the locking nut in place and rotating the plate in the reverse direction.



CAUTION! DO NOT overtighten the backing plate as this may restrict the motion of the plate.

Important: ALWAYS ensure that the spanner has been removed before reconnecting the air line.

8.3 Storing the Air Sander

- Disconnect the air line and remove the air line coupling or whip hose when storing the product.
Important: Lubricate the mechanism by pouring a few drops of air tool oil into the air line coupling and depressing the trigger lever several times before storage.

- Wipe the sander clean and remove any obstructions from the dust outlet (3) before storage.
- Ensure that the retaining clip (6) is installed beneath the trigger lever (9).
- Store the product in a clean and dry location, out of reach of children.

8.4 Troubleshooting

| Problem | Possible Cause | Remedy |
|---|---|--|
| The sander no longer operates. | The air pressure is too low. | Check that the air line is connected and not damaged. |
| | The trigger mechanism has malfunctioned. | Inspect and repair the trigger mechanism as necessary. Pour a little air tool oil into the air line inlet and squeeze the trigger several times. |
| The sander operates with reduced power. | The air line is obstructed. | Switch off and detach the air line. Clean the air line and air inlet and remove any obstructions. |
| | The air pressure is low. | Check the CFM rating of the air compressor, set the pressure appropriately, and check for loose connections. |
| | The rotor vane is seized. | Pour a little air tool oil into the air line inlet and squeeze the trigger several times. |
| The trigger is stiff or resists excessively when depressed, or does not release easily. | The hydraulics mechanism requires lubrication or is obstructed. | Pour a little air tool oil into the air line inlet and squeeze the trigger several times. |
| The spindle does not turn. | The rotor vane is broken. | Contact Draper Tools for support. |
| The tool will not switch off. | The o-rings at the throttle valve are broken or dislodged. | Replace the o-ring seal or contact Draper Tools for support. |

If the issue cannot be resolved, contact Draper Tools for support.

9. Spares, Returns and Disposal

For spare parts, servicing, and repair and replacement options, please contact the Draper Tools Product Helpline for details of your nearest authorised agent.

Draper Tools will endeavour to hold any spare parts, if applicable, for seven years from the date that it sells the final matching stock item.

Any servicing or repairs carried out by unauthorised personnel or installation of spare parts not supplied by Draper Tools will invalidate your warranty.

Important: For safety, **ALWAYS** drain and clean the product of any oil, fuel, chemicals or other substances before returning it to Draper Tools or its authorised agent. Store these materials in suitable containers and dispose of them in accordance with local regulations. Draper Tools and its agents cannot be responsible for the disposal of these substances.

At the end of its working life, dispose of the product responsibly and in line with local regulations. Recycle where possible.

Dispose of oil and condensate separately and in accordance with local regulations; **DO NOT** abandon them in the environment.



Draper Tools products are carefully tested and inspected before shipment and are guaranteed to be free from defective materials and workmanship.

Should the tool develop a fault, return the complete tool to your nearest distributor or contact Draper Tools directly. Contact information can be found at the back of this manual.

Proof of purchase must be provided.

If, upon inspection, it is found that the fault occurring is due to defective materials or workmanship, repairs will be carried out free of charge. This warranty period covers parts and labour for 6 months from the date of purchase. Where tools have been hired out, the warranty period covers 90 days from the date of purchase.

This warranty does not apply to any consumable parts, batteries or normal wear and tear, nor does it cover any damage caused by misuse, careless or unsafe handling, alterations, accidents, or repairs attempted or made by any personnel other than the authorised Draper Tools repair agent.

In all cases, to make a claim for faulty workmanship or materials within the standard warranty period, please contact or return the product to the place of purchase. Proof of purchase may be required.

If the place of purchase is no longer trading or if you experience any difficulties with your warranty, please contact Customer Services with the product details and your proof of purchase. Contact details can be found at the back of this manual.

If the tool is not covered by the terms of this warranty, repairs and carriage charges will be quoted and charged accordingly.

This warranty supersedes any other guarantees expressed or implied and variations of its terms are not authorised.

Your Draper Tools guarantee is not effective until you can produce, upon request, a dated receipt or invoice to verify your purchase within the guarantee period.

Please note that this warranty is an additional benefit and does not affect your statutory rights.

Draper Tools Limited

11. Explanation of Symbols



Read the instruction manual



Warning!



Do not abandon in the environment



Wear suitable eye protection and a dust mask



Wear protective gloves



Wear ear defenders



Keep long hair tied back



Backing plate diameter



No load speed



Air inlet



Min. hose size



Max. air pressure



Max. air pressure



Average air consumption



Average air consumption



Product weight (bare)



UK Conformity Assessed



European Conformity

Contact Details

Draper Tools

Draper Tools Limited
Hursley Road
Chandler's Ford
Eastleigh
Hampshire
SO53 1YF
UK

Website: drapertools.com

Email: sales@drapertools.com

Product Helpline: +44 (0) 23 8049 4344

Telephone Sales Desk: +44 (0) 23 8049 4333

General Enquiries: +44 (0) 23 8026 6355

General Fax: +44 (0) 23 8026 0784

Delta International

Delta International BV
Oude Graaf 8
6002 NL
Weert
Netherlands

Please contact the Draper Tools Product Helpline for repair and servicing enquiries.