

EN

Original Instructions
Version 1

DRAPER[®]

GRAVITY FEED
**SPRAY
GUN**

09708, 09709



UK
CA **CE**

These are the original product instructions. This document is part of the product; retain it for the life of the product, passing it on to subsequent holders. Read this manual in full before attempting to assemble, operate or maintain this product.

This Draper Tools manual describes the purpose of the product and contains all the necessary information to ensure its correct and safe use. Following all the instructions and guidance in this manual will ensure the safety of both the product and the operator and increase the lifespan of the product.

All photographs and drawings within this manual are supplied by Draper Tools to help illustrate correct operation of the product.

Every effort has been made to ensure the information contained in this manual is accurate. However, Draper Tools reserves the right to amend this document without prior warning. Always use the latest version of the product manual.

1.1 Product Reference

User Manual for: HVLP Air Spray Gun with Gravity Fed Hopper, 100ml

Stock No: 09708, 09709

Part No: GSG5-100, GSG5-COMP-100

1.2 Revisions

Version 1: January 2010
First release

Version 2: October 2022
Separated from combined manual
General formatting and content updates

As our manuals are continually updated, always ensure that the latest version is used.

Please visit drapertools.com/manuals for the latest version of this manual and the associated parts list, if applicable.

1.3 Understanding the Safety Content of This Manual



WARNING! – Situations or actions that may result in personal injury or death.



CAUTION! – Situations or actions that may result in damage to the product or surroundings.

Important: – Information or instructions of particular importance.

1.4 Copyright © Notice

Copyright © Draper Tools Limited.

Permission is granted to reproduce this manual for personal and educational use **ONLY**. Commercial copying, redistribution, hiring or lending is strictly prohibited.

No part of this manual may be stored in a retrieval system or transmitted in any other form or means without written permission from Draper Tools Limited.

In all cases, this copyright notice must remain intact.

1. Preface	2
1.1 Product Reference	2
1.2 Revisions	2
1.3 Understanding the Safety Content of This Manual	2
1.4 Copyright © Notice	2
2. Contents	3
3. Warranty	4
4. Product Introduction	5
4.1 Scope	5
4.2 Specification	5
5. Health and Safety Information	6
5.1 General Health and Safety Precautions	6
5.2 Additional Safety Instructions for Air Tools	6
6. Identification and Unpacking	8
6.1 Product Overview	8
6.2 What's in the Box?	9
6.3 Packaging	9
7. Preparation Instructions	10
7.1 Preparing the Air Supply for Use	10
7.2 Cleaning the Product and Accessories Before First Use	10
7.3 Assembly, Filling and Connection	10
8. Operating Instructions	12
8.1 The Air Control Dial	12
8.2 The Fluid Control Dial	12
8.3 The Spray Control Dial	12
8.4 The Air Cap	12
8.5 The Trigger	13
8.6 Notes on Use	13
9. Maintenance and Troubleshooting	14
9.1 General Maintenance	14
9.2 Cleaning the Spray Gun	14
9.3 Storing the Product	15
9.4 Troubleshooting	15
10. Spares, Returns and Disposal	17
11. Explanation of Symbols	18

Draper Tools products are carefully tested and inspected before shipment and are guaranteed to be free from defective materials and workmanship.

Should the tool develop a fault, return the complete tool to your nearest distributor or contact Draper Tools directly. Contact information can be found at the back of this manual.

Proof of purchase must be provided.

If, upon inspection, it is found that the fault occurring is due to defective materials or workmanship, repairs will be carried out free of charge. This warranty period covers parts and labour for six months from the date of purchase. Where tools have been hired out, the warranty period covers 90 days from the date of purchase.

This warranty does not apply to any consumable parts, batteries or normal wear and tear, nor does it cover any damage caused by misuse, careless or unsafe handling, alterations, accidents, or repairs attempted or made by any personnel other than the authorised Draper Tools repair agent.

In all cases, to make a claim for faulty workmanship or materials within the standard warranty period, please contact or return the product to the place of purchase. Proof of purchase may be required.

If the place of purchase is no longer trading or if you experience any difficulties with your warranty, please contact Customer Services with the product details and your proof of purchase. Contact details can be found at the back of this manual.

If the tool is not covered by the terms of this warranty, repairs and carriage charges will be quoted and charged accordingly.

This warranty supersedes any other guarantees expressed or implied and variations of its terms are not authorised.

Your Draper Tools guarantee is not effective until you can produce, upon request, a dated receipt or invoice to verify your purchase within the guarantee period.

Please note that this warranty is an additional benefit and does not affect your statutory rights.

Draper Tools Limited

4.1 Scope

This product is a gravity-fed high velocity, low pressure (HVLV) spray paint gun for use with compressed air systems and is suitable for use with all types of paint, particularly water-based paints. HVLV spray guns deliver more fluid at lower pressures and are designed to provide a finer finish than other types of spray gun.

Part of our core range, this product is suitable for regular use by enthusiasts and tradespersons alike.



WARNING! This product is not a toy and must be respected.

Read this manual in full before attempting to assemble, operate or maintain the product, and retain it for later use.

4.2 Specification



Stock No.	09708	09709
Part No.	GSG5-100	GSG5-COMP-100
Nozzle size:	1.0mm	1.0mm
Cup capacity:	100ml	100ml
Operating air pressure:	1.4–2.0bar (20–30psi)	1.4–2.0bar (20–30psi)
Max. air pressure:	2.0bar (30psi)	2.0bar (30psi)
Average. air consumption:	57–142L/min	57–142L/min
Air inlet:	1/4" BSP	1/4" BSP
Fluid delivery rate:	50–80ml/min	50–80ml/min
Sound pressure level:	67dB(A)	71dB(A)
Sound power level:	78dB(A)	82dB(A)
Vibration level:	<2.5m/s ²	<2.5m/s ²
Net weight:	0.34kg	0.248kg

Important: Read all the Health and Safety instructions before attempting to operate, maintain or repair this product. Non-compliance with these instructions may result in injury or damage to the user or the product.

5.1 General Health and Safety Precautions

- Only authorised personnel who have carefully read and understood this manual may operate, adjust and repair this product.
- Observe all standard safety precautions and good practices when working with air tools.
- Always wear adequate eye protection and a face mask when using this product.
 - Some products suitable for use with this product may contain chemicals or toxic components.
 - Avoid inhalation or contact with materials used with this product.
 - If contact occurs, seek medical advice as soon as possible.
- Wear ear defenders and protective gloves while using this product.
- Keep your work environment clear and well-lit, with bystanders at a safe distance.
- Use this product **ONLY** in well-ventilated areas to avoid the build-up of fumes and allow paint particles to disperse.
- Keep out of reach of children.
- Before every use, inspect the tools for missing, broken, loose or corroded parts.
Important: DO NOT use this product if it is damaged in any way. Contact Draper Tools to discuss repair and replacement options.
- Ensure that all accessories and attachments are securely tightened before use.
- Use the product only in the manner instructed in this manual.
- **DO NOT** modify this product in any way.
- **ONLY** use spare parts supplied by Draper Tools.
- Stay alert at all times; **DO NOT** use this product while tired or under the influence of alcohol, drugs or other medication.

5.2 Additional Safety Instructions for Air Tools

- Compressed air can cause severe injury.
 - **ALWAYS** turn off and disconnect the air supply before making any adjustments to the product or leaving it unattended.
 - **NEVER** direct this product towards yourself or others.
 - Ensure that compressed air is not blocked by or in contact with any part of your body.
- **ONLY** use clean, dry and regulated compressed air.
 **WARNING! NEVER use oxygen, combustible gases or other bottled gases as a supply for this product. Use of these substances may cause the product to explode.**
- Draper Tools recommends the use of a whip hose between the tool and the air supply to reduce vibration.
 **CAUTION! Whipping hoses can cause severe injury. Always check for and replace damaged or loose hoses and fittings.**
- Ensure that the product is compatible with the air supply before use.
- Ensure all connections are securely tightened.
- **DO NOT** exceed the maximum stated air pressure.
 - The pressure of the connected air supply **MUST NOT** exceed more than 10% of the rated pressure of the product.
- **DO NOT** obstruct the ability of the trigger to release once depressed.
- **NEVER** carry the tool by the air line.
- Some parts of the spray gun may become hot during use.
 - Allow the nozzle and paint cup to cool after use before handling or adjusting them.
- **NEVER** spray flammable substances near open flames or sources of heat and ignition.
 - **DO NOT** smoke in the vicinity of this product.
- **DO NOT** use this tool in temperatures that do not fall within 0–40°C.



WARNING! The use of solvents that contain halogenated hydrocarbons in pressurised systems with aluminium or galvanised parts may cause chemical reactions that result in an explosion. This product contains components that will be affected by the presence of halogenated hydrocarbons.

DO NOT use halogenated hydrocarbons with this product. Many halogenated hydrocarbons can be identified by the presence of reductions of fluorine (e.g. fluoro-), bromine (e.g. bromo-), chlorine (e.g. chloro-) or iodine (e.g. iodo-).

6.1 Product Overview

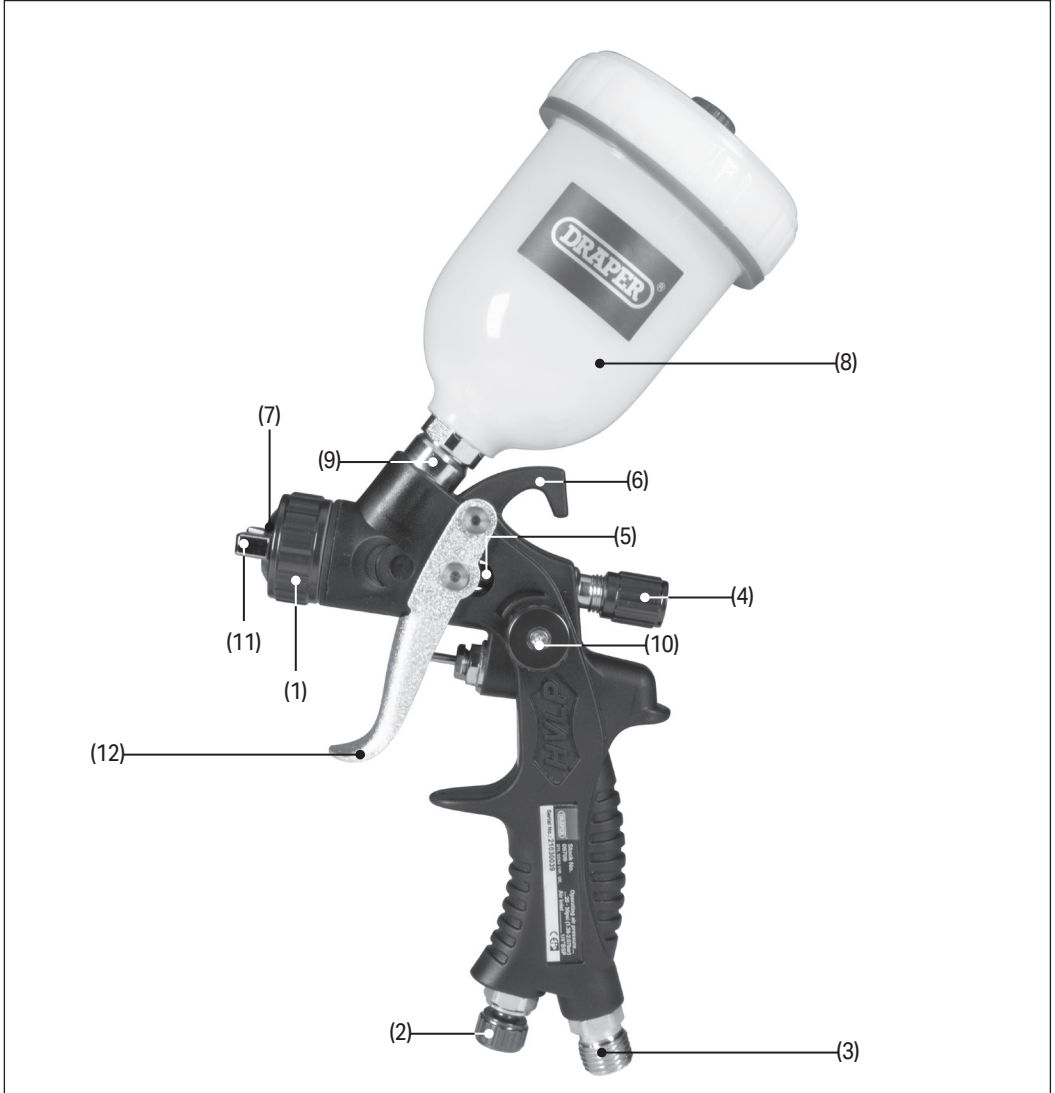

- | | |
|------------------------|------------------------------|
| (1) Air cap | (7) Nozzle |
| (2) Air control dial | (8) Paint cup |
| (3) Air line inlet | (9) Paint inlet |
| (4) Fluid control dial | (10) Spray control dial |
| (5) Fluid needle | (11) Spray direction control |
| (6) Hanging hook | (12) Trigger |

6. Identification and Unpacking

6.2 What's in the Box?

Carefully remove the product from the packaging and examine it for any signs of damage that may have occurred during shipment.

Before assembling the product, lay the contents out and check them against the parts shown below. If any part is damaged or missing, do not attempt to use the product. Please contact the Draper Helpline; contact details can be found at the back of this manual.

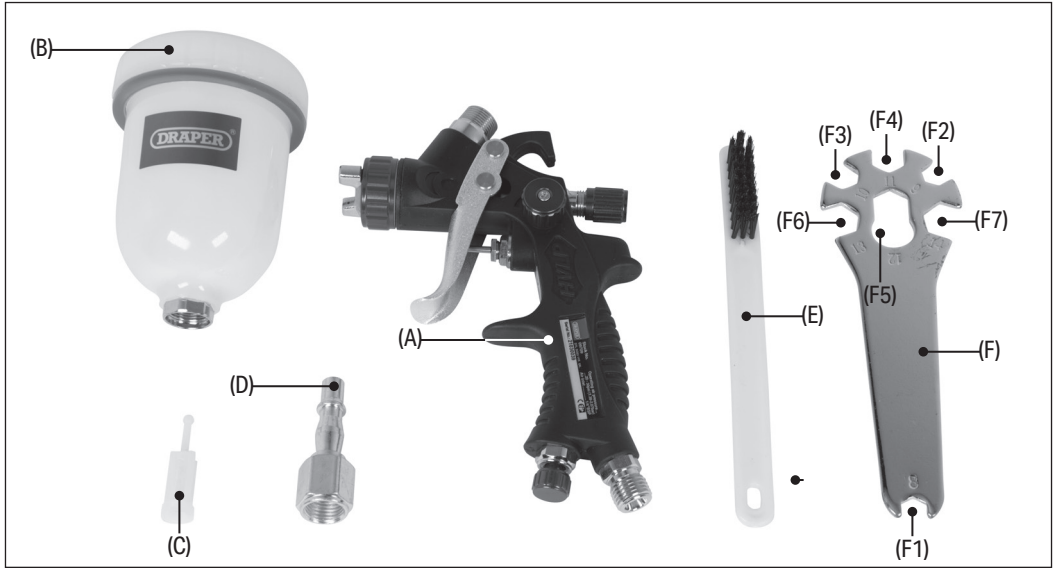

- (A) 1 x Spray gun body
- (B) 1 x 100ml paint cup
- (C) 1 x Paint filter
- (D) 1 x 1/4" BSP air line coupling
- (E) 1 x Brush

- (F) 1 x Spanner tool
 - (F1) 8mm (M5) spanner
 - (F2) 9mm spanner
 - (F3) 10mm (M6) spanner
 - (F4) 11mm (M7) spanner
 - (F5) 12mm ring spanner
 - (F6) 13mm (M8) spanner
 - (F7) 14mm spanner

6.3 Packaging

Keep the product packaging for the duration of the warranty period in case the product needs to be returned for repair.



WARNING! Keep packaging materials out of reach of children. Dispose of packaging correctly and responsibly and in accordance with local regulations.

Please visit drapertools.com for our full range of accessories and consumables.

7.1 Preparing the Air Supply for Use

This air tool operates at a max. pressure of 2bar (30psi).

The compressed air system must be controlled by a combination pressure regulator and moisture filter; this will ensure a constant supply of dry air at all times, provided it is properly maintained.

Important: Always check the machine operating pressure before use.

Water in the compressor tank may cause considerable corrosion to air tools; the compressor should be drained

daily to avoid excessive water in the air supply. Dirty or wet air can significantly shorten the lifespan of the product.

When using an air tool with a hose over 25ft long, Draper Tools recommends increasing the bore of the hose to the next largest available size (i.e. increase 3/8" to 1/2"). This will ensure adequate pressure and volume of air to power the tool.

CAUTION! DO NOT lubricate the air line when using paint spray guns. Ensure that any oil device has been removed and any residual oil is purged from the system before connecting the spray gun.

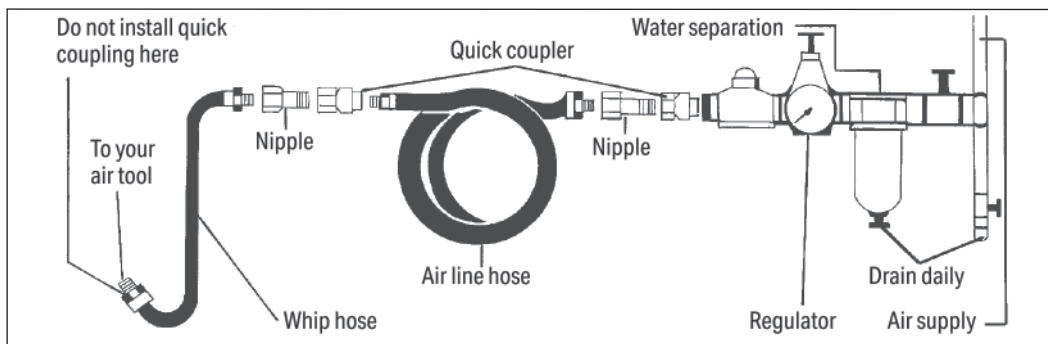

Fig. 1

7.2 Cleaning the Product and Accessories Before First Use

Before first use, the spray gun must be cleaned thoroughly to remove any oil, grease and the protective film applied before shipment.

1. Disassemble the spray gun and immerse all parts and accessories in spray gun cleaning fluid.
2. Soak the parts for a few minutes.
3. Allow the parts to dry and then wipe them clean with a damp cloth.
4. Assemble the spray gun (see 7.3) and half-fill the paint cup (8) with thinners.
Important: DO NOT connect the spray gun to the regulator or air line at this time.
5. Squeeze the trigger (12) to flush the thinners through the spray gun until the paint cup is empty.
6. Immerse and soak the assembled spray gun in the cleaning fluid for a few more minutes.
7. Allow the parts to dry and wipe them clean.

7.3 Assembly, Filling and Connection

Important: Draper Tools recommends using a 1/4" BSP thread whip hose (Stock No. 54438) to connect the spray gun to an air line in order to reduce vibration.

1. Insert the paint filter (C) fully into the spray gun paint inlet (9) with the needle pointing downwards.

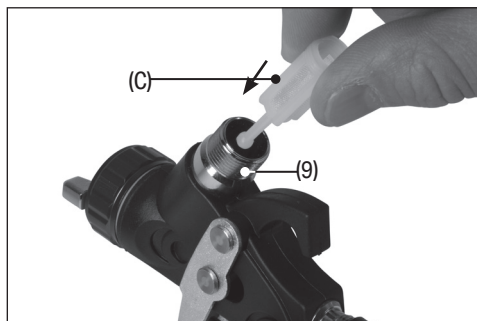

Fig. 2

7. Preparation Instructions

2. Attach the paint cup (8) to the spray gun inlet.

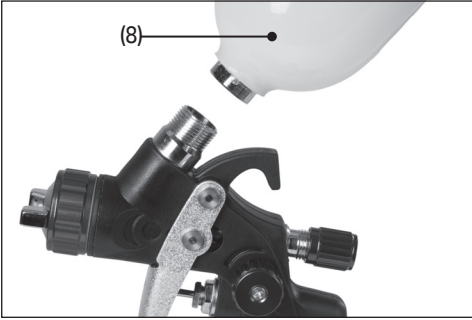

Fig. 3

3. Rotate the fluid control dial (4) clockwise as far as possible to close the fluid valve.

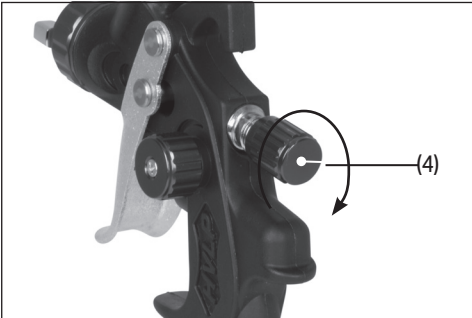

Fig. 4

4. Wrap a length of PTFE tape around the spray gun air line inlet (3).

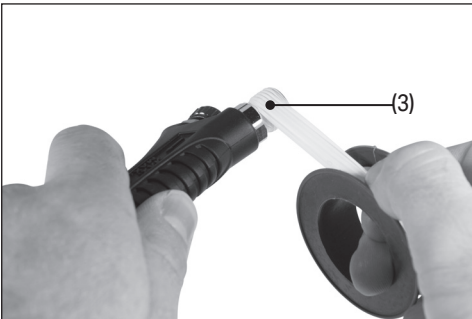

Fig. 5

Important: For a more secure seal, the PTFE tape should be wrapped in the opposite direction to the thread.

5. Screw the 1/4" air line coupling (D) onto the spray gun air inlet.

Important: If using a whip hose, attach a parallel union nut (Stock No. 25823) instead of the air line coupling. Wrap a length of PTFE tape around the whip hose outlet thread and attach it to the parallel union nut.

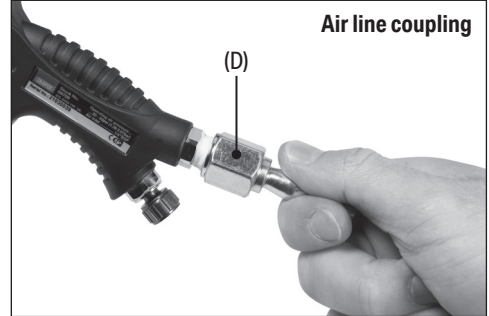

Fig. 6

6. Connect the air line to the air line coupling or whip hose.
7. Unscrew the paint cup lid and pour in the required quantity of paint.
Important: ALWAYS ensure that the paint is mixed and thinned to the manufacturer's recommendations.
8. Pressurise the air line when you are ready to begin.

Important: Before using this product, read and understand all the safety instructions listed in this manual. **DO NOT** make any adjustments to the spray gun while the trigger is depressed.

8.1 The Air Control Dial

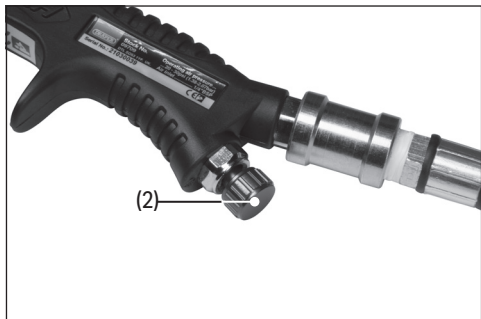

Fig. 7

The air pressure can be fine-tuned by adjusting the air control dial (2) on the spray gun. This is used to make minor adjustments to the air flow after the required air pressure has been set by the air line regulator.

- **To increase the airflow:** Rotate the dial clockwise.
- **To decrease the airflow:** Rotate the dial anticlockwise.

Important: The air control dial should typically remain in the fully open position to allow the full flow of air into the spray gun, but it may be used to make minor adjustments for specific operations. The dial will click when it has been wound to its fully open position.

8.2 The Fluid Control Dial

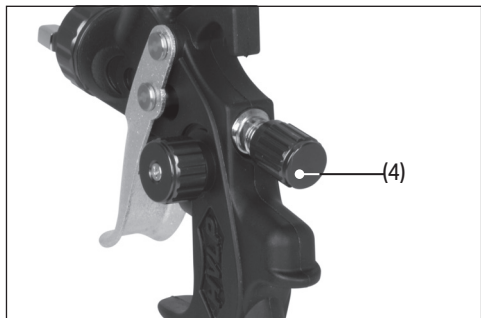

Fig. 8

The fluid control dial (4) adjusts the amount of paint that is released into the air flow and the density of the spray when the trigger is fully depressed:

- **To increase the paint quantity and density:**
Rotate the nozzle regulator anticlockwise.
 - The paint quantity should be increased when the spray gun is positioned further from the surface or when the paint mixture has a higher viscosity.
- **To decrease the paint quantity and density:**
Rotate the nozzle regulator clockwise.
 - The paint quantity should be decreased when the spray gun is positioned closer to the surface or when the paint mixture has a lower viscosity.

8.3 The Spray Control Dial



Fig. 9

The spray control dial (10) adjusts the shape of the paint jet released from the nozzle. The spray control dial can be rotated more than 360°.

- **Fuller, flatter pattern:** Rotate the dial clockwise.
- **Narrower, rounder pattern:** Rotate the dial anticlockwise.

8.4 The Air Cap

The air cap (1) has three types of opening that affect the pattern of the fluid spray:

- A hole for the nozzle head from which the fluid is dispersed (13).
- Atomising air holes (14) that break the fluid into a fine spray.
- Air horn holes (15) that shape the spray pattern as required.

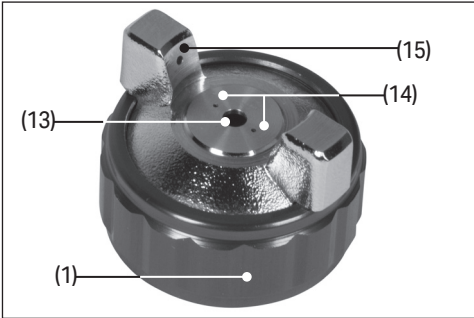

Fig. 10

Once the spray pattern has been set using the control dial, rotate the air cap to change the orientation of the jet.

Important: ALWAYS ensure that the air cap remains tightly secured after adjusting its orientation.

8.5 The Trigger

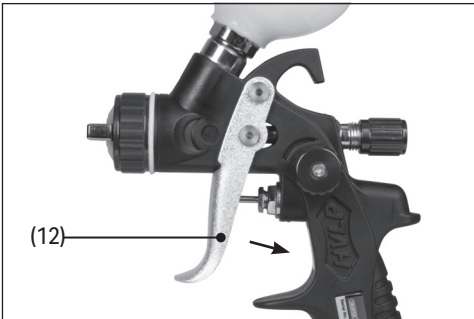

Fig. 11

Paint is released from the spray gun by squeezing the trigger (12):

1. First, squeeze the trigger until resistance is met; this opens the air valve.
2. Squeeze the trigger the rest of the way to draw the fluid pin back and release paint from the nozzle.

Important: Draper Tools recommends that you test the spray output on an area of scrap material before working on the genuine surface. Adjust the control dials to produce an even flow in the desired pattern.

ALWAYS release the trigger before making any adjustment to the spray gun.

8.6 Notes on Use

- Keep the spray gun 6–12" away from the surface during operation.
- Start moving the spray gun **BEFORE** squeezing the trigger to prevent a build-up of paint at the starting point.
- Move the spray gun with a smooth motion, keeping it perpendicular to and at a constant distance from the surface at all times.
- **DO NOT** rock or pivot the spray gun as this will deliver uneven coverage of the surface.
- **DO NOT** hold the spray gun in a static position while the trigger is depressed as this will deliver uneven coverage.
- Slightly overlap the movements of the spray gun to ensure an even distribution at the edges of each stroke.
- Use a piece of scrap material at the edges of the area to prevent overspray and protect other surfaces.
- Alter the speed of the movement, the distance from the surface and the fluid control dial setting to adjust the thickness of the paint applied to the surface.
- Release the trigger **BEFORE** completing the spray gun movement at the end of the final stroke to prevent a build-up of paint at the finishing point.

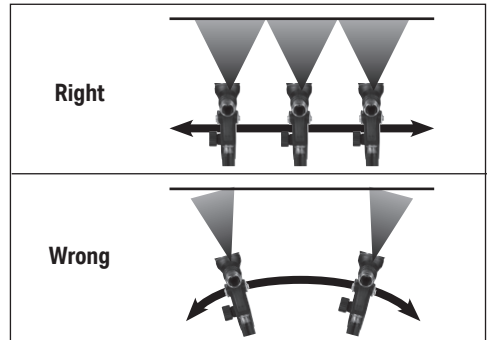

Fig. 12

Important: Read all the Health and Safety information in this manual before attempting to maintain this product. All maintenance should be carried out **ONLY** by authorised and suitably qualified personnel.

! **WARNING! ALWAYS ensure that the tools are disconnected from the air supply and that the air supply is switched off before attempting to adjust or maintain this product.**

9.1 General Maintenance

- Keep the spray guns clean and dry when not in use.
- Protect the product from adverse weather conditions, both when in use and when stored.

! **CAUTION! NEVER lubricate the spray gun or its accessories with oil, grease or any silicone-based product.**

9.2 Cleaning the Spray Gun

Important: **ALWAYS** ensure that the brushes are clean before use on each part of the spray gun. **DO NOT** use sharp objects to clean any openings on the spray gun as this may damage the internal parts.

! **CAUTION! DO NOT soak parts in solvents or cleaning fluids for too long as prolonged exposure may cause damage to the seals and other components.**

1. Use compressed air to clean inside the air line inlet.
2. Clean the paint cup and fluid chamber:
 - a. Remove the paint cup (8) lid and pour any remaining fluid into a suitable container.
 - b. Half-fill the paint cup with an appropriate thinner and replace the lid.
 - c. Squeeze the trigger and spray all the liquid through the tool.
Important: **ALWAYS** spray the cleaning fluid safely into a suitable container.
 - d. Repeat this process if the cleaning fluid is not completely clean when discharged.
Important: If the fluid is not clean after several attempts, remove the paint filter from within the spray gun paint inlet and immerse it in the thinner to ensure that it is clean.
 - e. Wipe the paint cup clean.

3. Clean the air cap and nozzle head:
 - a. Twist the air cap (1) anticlockwise to remove it.

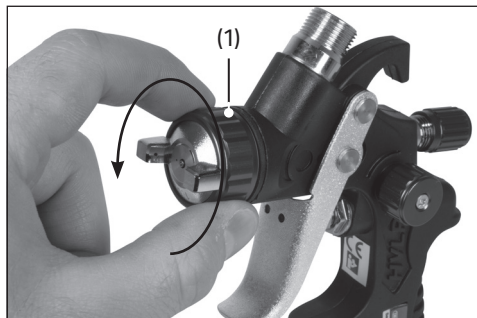

Fig. 13

- b. Use the 8mm spanner (F1) to remove the nozzle head (16).

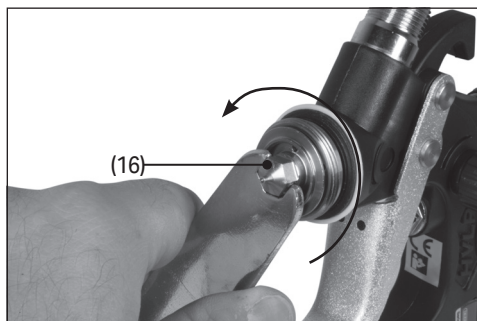

Fig. 14

- c. Soak the parts in a solvent to clear clogged holes or openings, then rinse them clean.
- d. Clean the inside and outside of the air cap and nozzle head using the brush (E).

! **CAUTION! Take great care to avoid damaging the openings in the air cap and nozzle head during cleaning as this will affect the spray pattern.**

4. Clean the fluid needle and chamber:
 - a. Rotate the fluid control dial (4) anticlockwise until it comes away from the spray gun body.

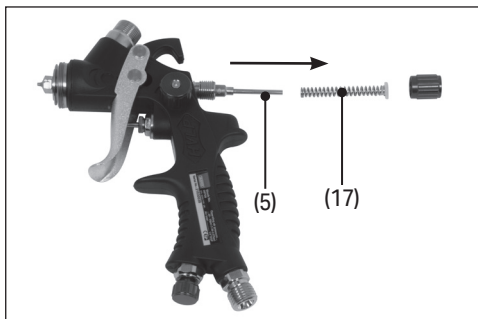

Fig. 15

- b. Remove the spring (17) and the fluid needle (5) from the chamber via the back of the spray gun.
 - c. Soak the parts in the solvent and rinse them clean.
 - d. Clean all parts of the fluid needle using the brush.
5. Soak the spray gun body in the solvent, then rinse it and clean it with the brush.

6. Reassemble the spray gun:
 - a. Reattach the nozzle head.
 - b. Insert the fluid needle point-first into the chamber through the back of the spray gun.
Important: Ensure that the needle point aligns with and passes through the trigger cylinder when it is inserted.
 - c. Pass the spring onto the flat end of the fluid needle and screw the fluid control dial back into place.
 - d. Reattach the air cap and test the trigger to ensure smooth operation.

9.3 Storing the Product

When the spray gun and its accessories are not in use:

- Switch off and disconnect the air line and detach it from the regulator.
- Remove the regulator from the tool.
- Clean the tool thoroughly before storage.
- Store the tool in a clean and dry location, out of the reach of children.

9.4 Troubleshooting

Problem	Possible Cause	Remedy
Paint leaks from the nozzle when not in use.	Dust or dirt around the nozzle opening or fluid needle is preventing an airtight seal with the paint cup.	Clean the fluid needle and nozzle head (see 9.2).
	The nozzle head or fluid needle is damaged.	Replace the nozzle head or fluid needle as appropriate. Contact Draper Tools for repair and replacement options.
The spray gun delivers a curved or one-sided spray pattern.	The openings in the air cap or nozzle are clogged or damaged.	Clean the air cap (see 9.2) and nozzle or replace the parts if necessary. Contact Draper Tools for repair and replacement options.
The spray pattern is too thick.	The fluid viscosity is too high.	Thin the fluid as appropriate.
	The air pressure at the nozzle is too low.	Increase the air pressure and check the tool for leaks or blockages.
	The fluid needle or nozzle head has become worn and the separation between them has increased.	Replace the nozzle head or fluid needle as appropriate. Contact Draper Tools for repair and replacement options.

Problem	Possible Cause	Remedy
The spray pattern is too thin.	The fluid viscosity is too low.	Thicken the fluid as appropriate.
	The air pressure at the nozzle is too high.	Decrease the air pressure and check the tool for blockages.
The spray output splutters or is inconsistent.	The fluid level in the paint cup is too low.	Top up the fluid in the paint cup.
	Air is mixing with the fluid due to a leak or broken seal.	Check the tightness of the paint cup and the fluid needle bolt beside the trigger.
	The fluid needle does not create a seal against the inside of the nozzle head when the trigger is released.	Clean or replace the fluid needle and nozzle head as necessary.
The fluid in the paint cup bubbles or boils.	The paint cup is not sealed or is not tightly attached to the spray gun.	Clean, tighten or replace the paint cup as appropriate.
	The spray gun is being held at an ineffective angle.	Hold the spray gun in a more upright position.
	The openings in the air cap are clogged or damaged.	Clean the air cap (see 9.2) or replace the part if necessary. Contact Draper Tools for repair and replacement options.
The centre of the spray pattern is too narrow or the whole pattern is not wide enough.	The fluid viscosity is not appropriate for the spray gun and must be adjusted.	Increase the fluid viscosity for a thicker centre; decrease the fluid viscosity for a broader pattern.
Air is leaking from the air cap.	The air valve is sticking or bent.	Clean the air valve and replace it if it is bent or damaged. Contact Draper Tools for repair and replacement options.
	The air valve seal or spring is broken.	Replace the parts as necessary. Contact Draper Tools for repair and replacement options.
The tool does not spray the fluid.	The air pressure at the spray gun is too low.	Check and regulate the air pressure accordingly.
	The fluid control dial setting is too low.	Rotate the fluid control dial clockwise to increase the flow.
	The fluid is too viscous.	Thin the fluid as appropriate.
	The fluid level in the paint cup is too low.	Top up the fluid in the paint cup.

10. Spares, Returns and Disposal

For spare parts, servicing, and repair and replacement options, please contact the Draper Tools Product Helpline for details of your nearest authorised agent.

Draper Tools will endeavour to hold any spare parts, if applicable, for seven years from the date that it sells the final matching stock item.

Any servicing or repairs carried out by unauthorised personnel or installation of spare parts not supplied by Draper Tools will invalidate your warranty.

Important: For safety, **ALWAYS** drain and clean the product of any paint, thinners or other substances before returning it to Draper Tools or its authorised agent. Store these materials in suitable containers and dispose of them in accordance with local regulations. Draper Tools and its agents cannot be responsible for the disposal of these substances.

At the end of its working life, dispose of the product responsibly and in line with local regulations. Recycle where possible.

Dispose of paint and used thinners separately and in accordance with local regulations; **DO NOT** abandon them in the environment.



11. Explanation of Symbols



Read the instruction manual



Warning!



Do not abandon in the environment



Wear suitable eye protection and breathing apparatus



Wear ear defenders



Wear protective gloves



Keep out of the reach of children



Fluid delivery rate



Max. operating air pressure (psi)



Max. operating air pressure (bar)



Air inlet diameter



Max. fluid capacity



Machine weight (example)



European conformity



UK Conformity Assessed

Contact Details

Draper Tools

Draper Tools Limited
Hursley Road
Chandler's Ford
Eastleigh
Hampshire
SO53 1YF
UK

Website: drapertools.com

Email: sales@drapertools.com

Product Helpline: +44 (0) 23 8049 4344

Telephone Sales Desk: +44 (0) 23 8049 4333

General Enquiries: +44 (0) 23 8026 6355

General Fax: +44 (0) 23 8026 0784

Delta International

Delta International BV
Oude Graaf 8
6002 NL
Weert
Netherlands

Please contact the Draper Tools Product Helpline for repair and servicing enquiries.