

# TECHNICAL DATA SHEET - Universal Adapter Bracket for Large Flat Panel Screens

**peerless**<sup>®</sup>

MODEL: PLP UN-1



The **Solid Point™ Universal Adapter Bracket** covers over 150 screen models (see screen compatibility chart for list of models) and is compatible with various screen mount styles (**mounts sold separately**). The sliding bracket design allows for compatibility with screens between the ranges of 37" to 50". Security fasteners are included to attach the adapter brackets to the screen. Easy to assemble instructions are provided to ensure that the appropriate hardware is used with the correct screen.

**Features:**

- Covers over 150 screen models ranging from 37" to 50"
- Compatible with several screen mount styles (PLA-1, PS-1, PS-2, PLCM-1, PLCM-1CP, PLT, COL) (**mounts sold separately**)
- Security fasteners included
- Heavy gauge cold rolled steel construction
- Scratch resistant black fused epoxy finish
- Easy to assemble instructions

**Components:**

- Adapter Plate
- Two brackets
- Fasteners

**Dimensions:**

**Weight:**

7.9 lb (3.6 kg)

**Shipping weight:**

11.4 lb (5.2 kg)

**Maximum Load Capacity:**

125 lb (56.7 kg)

**Shipping Carton dimensions:**

L= 29.0 in (737 mm)

W= 21.0 in (533 mm)

H= 1.125 in (29 mm)

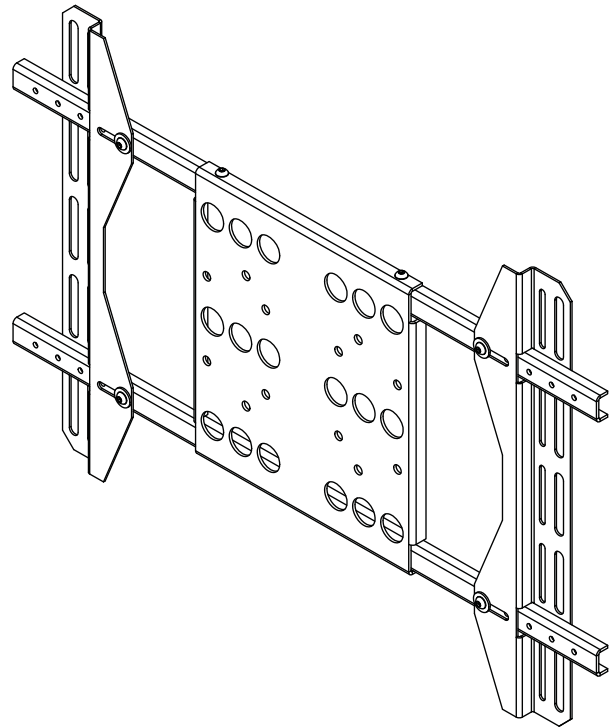

## ARCHITECTS SPECIFICATIONS

The Universal adapter bracket shall be a Peerless model **PLP UN-1** and shall be used in combination with Peerless model \_\_\_\_\_ mount. It shall be constructed of heavy gauge cold rolled steel. It shall mount vertically or horizontally. The finish shall be scratch resistant black fused epoxy. Assembly and installation shall be done according to instructions provided by the manufacturer.

Peerless Industries, Inc.

3215 W. North Ave. Melrose Park, IL 60160  
708-865-8870 800-865-2112 Fax 708-865-2941

[www.peerlessmounts.com](http://www.peerlessmounts.com)

ISSUED: 10-08-02 SHEET NO: 200-9741-13 11-13-10

©2005 Peerless Industries, Inc. All rights reserved.  
Peerless is a registered trademark and Solid•Point is a trademark of Peerless Industries, Inc.  
All other brand and product names are trademarks or registered trademarks of their respective owners.

TECHNICAL DATA SHEET

MODEL: PLP UN-1

