



Compression Sprayers

Welcome and congratulations

for purchasing your new MESTO sprayer.

Thank you for the trust you have shown in our brand.

Your satisfaction with MESTO products and services is very important for us.

Please contact us if your expectations are not met.

You will find our address on the title page of these instructions for use.



Make certain to read the instructions for use before using the device!
Keep the instructions for use in a safe place where they can be easily found.
Particular safety measures are required when working with the device.

Usage

Pressure spraying devices PRIMER 3237P and 3278P are designed for the spraying of deep ground, carpet solvents and other liquids from the building trade. The manufacturer of the spraying agents has to approve that they can be applied with sprayers. The spraying devices must only be used in the exterior or in well aired rooms.

At the time of manufacture, there are no known harmful effects to the device caused by plant protection products approved by the Federal Office of Consumer Protection and Food Safety.



Improper use may result in dangerous injuries and environmental damage.

You should only use other products if harmful effects on the device and endangerment of people and the environment can be excluded. Upon request, we will provide you with a list of active ingredients used in the sprayer.

Not suitable for

- Flammable liquids
- Liquids at temperatures above 30 °C
- Solvents and liquids containing solvents
- Viscous or sticky liquids or liquids that form residues (dyes, greases)
- Use in applications for foodstuffs.

Under no circumstances should you use

- external pressure sources without a MESTO compressed air valve
- for flaming
- for storing and holding liquids
- as an eyewash.

Safety



Only trained, healthy and rested people may work with the device. You should not be under the influence of alcohol, drugs or medication. Children and adolescents must not use the device. Keep the spraying devices out of the reach of children.

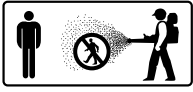

Keep bystanders away during spraying. Take precautions to prevent hazardous substances from being misused.



Wear suitable protective clothing, goggles and respiratory protection when working with hazardous substances.



Never spray on people, animals, electrical devices and lines, into the wind, or into bodies of water.



Avoid ignition sources in the environment if you spray combustible liquids.



Do not leave the device in the sun. Ensure that the device is not heated beyond the maximum operating temperature (→ *Table 1*). Protect the device from frost and ammonia.



Never blow through the nozzles or valves with your mouth.



There is a risk of slipping or tripping on smooth or wet surfaces, snow, ice, on slopes and on uneven terrain.



Repairs and modifications to the tank are not permitted.



Use only MESTO spare parts and accessories. We cannot assume any liability resulting from the use of third-party parts.



When pumping, always observe the pressure gauge to ensure that the recommended spraying pressure is maintained (→ *Table 1 below*). After use and before maintenance work, depressurize the device.



Transport the devices in such a way that they are protected against damage and overturning.

 You will find the illustrations referred to above in the front fold-out pages 3 – 5 of these Instructions for Use.

Scope of delivery

Tank [1] with pump [2], hose [3] with discharge filter [6], shut-off valve [4], instructions for use [5], carrying strap [7] and spray wand [8]. (Fig. 1)

Technical data

Type of device	PRIMER 3237P	PRIMER 3278P
Max. filling amount	5 l (1.1 gal)	8 l (1.8 gal)
Total contents	6.9 l (1.5 gal)	10 l (2.2 gal)
Max. spraying pressure	3 bar (43.5 psi)	
Max. operating temperature	30 °C (86 °F)	40 °C (104 °F)
Weight when empty / Gross weight max.	1.5 / 6.5 kg (3.3 / 14 lb)	3 / 11 kg (6.6 / 24 lb)
Material of tank	polyethylene	
Spray wand	plastic 48 cm (18.9 in)	
Where device is carried	on the side	
Technical residual quantity	< 0.04 l (< 0.01 gal)	
Max. volume flow	1.0 l/min (0.22 gal/min)	
Recoil force	< 5 N	

Table 1

Assembly

1. Fasten the carrying strap [6] on the tank [1] (Fig. 2)
2. Push the hose [3] with the discharge filter [6] into the tank and secure it with the cap nut [9]. (Fig. 3)
3. Push the tube [3] into the shut-off valve [4] and secure it with the cap nut. (Fig. 3)
4. Screw the spray wand [8] onto the shut-off valve [4] (Fig. 3)

Checks

Visual inspection: Are tank [1], pump [2], hose [3], shut-off valve [4] and spray wand [8] with nozzle [16] undamaged? (Figures 1, 3, 18)

 Pay special attention to the connections between the tank – hose and the hose – shut-off valve and to the condition of the pump threading and spray wand.

No leaks: Pump up the empty device to 2 bar (Fig. 10).

- ▶ The pressure must not decrease more than 0.5 bar within 30 minutes.

Function: Pull up the piston pressure gauge [10] (Fig. 4)

- ▶ The pressure must dissipate.

Activate the shut-off valve [4] (Fig. 12)

- ▶ The shut-off valve must open and close.



Have damaged parts or parts that do not work properly repaired immediately by our customer service department or by service partners authorized by us.

Making preparations



Observe the instructions in the section entitled „Safety“.

The device must be in an upright position.

If filling the tank from a water line, ensure that the line or a hose does not project into the tank.

1. Pull up the red button on the piston pressure gauge [10] until all excess pressure is released from the tank (Fig. 4)

2. Press the piston rod with handle [11] down and turn it counterclockwise

▶ The piston rod with handle is locked. (Fig. 5)

3. Unscrew the pump [2] from the tank. (Fig. 6)

 We recommend you mix the spraying liquid in the device or premix it in an external tank: Fill to 1/3 with water, pour in the spraying agent, and then add more water until full.

4. Add the spraying liquid to the tank [1] (Fig. 7)

5. Check the filling level with the scale [12] on the tank. (Fig. 7)

6. Screw the pump [2] into the tank. (Fig. 8)

7. Press the piston rod with handle [11] down and turn it counterclockwise. (Fig. 9)

▶ The piston rod with handle is unlocked. (Fig. 9)

8. Generate the desired pressure (→ Table 2) in the tank (Fig. 10).

 The maximum pressure should not exceed 3 bar (red line on the piston pressure gauge, Fig. 10). If the maximum pressure is exceeded, the safety valve will engage and release the excess pressure.

9. Press the piston rod with handle [11] down and turn it counterclockwise (Fig. 5)

▶ The piston rod with handle is locked.

Spaying



Observe the instructions in the section entitled „Safety“.

Operate the device only while it is vertical or suspended upright and nearly vertical.

Avoid allowing drops of spray to drift onto areas that are not being treated.

Observe the instructions of the spray product manufacturer!

1. Hang the device over your shoulder. (Fig. 11)

 To prevent dripping, hold the spray wand up when first spraying and activate the shut-off valve until no more liquid mixed with air is emerging from the nozzle.

2. Activate the shut-off valve [4] (Fig. 12)

▶ Spraying may now begin.

3. Make certain the optimum spraying pressure is set (→ Table 2) on the piston pressure gauge [10] (Fig. 10).

Spraying pressure	Spraying rate with flat jet nozzle (original equipment)
1.5 bar	0.56 l/min
2.0 bar	0.64 l/min
3.0 bar	0.78 l/min

Table 2. Linear dependence: spraying rate and spraying pressure

4. If the spraying pressure decreases more than 0.5 bar from the optimum level, pump some more.

 If liquid mixed with air emerges from the nozzle, the tank is empty.

After Usage



Observe the instructions in the section entitled „Safety“.
Never leave spraying agent in the device.

1. Pull up the red button on the piston pressure gauge [10] until all excess pressure is released from the tank (*Fig. 4*)
2. Lock the piston rod with handle [11]. (*Fig. 5*)
3. Unscrew the pump [2] from the tank. (*Fig. 6*)
4. Empty and rinse the device with clear water.



Collect and dispose of the residual liquid according to all applicable laws, requirements and regulations. Observe the instructions of the spray product manufacturer!

5. Wipe off the device with a moist cloth.
6. For drying and storing the device, keep the tank [1] and pump [2] separate in a dry place protected from sunlight and freezing temperatures (*Fig. 13*).



Clean the protective equipment and yourself every time after usage.

Care and maintenance



Observe the instructions in the section entitled „Safety“.

After using the device 50 times or at least once a year:

- Unscrew the pump [2] from the tank. (*Fig. 6*)
- Dismantle the pump [2].
 - a) Unlock the piston rod with handle [11].
 - b) Pull the piston rod with handle [11] out of the cylinder tube up to the stop and turn it counterclockwise (*Fig. 14*)
 - c) Disconnect the piston rod with handle [11] and the cylinder tube [2] (*Fig. 14*)
- Grease the diaphragm [14]. (*Fig. 15*)
- Assemble the pump.
 - a) Push the piston rod with handle [11] into the cylinder tube (*Fig. 17*)
 - b) Hold the cylinder tube [2] and strongly press in the guiding plug [15] with your thumb. (*Fig. 17*)
 - c) Pull the piston rod with handle [11] up to the stop down and turn it clockwise (*Fig. 17*)
 - ▶ The guiding plug [15] snaps in.
- Lock the piston rod with handle [11] and screw the pump [2] into the tank [1].
- Clean the nozzle [16] under running water. If required use a needle. (*Fig. 18*)
- Remove the filter [17] between the shut-off valve [4] and spray wand [8], and clean it under running water. (*Fig. 19*)
- Take the hose [3] with the discharge filter [6] out of the tank and clean the discharge filter under running water. (*Fig. 20*)
- Grease the O-rings [13] and [19] (*Fig. 15 and/or 22*)



Observe the legal requirements of your country for accident prevention and check the device in regular intervals. If there are no special rules, we recommend you have the device examined externally by a competent professional every 2 years and subject it to an internal inspection every 5 years. We would be happy to provide you with an inspection schedule in German or English.

Faults



Use only MESTO spare parts and accessories (→ Fig. on page 2).

Fault	Cause	Remedy
No pressure builds up in the device	The pump is not screwed on tightly.	Screw the pump on tightly.
	O-ring [13] on the pump is faulty. (Fig. 16)	Replace the O-ring.
	Diaphragm [14] is defective. (Fig. 16)	Replace the diaphragm.
Liquid flows out of the pump	Valve disc [18] dirty or defective. (Fig. 21)	Clean or replace the valve disc.
No tank pressure indication on the piston pressure gauge, Safety valves blow off too early.	Piston pressure gauge [10] is defective	Have the piston pressure gauge repaired (3237P). Replace the piston pressure gauge (3278P).
The nozzle does not spray even though pressure is present	Nozzle [16] (Fig. 18) or / and filter [17] (Fig. 19) clogged.	Clean the nozzle or / and filter.
	Discharge filter [6] (Fig. 20) blocked.	Clean discharge filter.
The shut-off valve does not close.	O-ring [19] of the pressure bolt [20] is not greased / lubricated. (Fig. 22)	Grease the O-ring of the pressure bolt (dismantle or assemble the pump → section „Care and maintenance“)
Liquid emerges without the lever being activated	Defective pressure bolt [20] or O-ring [19]. (Fig. 22)	Replace the pressure bolt or O-ring.

Warranty

We guarantee that from the time it is first purchased for a period of the legally valid required warranty period (maximum 3 years) this device will not exhibit any material or processing errors. If defects are discovered during the warranty period, MESTO or the distributor in your country will repair the device without charging for the labor or material or (at the discretion of MESTO) replace the device itself or its defective parts. If such defects are discovered, please contact us immediately. We require the invoice or cash register receipt for purchase of the device. The warranty does not include wearing parts (seals, O-rings, diaphragm, etc.) or defects, which have occurred due to improper use or unforeseeable circumstances.

CE Declaration of Conformity

according to EC Machinery Directive 2006/42/EC, Appendix II, No. 1A.

We,

MESTO Spritzenfabrik Ernst Stockburger GmbH

Ludwigsburger Straße 71

D-71691 Freiberg

declare under our sole responsibility that the products pressure spraying devices of the series 3278, 3237 from factory number 1201 or 12A in the version supplied comply with all relevant provisions of the Directive 2006/42/EC.

Furthermore, the device complies with the Directive 97/23/EC for pressure equipment.

Mr. Rolf Rehkugler is authorized to compile the technical documentation.

Freiberg, 15.06.2014



Bernd Stockburger
- Managing Director –

Ersatzteile	Spare Parts	Pièces de Rechange
Reserve-onderdelen	Piezas de repuesto	Pezzi di ricambio
Reservdelar	Varaosat	Reservedeler
Reservedeler	Ανταλλακτικά	Peças sobressalentes
Części zamienne	Запасные части	Varuosi
Rezerves daļas		Atsarginės detalės

PRIMER 3237P, 3237PF, 3278P, 3278PF

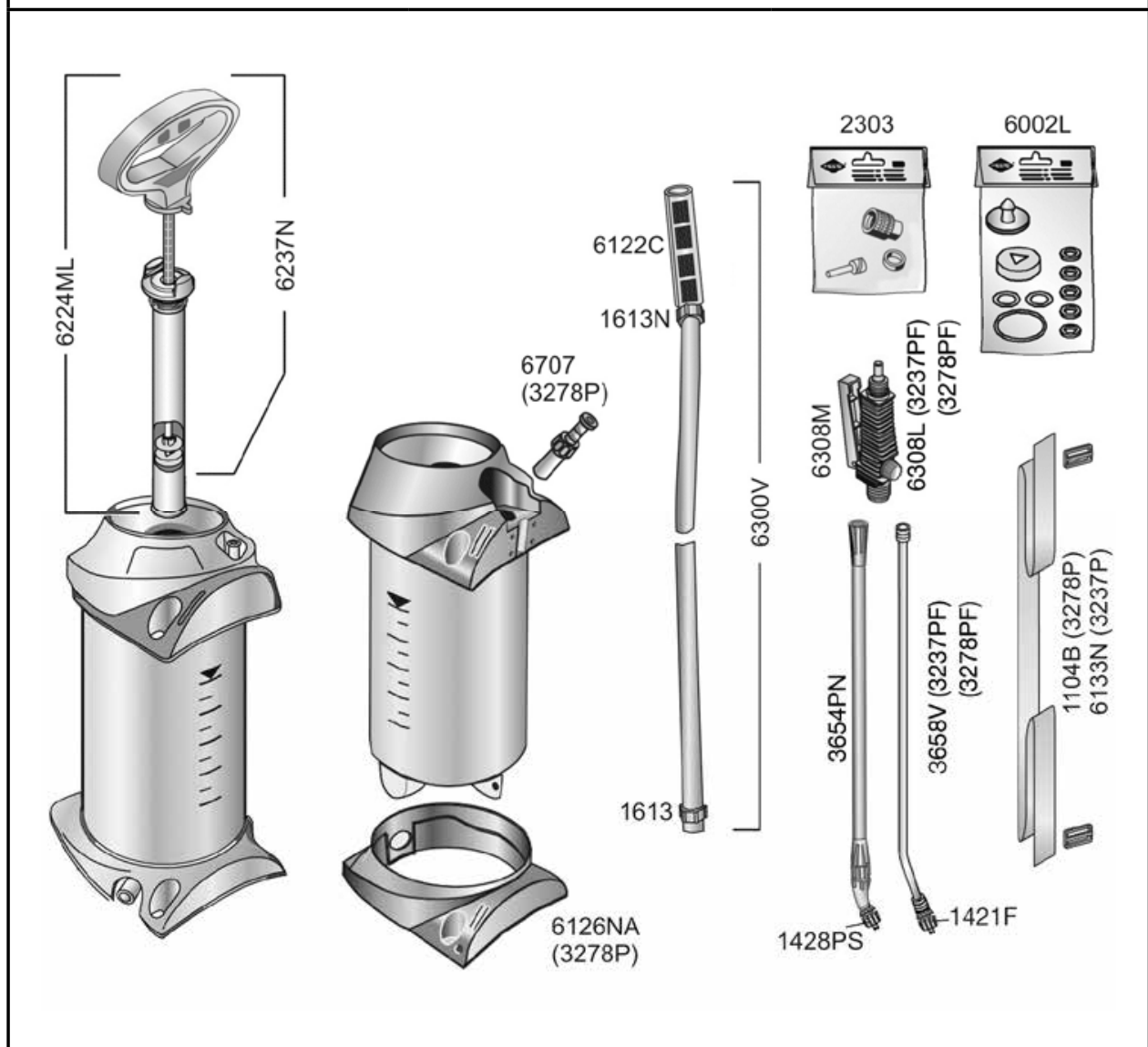

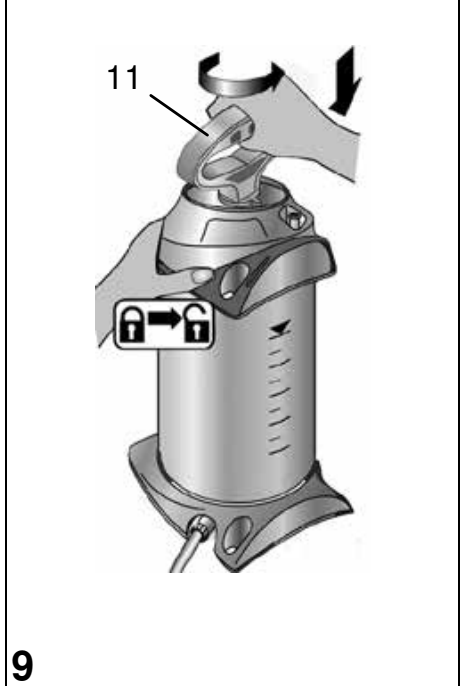
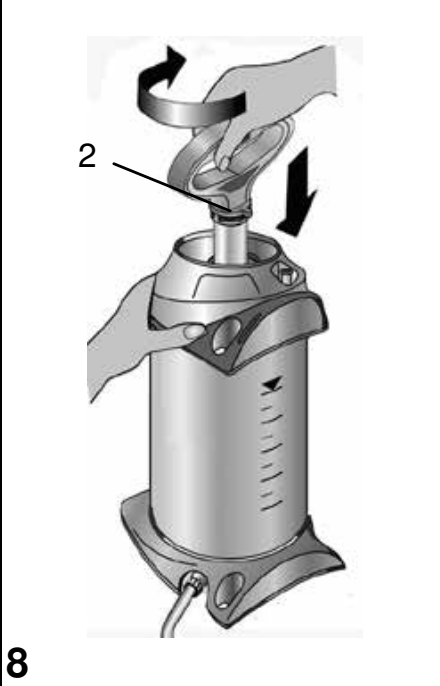
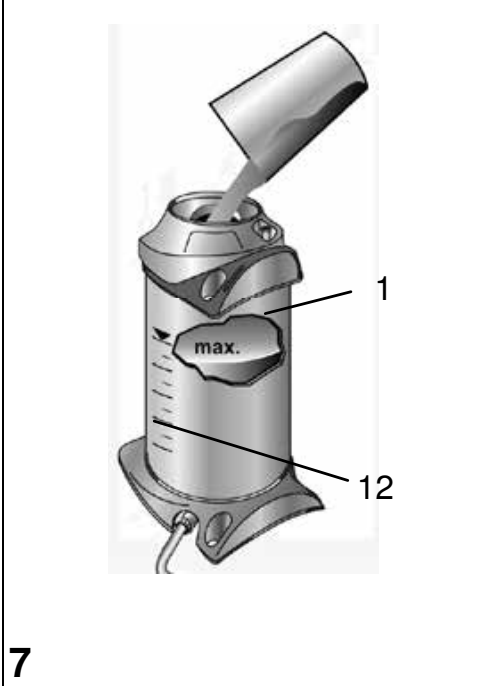
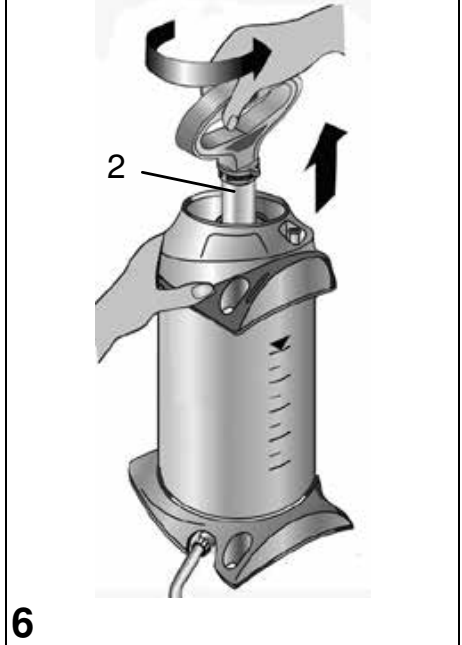
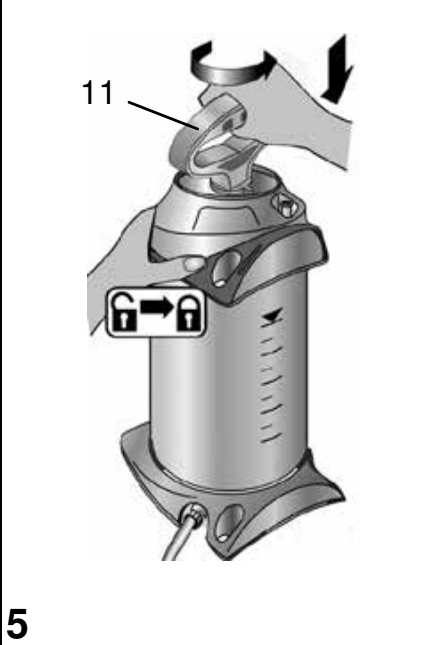
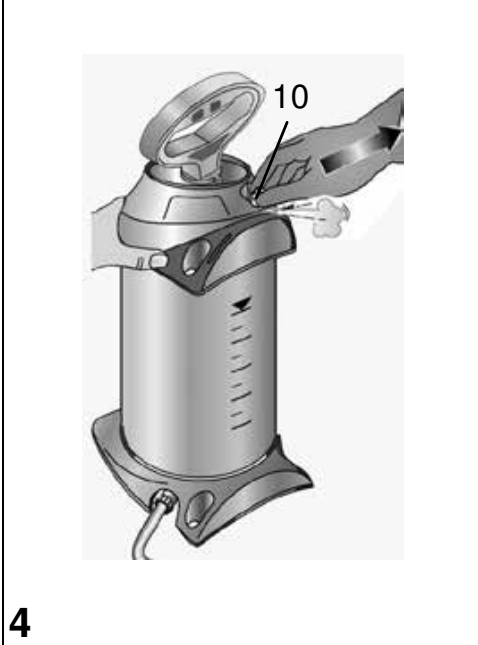
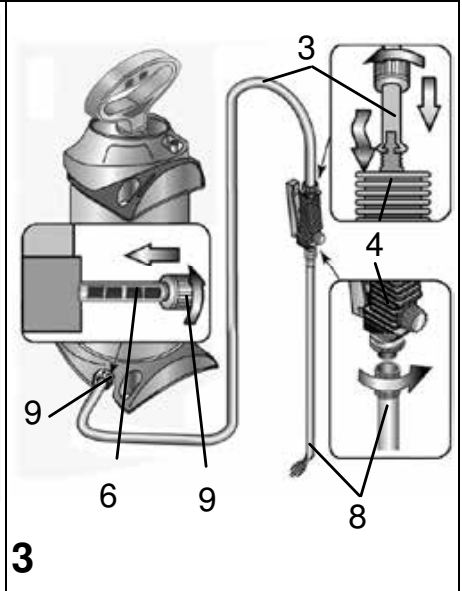
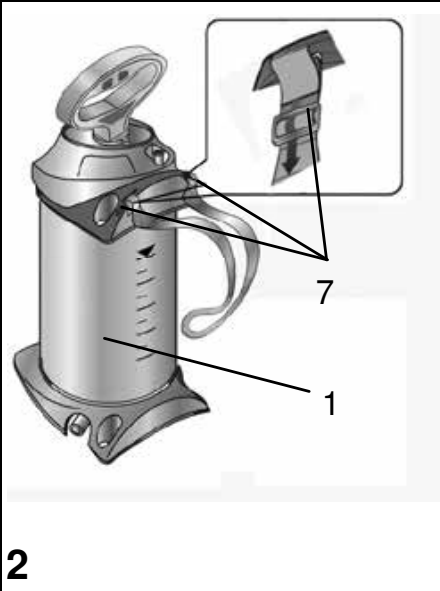

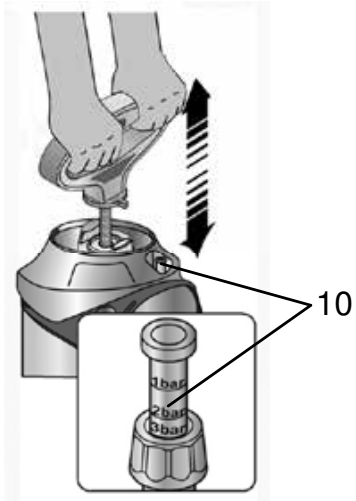

10



11

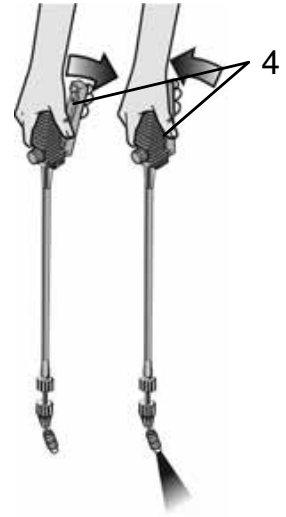

12

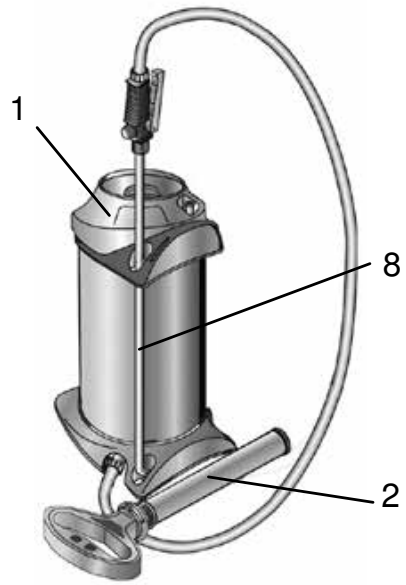

13

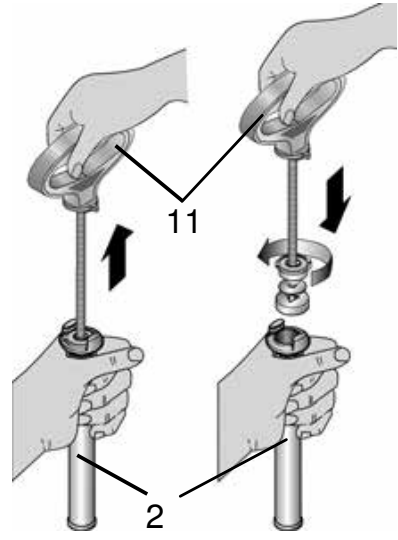

14

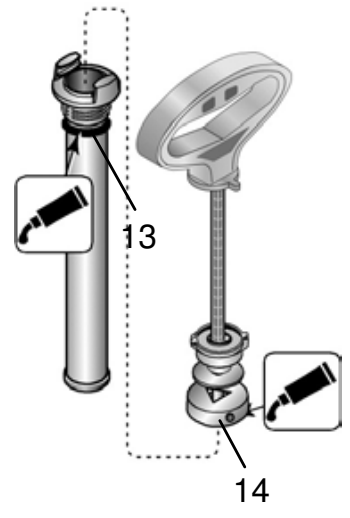

15

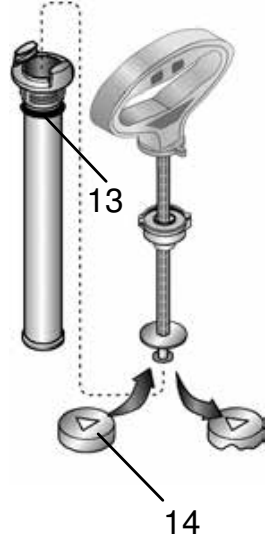

16

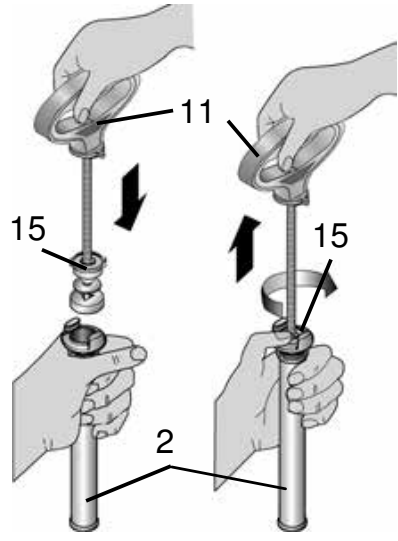

17

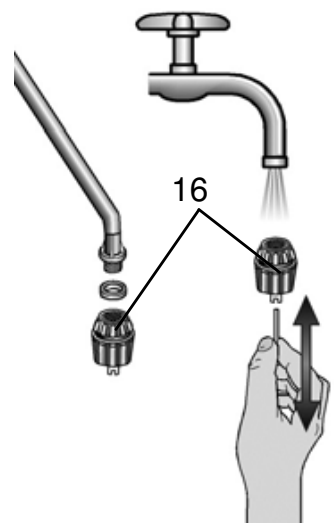

18

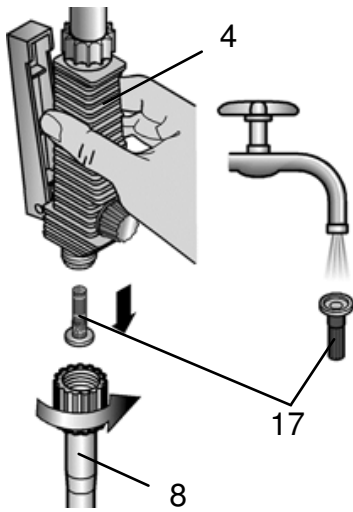

19

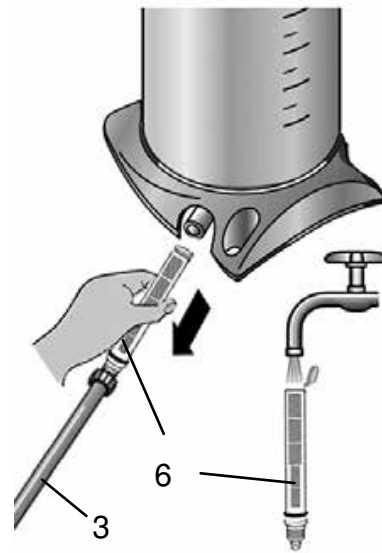

20

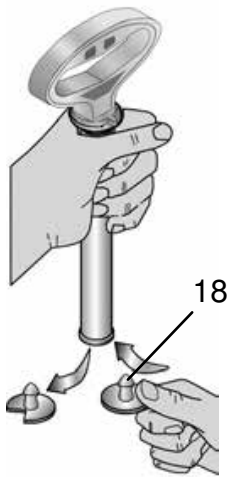

21

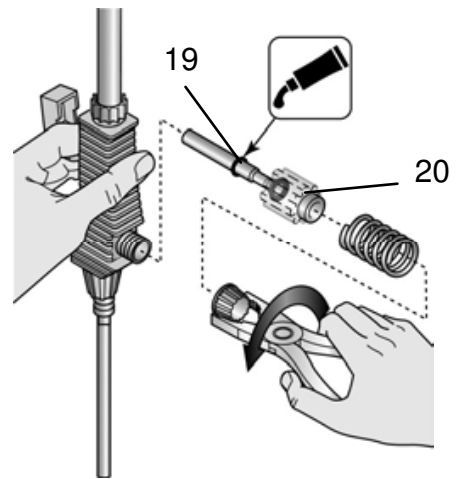

22