

High Pressure Hydraulic Filtration



MATERIALS

Head: Aluminium alloy
Bowl: Steel
Bypass valve : NBR Nitrile (FKM - on request fluoroelastomer)
Seals: NBR Nitrile (FKM - on request fluoroelastomer)
Indicator housing: Brass

PRESSURE (ISO 10771-1:2002)

Max working: 5 MPa (50 bar)
Fatigue test: 0-5 Mpa (0-50 bar) 1 million cycles
Collapse, differential for the filter element (ISO 2941): 1 MPa (10 bar)

BYPASS VALVE

Setting: 350 kPa (3,5 bar) $\pm 10\%$

WORKING TEMPERATURE

From -25° to +110°C

COMPATIBILITY (ISO 2943:1999)

Full with fluids: HH-HL-HM-HV-HTG (according to ISO 6743/4) For fluids different than the above mentioned, please contact our Sales Department.



Return Filters

Installation Drawing

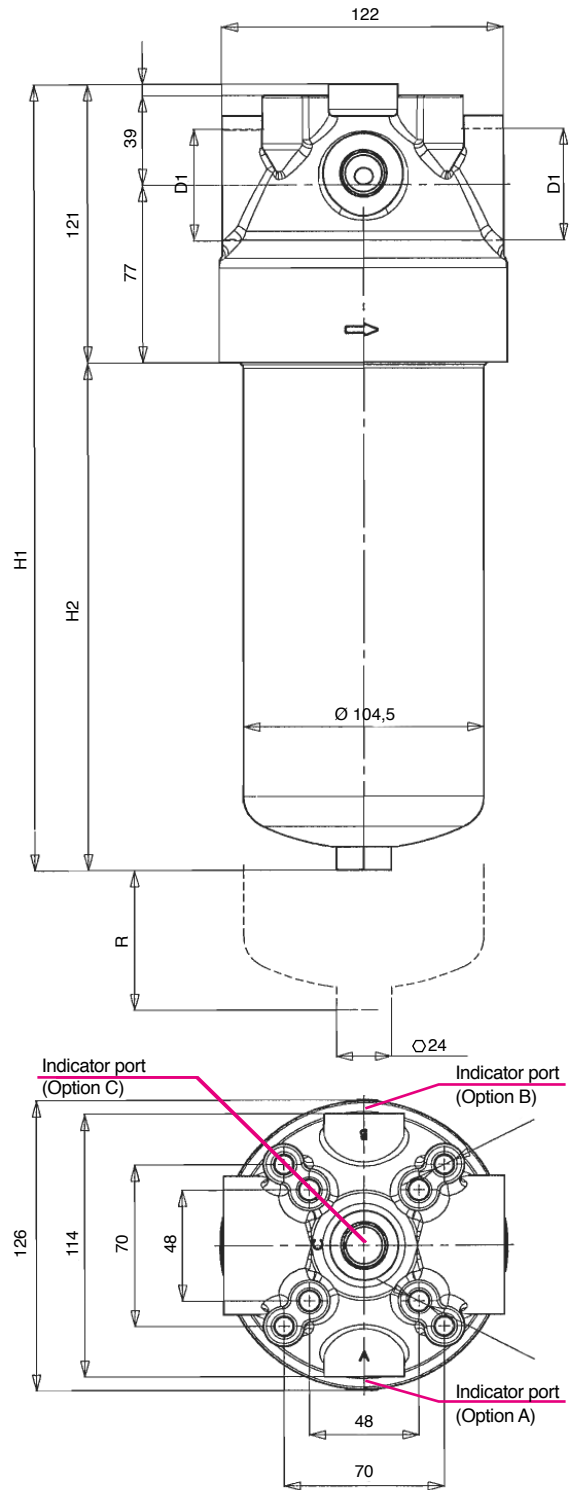
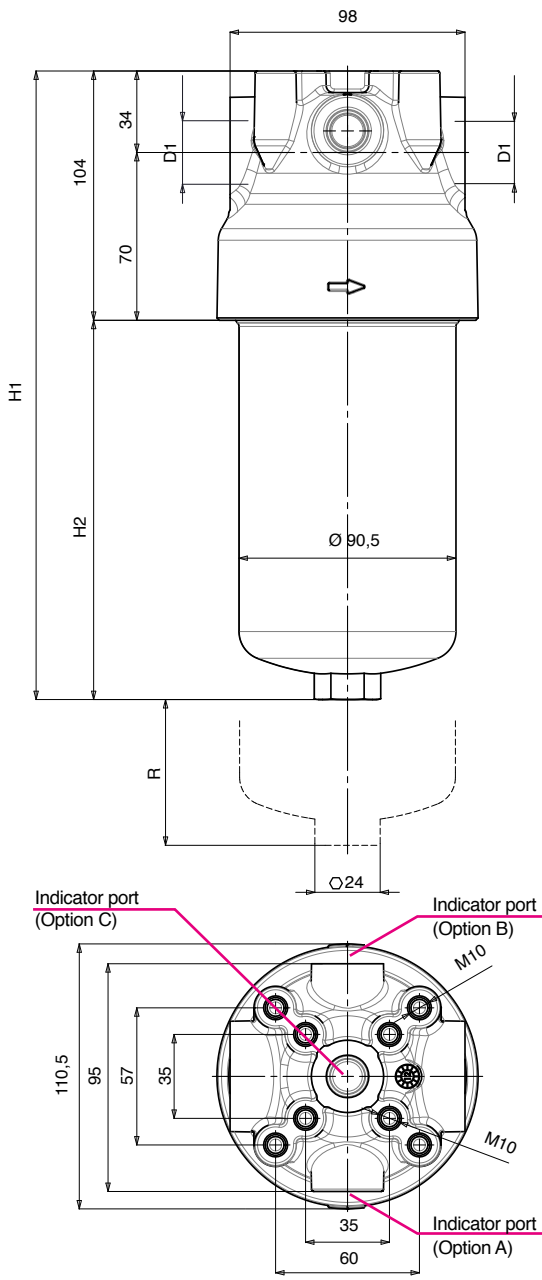

FILTER HOUSING					
	D1	H1	H2	R	kg
FPG20	3/4" - 1"	202	98	70	2,00
FPG21	3/4" - 1"	262	158	70	2,25
FPG22	3/4" - 1"	342	238	70	2,80
FPG31	1" 1/4 - 1" 1/2	341	220	70	3,50

Return Filters

Ordering and Option Chart

		TYPE					
		F = FILTER COMPLETE	F	F	F	F	
		B = FILTER HOUSING	B	B	B	B	ELEMENT E
P	G	FAMILY, NOMINAL SIZE & LENGTH				FAMILY SIZE & LENGTH P G	
		20	21	22	31		
		B PORT TYPE					
		B = BSP	B	B	B	B	
		PORT SIZE (quote D1)					
		06 = 3/4"	06	06	06	-	
		08 = 1"	08	08	08	-	
		10 = 1" 1/4	-	-	-	10	
		12 = 1" 1/2	-	-	-	12	
		BYPASS VALVE					
		W = without	W	W	W	W	
		D = bypass valve 3,5 bar	D	D	D	D	
		SEALS				SEALS	
		N = Nitrile NBR	N	N	N	N	N = NBR
		F = Fluoroelastomer FPM	F	F	F	F	F = FPM
		FILTER MEDIA				FILTER MEDIA	
		FA = fiber 5 μm β >1.000	FA	FA	FA	FA	FA = fiber 5 μm β >1.000
		FB = fiber 7 μm β >1.000	FB	FB	FB	FB	FB = fiber 7 μm β >1.000
		FC = fiber 12 μm β >1.000	FC	FC	FC	FC	FC = fiber 12 μm β >1.000
		FD = fiber 21 μm β >1.000	FD	FD	FD	FD	FD = fiber 21 μm β >1.000
		CC = cellulose 10 μm β >2	CC	CC	CC	CC	CC = cellulose 10 μm β >2
		CD = cellulose 25 μm β >2	CD	CD	CD	CD	CD = cellulose 25 μm β >2
		MC = metal wire mesh 10 μm	MC	MC	MC	MC	MC = metal wire mesh 10 μm
		MD = metal wire mesh 30 μm	MD	MD	MD	MD	MD = metal wire mesh 30 μm
		ME = metal wire mesh 60 μm	ME	ME	ME	ME	ME = metal wire mesh 60 μm
		MF = metal wire mesh 90 μm	MF	MF	MF	MF	MF = metal wire mesh 90 μm
		CLOGGING INDICATORS					
		00 = no indicator port	00	00	00	00	
		03 = indicator port, plugged	03	03	03	03	
		5D = differential 2,5 bar, visual	5D	5D	5D	5D	
		6D = differential 2,5 bar, electrical	6D	6D	6D	6D	
		7D = differential 2,5 bar, electrical + LED	7D	7D	7D	7D	
		76 = differential 2,5 bar, electrical + visual	76	76	76	76	
		T6 = differential 2,5 bar, electrical with Thermostat 30°C	T6	T6	T6	T6	
		ACCESSORIES					
		W = no indicator port	W	W	W	W	
		A = indicator port left side	A	A	A	A	
		B = indicator port right side	B	B	B	B	
		C = indicator port on the top	C	C	C	C	
		X ACCESSORIES					
		X = no accessory available	X	X	X	X	

FILTER ELEMENT						
	A	B	C	Area (cm ²)		
				Media F+	Media C+	Media M+
EPG20	78	30	100	1.300	1.500	1.000
EPG21	78	30	160	2.200	2.550	1.700
EPG22	78	30	240	3.300	3.900	2.600
EPG31	92	40	215	4.700	5.100	3.500

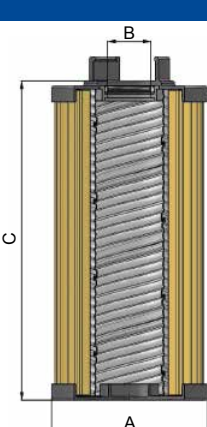

Pressure Filters

Installation Drawing

FLUID SPEED

when selecting the filter size, we suggest to consider also the max recommended fluid speed (in pressure lines normally $5 < v < 10$ m/s).

RECOMMENDED FLOW RATES

Type	Filter Media	Δp 80 kPa (0,8 bar)
FPG 20	FA	55
	FB	70
	FC	80
	FS	85
	FD	90
	CC	105
	CD	115
	MC	130
	MD	130
	ME	150
MF	150	

Type	Filter Media	Δp 80 kPa (0,8 bar)
FPG 21	FA	80
	FB	105
	FC	120
	FS	125
	FD	130
	CC	150
	CD	150
	MC	150
	MD	150
	ME	150
MF	150	

Type	Filter Media	Δp 80 kPa (0,8 bar)
FPG 22	FA	90
	FB	130
	FC	150
	FS	150
	FD	150
	CC	150
	CD	150
	MC	150
	MD	150
	ME	150
MF	150	

Type	Filter Media	Δp 80 kPa (0,8 bar)
FPG 31	FA	260
	FB	270
	FC	310
	FS	340
	FD	360
	CC	400
	CD	400
	MC	400
	MD	400
	ME	400
MF	400	

N.B. All the data have been obtained with mineral oil having a kinematic viscosity 30 cSt and specific gravity 0,9 kg/dm³; for fluids with different features, please consider the factors described in the first part of this catalogue. All the data are obtained from test done at the UFI HYDRAULIC DIVISION Laboratory, according to the specification ISO 3968:2005. In case of discrepancy, please check the contamination level, viscosity and features of the fluid in use.

