

Fire Hose Reels



British Standard Institution Approved Fire Hose Reels

- Approved to B.S. EN 671-1
- Fixed or Swinging
- Manual or Automatic
- 19mm or 25mm Hose
- Full range of hose reel cabinets



General Description

Fire hose reels are manufactured and approved to British Standard (European standard) BS EN 671-1. Compliance to the stringent test required by the above standard guarantees excellent durability and performance. Hose reel side plates are protected with a polyester powder coating that complies to salt spray test requirement which is specified in ISO 9227 for 240 hours.

Fire hose reels have been designed to provide a flow rate of 27 L/min for ¾" and 35 L/min for 1" at 0.2 Mpa.

Fire provides a complete range of hose reels, which includes manual, automatic, swinging and fixed type in ¾" or 1" diameter. Automatic hose reels are available with an internal valve built into the hose reel unit. The internal valve will open fully after three revolutions of the hose reel as the hose is pulled out. The automatic hose reel valve will close when the hose is wound back onto the reel.

Fire hose reels are available with a quick installation mounting bracket which allows installation to be completed by one person.

Technical Data

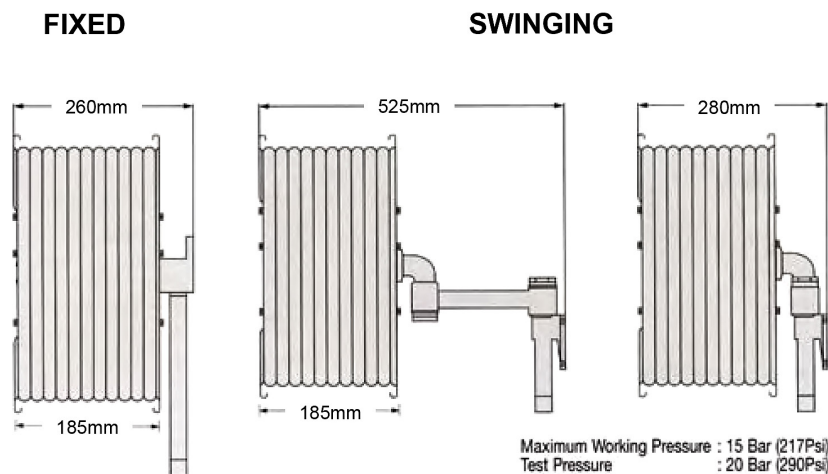

Automatic

Swinging Code	Fixed Code	Drum Capacity	Side Plate Dia.
FHRAAS19	FHRAAF19	¾" Ø x 30m Hose	558 (22")
FHRAAS25	FHRAAF25	1" Ø x 30m Hose	558 (22")

Manual

Swinging Code	Fixed Code	Drum Capacity	Side Plate Dia.
FHRAMS19	FHRAMF19	¾" Ø x 30m Hose	558 (22")
FHRAMS25	FHRAMF25	1" Ø x 30m Hose	558 (22")