

Semi-rotary drives DRRD, twin pistons

FESTO



Festo core product range
Covers 80% of your automation tasks

Worldwide:
Superb:
Easy:

Always in stock
Festo quality at an attractive price
Simplified procurement and warehousing

★ Generally ready for dispatch from the factory within 24 hours
In stock at 13 Service Centres worldwide
More than 2200 products

★ Generally ready for dispatch from the factory within 5 days
Assembled for you at 4 Service Centres worldwide
Up to 6×10^{12} variants per product family

Just look
for the
star!

Semi-rotary drives DRRD, twin pistons

FESTO



Festo core product range
Covers 80% of your automation tasks

Worldwide:
Superb:
Easy:

Always in stock
Festo quality at an attractive price
Simplified procurement and warehousing

★ Generally ready for dispatch from the factory within 24 hours
In stock at 13 Service Centres worldwide
More than 2200 products

★ Generally ready for dispatch from the factory within 5 days
Assembled for you at 4 Service Centres worldwide
Up to 6×10^{12} variants per product family

Just look
for the
star!

Semi-rotary drives DRRD, twin pistons

FESTO



Festo core product range
Covers 80% of your automation tasks

Worldwide:
Superb:
Easy:

Always in stock
Festo quality at an attractive price
Simplified procurement and warehousing

★ Generally ready for dispatch from the factory within 24 hours
In stock at 13 Service Centres worldwide
More than 2200 products

★ Generally ready for dispatch from the factory within 5 days
Assembled for you at 4 Service Centres worldwide
Up to 6×10^{12} variants per product family

Just look
for the
star!

Semi-rotary drives DRRD, twin pistons

FESTO



Festo core product range
Covers 80% of your automation tasks

Worldwide:
Superb:
Easy:

Always in stock
Festo quality at an attractive price
Simplified procurement and warehousing

★ Generally ready for dispatch from the factory within 24 hours
In stock at 13 Service Centres worldwide
More than 2200 products

★ Generally ready for dispatch from the factory within 5 days
Assembled for you at 4 Service Centres worldwide
Up to 6×10^{12} variants per product family

Just look
for the
star!

Characteristics

At a glance

- Rack and pinion principle
- Very high accuracy in the end positions
- Very high load bearing capacity
- Very good axial run-out at the flange shaft
- High mass moments of inertia
- Low backlash and good dynamic response
- Splash-proof design to IP65 based on EN 60529
- Defined interfaces
- Supply port at one end
- Choice of mounting options
- Ideal for use in handling applications

Wide choice of variants

Flange shaft



- Size: 8 ... 63
- Torque: 0.2 ... 112 Nm
- Swivel angle: 0 ... 180°

Drive shaft

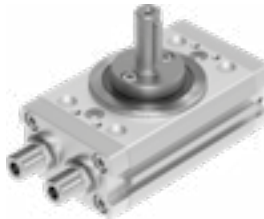

- Size: 12 ... 40
- Torque: 0.8 ... 24.1 Nm
- Swivel angle: 0 ... 180°
- Suitable for ATEX
- Can be ordered as an accessory

Position sensing



- Size: 8 ... 12
 - C-slot for proximity switch SMT/SME-10
- Size: 16 ... 63
 - T-slot for proximity switch SMT/SME-8

External position sensing (sensor mounting)



- Size: 16 ... 63
- Position sensing possible directly at the flange shaft
- Inductive proximity switches SIES can be used in combination with external position sensing

Cushioning



- Size: 12 ... 63
- Five cushioning types available:
 - Elastic cushioning with metal end position (P)
 - Shock absorber (Y9)
 - Shock absorber, hard (Y10)
 - Shock absorber, external (Y12)
 - Shock absorber, soft (Y14)

External cushioning

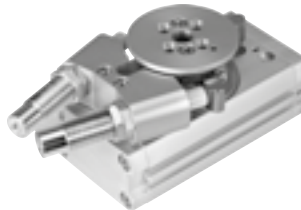

- Size: 12 ... 63
- The full torque can be realised in the end positions in combination with external cushioning

Characteristics

Energy through-feed



- Size: 16 ... 63
- The energy through-feed can be used to transfer electrical signals or compressed air through the hollow shaft. This enables fast and easy supply of the parts connected to the flange (e.g. gripper)

Also suitable for IO-Link signal data transfer.

Intermediate position



- Size: 16 ... 50
- The semi-rotary drive can additionally be positioned at 90° using the intermediate-position module
- The intermediate position can be approached from both directions
- The cushioning for the intermediate position corresponds to the cushioning for the basic drive. Except in the case of cushioning Y12, when shock absorbers Y9 are used

End-position locking

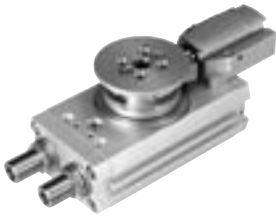

- Size: 16 ... 63
- Mechanical lock in the end positions to prevent unwanted movement in unpressurised condition

Mounting options

Via through-holes

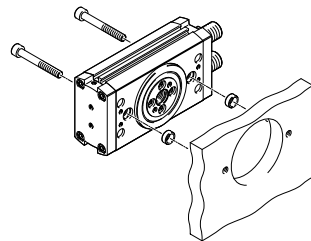
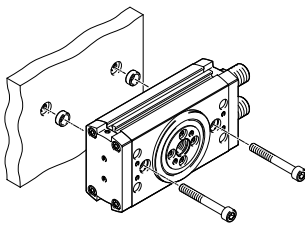

Via thread in the housing profile

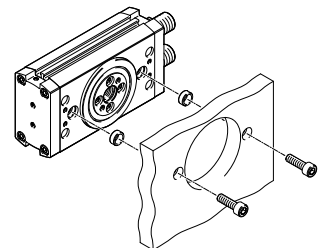
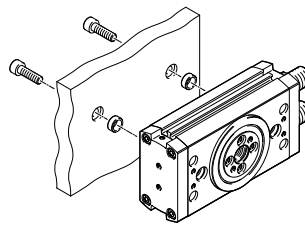

Product range overview

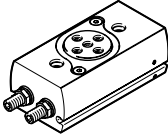
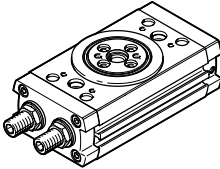
| Function | Version | Size | Swivel angle | Energy through-feed | | | | | | |
|---------------|---|----------|--------------|---------------------|----|------|----|------|----|------|
| | | | | [°] | P2 | P2E2 | P4 | P4E6 | P8 | P8E8 |
| Double-acting | DRRD-8 ... 12 | | | | | | | | | |
| |  | 8 | Max. 200 | - | - | - | - | - | - | - |
| | | 10 | Max. 200 | - | - | - | - | - | - | - |
| | | 12 | Max. 200 | - | - | - | - | - | - | - |
| | DRRD-16 ... 63 | | | | | | | | | |
| |  | 16 | Max. 200 | ■ | ■ | - | - | - | - | - |
| | | 20 | Max. 200 | ■ | ■ | - | - | - | - | - |
| | | 25 | Max. 200 | - | - | ■ | ■ | - | - | - |
| | | 32 | Max. 200 | - | - | ■ | ■ | - | - | - |
| | | 35 | Max. 200 | - | - | ■ | ■ | - | - | - |
| | | 40 | Max. 200 | - | - | - | - | ■ | ■ | - |
| 50 | | Max. 200 | - | - | - | - | ■ | ■ | - | |
| 63 | Max. 200 | - | - | - | - | ■ | ■ | - | | |

Product options

Energy through-feed

- P2 Pneumatic, 2 ducts
- P2E2 Pneumatic, 2 ducts; electric, 2 signals
- P4 Pneumatic, 4 ducts
- P4E6 Pneumatic, 4 ducts; electric, 6 signals
- P8 Pneumatic, 8 ducts
- P8E8 Pneumatic, 8 ducts; electric, 8 signals

Product range overview

| Function | Size | Cushioning | | | | | Position sensing | EU certification | Intermediate position | End-position locking | External sensor mounting | Splash-proof design | → Page/ Internet |
|---------------|-----------------------|------------|----|-----|-----|-----|------------------|------------------|-----------------------|----------------------|--------------------------|---------------------|---------------------|
| | | P | Y9 | Y10 | Y12 | Y14 | | | | | | | |
| Double-acting | DRRD-8 ... 12 | | | | | | | | | | | | |
| | 8 | ■ | - | - | - | - | ■ | - | - | - | - | - | 6 |
| | 10 | ■ | - | - | - | - | ■ | - | - | - | - | | |
| | 12 | ■ | ■ | - | ■ | - | ■ | - | - | - | - | | |
| | DRRD-16 ... 63 | | | | | | | | | | | | |
| | 16 | ■ | ■ | - | ■ | ■ | ■ | ■ | ■ | ■ | ■ | ■ | 20 |
| | 20 | ■ | ■ | - | ■ | ■ | ■ | ■ | ■ | ■ | ■ | ■ | |
| | 25 | ■ | ■ | ■ | ■ | ■ | ■ | ■ | ■ | ■ | ■ | ■ | |
| | 32 | ■ | ■ | - | ■ | ■ | ■ | ■ | ■ | ■ | ■ | ■ | |
| | 35 | ■ | ■ | ■ | ■ | ■ | ■ | ■ | ■ | ■ | ■ | ■ | |
| | 40 | ■ | ■ | ■ | ■ | ■ | ■ | ■ | ■ | ■ | ■ | ■ | |
| | 50 | - | ■ | ■ | ■ | - | ■ | ■ | ■ | ■ | ■ | ■ | |
| | 63 | - | ■ | ■ | ■ | - | ■ | ■ | - | ■ | ■ | ■ | |

Product options

Cushioning

- P Elastic cushioning at both ends
Y9 Linear shock absorber, self-adjusting at both ends, internal
Y10 Linear shock absorber, self-adjusting at both ends, hard, internal
Y12 Linear shock absorber, self-adjusting at both ends, external
Y14 Linear shock absorber, self-adjusting at both ends, soft, internal

System example

System product for handling and assembly technology

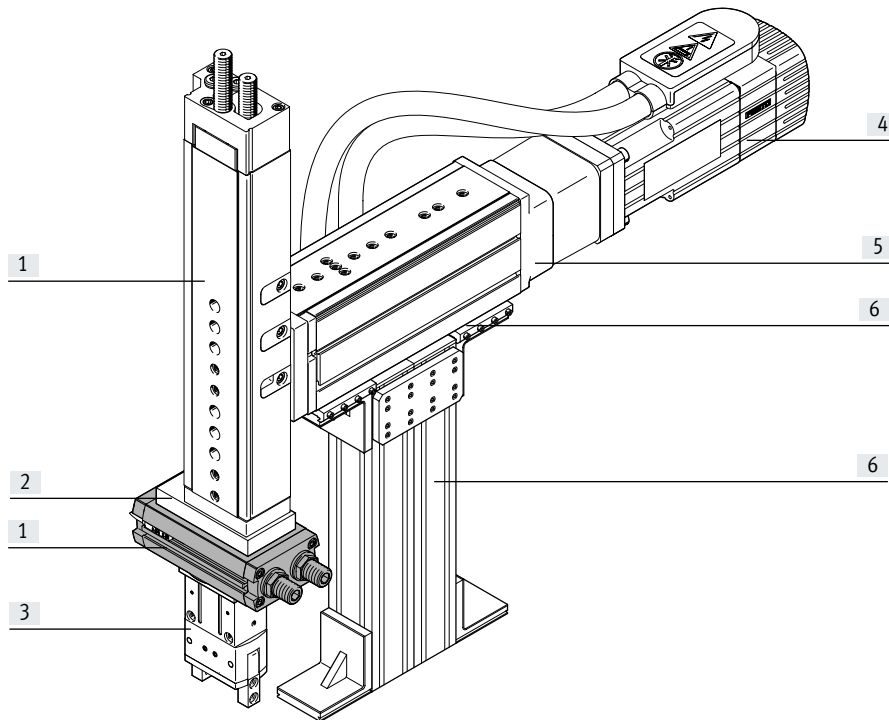

System components and accessories

| | Description | → Page/Internet |
|---------------------------|---|------------------------|
| [1] Drives | Wide range of combinations possible within handling and assembly technology | drive |
| [2] Adapters | For drive/drive and drive/gripper connections | adapter-kit |
| [3] Gripper | Wide range of variation options within handling and assembly technology | gripper |
| [4] Motors | Servo and stepper motors, with or without gear unit | motor |
| [5] Axes | Wide range of combinations possible within handling and assembly technology | axis |
| [6] Basic components | Profiles and profile connections as well as profile/drive connections | basic component |
| - Installation components | For a clear, safe layout of electrical cables and tubing | Installation component |

Type codes

| | | |
|------|----------------------------------|--|
| 001 | Series | |
| DRRD | Semi-rotary drive, double piston | |

| | | |
|-----|------|--|
| 002 | Size | |
| 8 | 8 | |
| 10 | 10 | |
| 12 | 12 | |
| 16 | 16 | |
| 20 | 20 | |
| 25 | 25 | |
| 32 | 32 | |
| 35 | 35 | |
| 40 | 40 | |
| 50 | 50 | |
| 63 | 63 | |

| | | |
|-----|--------------------------|--|
| 003 | Nominal swivel angle [°] | |
| 180 | 180 | |

| | | |
|-----|-----------------------|--|
| 004 | Output shaft | |
| FH | Flanged shaft, hollow | |

| | | |
|------|--|--|
| 005 | Energy through-feed | |
| | None | |
| P2 | Pneumatic, 2 ducts | |
| P2E2 | Pneumatic, 2 ducts and electric, 2 signals | |
| P4 | Pneumatic, 4 ducts | |
| P4E6 | Pneumatic, 4 ducts and electric, 6 signals | |
| P8 | Pneumatic, 8 ducts | |
| P8E8 | Pneumatic, 8 ducts and electrical, 8 signals | |

| | | |
|-----|---|--|
| 006 | Cushioning | |
| P | Elastic cushioning rings/plates on both sides | |
| Y9 | Shock absorber, self-adjusting, linear, at both ends | |
| Y10 | Shock absorber, self-adjusting, linear at both ends, hard | |
| Y12 | Shock absorber, self-adjusting, linear at both ends, external | |
| Y14 | Shock absorber, self-adjusting, linear on both sides, soft | |

| | | |
|-----|----------------------|--|
| 007 | Position sensing | |
| A | For proximity sensor | |

| | | |
|-----|------------------|--|
| 008 | EU certification | |
| | None | |
| EX4 | II 2GD | |

| | | |
|-----|-------------------------|--|
| 009 | Intermediate position | |
| | None | |
| PS1 | 1 intermediate position | |

| | | |
|-----|----------------------|--|
| 010 | End-position locking | |
| | None | |
| E1 | Both sides | |

| | | |
|-----|---------------------------|--|
| 011 | Sensor mounting, external | |
| | None | |
| R | Mounting rail for sensors | |

| | | |
|-----|--------------------------------|--|
| 012 | Version | |
| | Standard | |
| SG | Protected against splash water | |

| | | |
|-----|--------------------------------|--|
| 013 | Operating instructions | |
| | With operating instructions | |
| DN | Without operating instructions | |

Peripherals overview

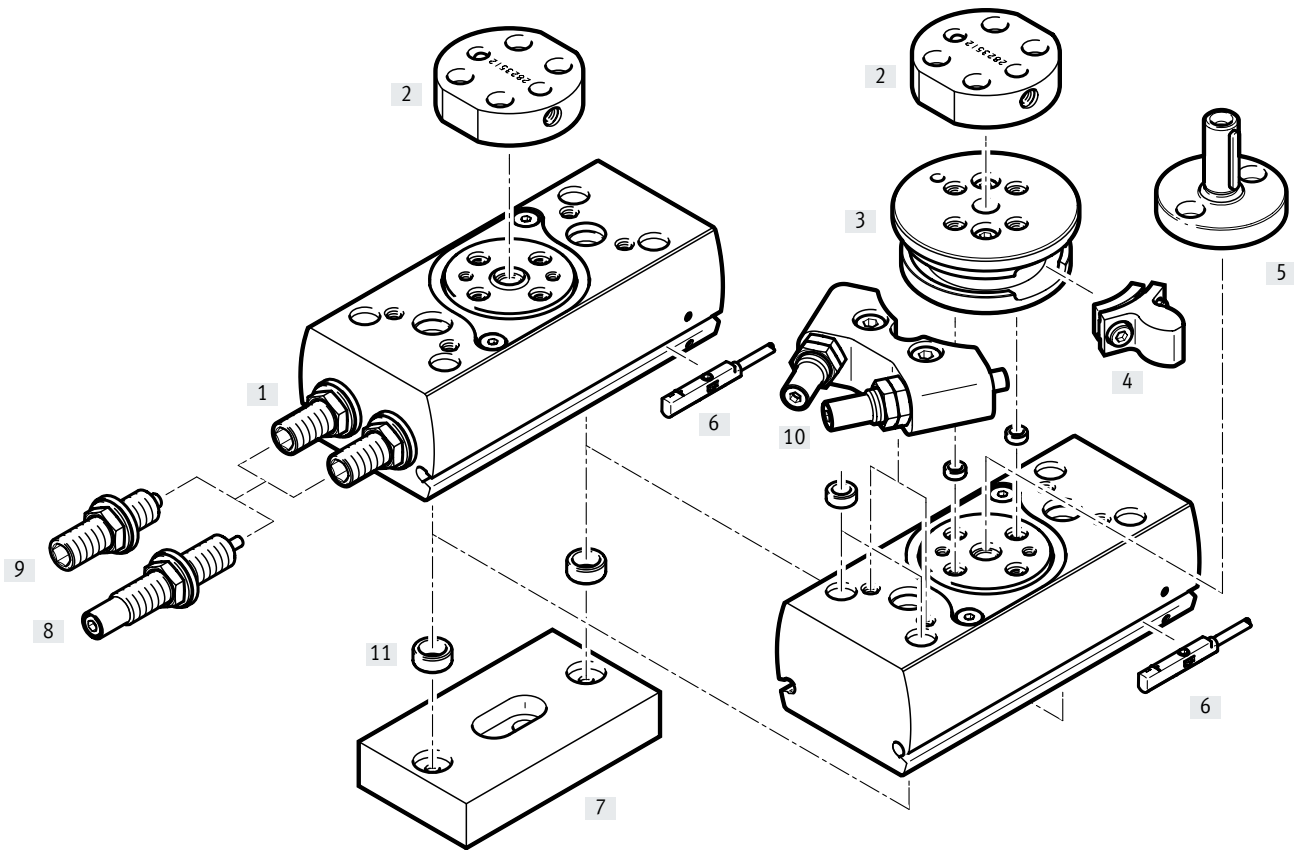

Peripherals overview

| Variants, mounting components and accessories | | Description | Size | | | → Page/ Internet |
|---|---------------------------------|---|------|----|----|---------------------|
| | | | 8 | 10 | 12 | |
| [1] | Semi-rotary drive DRRD | Double-acting | ■ | ■ | ■ | 6 |
| [2] | Adapter kit DHAA | <ul style="list-style-type: none"> Connecting plate between semi-rotary drive and gripper Included in the scope of delivery: 2 centring sleeves and screws | ■ | ■ | ■ | gripper |
| [3] | Flange module | <ul style="list-style-type: none"> Required for mounting the component [4] | – | – | ■ | 18 |
| [4] | Stop element | <ul style="list-style-type: none"> Serves as an end stop in combination with external shock absorbers (Y12) Two stop elements are included in the scope of delivery of external shock absorbers (Y12) | – | – | ■ | 18 |
| [5] | Drive shaft DARF-Q11 | <ul style="list-style-type: none"> The interface corresponds with that of semi-rotary drive DRQD The drive shaft should only be mounted directly onto the flange shaft Suitable for ATEX | – | – | ■ | 56 |
| [6] | Proximity switch SMT/SME-10 | For sensing the piston position | ■ | ■ | ■ | 60 |
| [7] | Adapter kit DHAA | Connecting plate between semi-rotary drive and drive | ■ | ■ | ■ | 65 |
| [8] | Shock absorber Y9 | Linear shock absorber, self-adjusting at both ends | – | – | ■ | 19 |
| [9] | Shock absorber P | Elastic cushioning elements with metal end position, at both ends | ■ | ■ | ■ | 19 |
| [10] | Shock absorber, external Y12 | <ul style="list-style-type: none"> Linear shock absorber, self-adjusting at both ends, external Included in the scope of delivery: [3], 2x [4], [10] | – | – | ■ | 19 |
| [11] | Centring sleeve ZBH | For centring attachments (two centring sleeves for mounting the semi-rotary drive included in the scope of delivery) | ■ | ■ | ■ | 59 |

Data sheet

Function

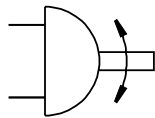

- - Diameter
8 ... 12 mm

- - Torque
0.2 ... 0.8 Nm

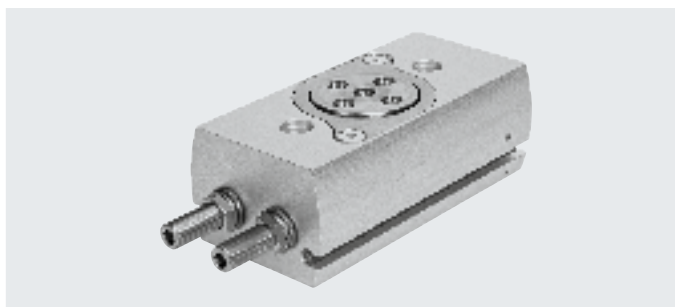

| General technical data | | 8 | 10 | 12 |
|-----------------------------|------|---------------------------------|------|---|
| Size | | 8 | 10 | 12 |
| Design | | Gear rack/pinion | | |
| Mode of operation | | Double-acting | | |
| Pneumatic connection | | M3 | M3 | M5 |
| Type of mounting | | With through-hole | | |
| | | Via female thread | | |
| Swivel angle | [°] | 180 (→ page 10) | | |
| Cushioning with fixed stop | | | | |
| DRRD-...-P | | Elastic cushioning at both ends | | |
| DRRD-...-Y9 | | - | | Linear shock absorber, self-adjusting at both ends |
| DRRD-...-Y12 | | - | | External linear shock absorber, self-adjusting at both ends |
| Repetition accuracy | [°] | ≤ 0.03 | | |
| Axial run-out ¹⁾ | [mm] | ≤ 0.02 | | |
| Max. axial load (static) | | | | |
| Pulling | [N] | 260 | 260 | 330 |
| Pushing | [N] | 700 | 1100 | 1400 |
| Mounting position | | Any | | |

1) Axial run-out in new condition

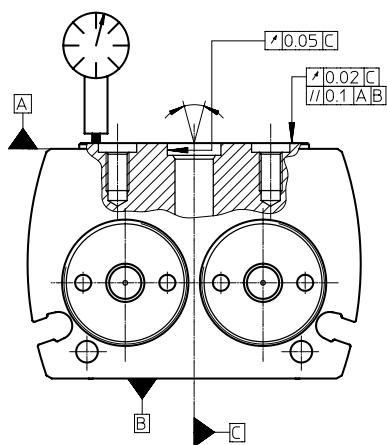

Data sheet

| Operating and environmental conditions | | |
|--|-------|--|
| Operating medium | | Compressed air to ISO 8573-1:2010 [7:4:4] |
| Note on operating/pilot medium | | Lubricated operation possible (in which case lubricated operation will always be required) |
| Operating pressure | | |
| DRRD-...-P | [bar] | 3 ... 8 |
| DRRD-...-Y9/-Y12 | [bar] | 2 ... 10 |
| Ambient temperature | [°C] | -10 ... +60 |
| Storage temperature | [°C] | -20 ... +60 |

| Weights [g] | | | |
|--------------|-----|-----|-----|
| Size | 8 | 10 | 12 |
| DRRD-...-P | 155 | 245 | 380 |
| DRRD-...-Y9 | - | - | 385 |
| DRRD-...-Y12 | - | - | 500 |

| Forces and torques | | | | |
|---|----------------------|-----|-----|-----|
| Size | 8 | 10 | 12 | |
| Theoretical torque at 6 bar | [Nm] | 0.2 | 0.4 | 0.8 |
| Max. permissible mass moment of inertia | | | | |
| DRRD-...-P | [kgcm ²] | 15 | 20 | 80 |
| DRRD-...-Y9 | [kgcm ²] | - | - | 300 |
| DRRD-...-Y12 | [kgcm ²] | - | - | 300 |

 **Note**

If, in the end positions, a torque which exceeds 50% of the theoretical torque acts against the direction of rotation, no exact end position is guaranteed.

This can be avoided by using external shock absorbers (Y12) or a semi-rotary drive with double the torque.

Materials

Sectional view

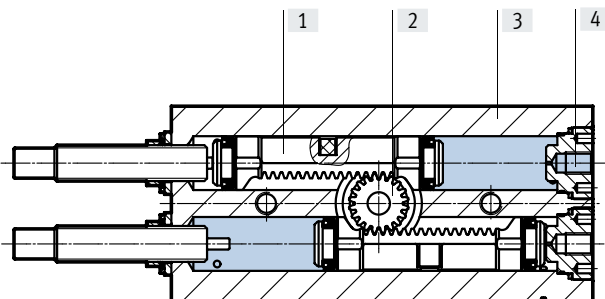

| Semi-rotary drive | |
|-------------------|--|
| [1] Piston | Copper base alloy |
| [2] Flange shaft | High-alloy stainless steel |
| [3] Housing | Smooth-anodised wrought aluminium alloy |
| [4] Port plug | High-alloy stainless steel |
| Seals | NBR |
| Piston seal | TPE-U(PU) |
| Note on materials | RoHS-compliant |
| | Contains paint-wetting impairment substances |

Data sheet

Swivel angle

Fundamentally, the following applies:

Swivel angle $\alpha \geq$ cushioning angle β

Swivel angle $\alpha = 180^\circ + \Delta\alpha_{\text{right}} + \Delta\alpha_{\text{left}}$

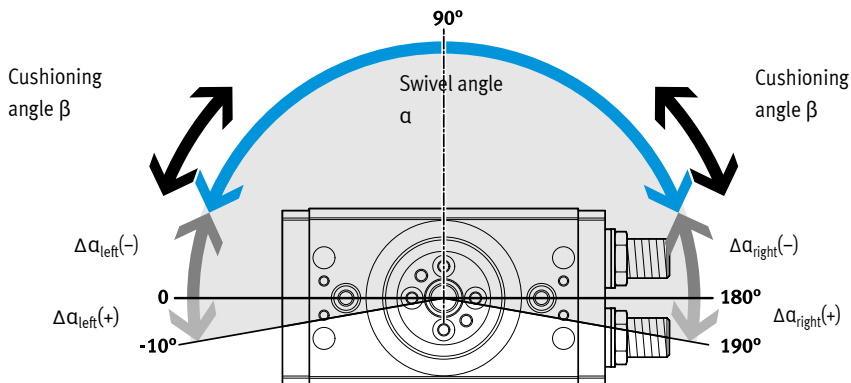

| Size | | 8 | 10 | 12 |
|---|-----|---------------------|----|------------|
| Swivel angle α | [°] | 180 | | |
| Min. swivel angle $\alpha^{1)}$ | | | | |
| DRRD-...-P | [°] | 38 | 37 | 32 |
| DRRD-...-Y9 | [°] | - | - | 48 |
| DRRD-...-Y12 | [°] | - | - | 20 |
| Max. swivel angle α | | | | |
| DRRD-... | [°] | 200 | | |
| DRRD-...-Y12 | [°] | - | - | 192 |
| Swivel angle adjustment α per side (infinitely adjustable) | | | | |
| DRRD-...-P | [°] | -100 ... +10 | | |
| DRRD-...-Y9 | [°] | ≥ -100 ... +10 | | |
| DRRD-...-Y12 | [°] | - | - | -92 ... +6 |
| Cushioning angle α | | | | |
| DRRD-...-P | [°] | 38 | 37 | 32 |
| DRRD-...-Y9 | [°] | - | - | 48 |
| DRRD-...-Y12 | [°] | - | - | 10 |

1) It is possible to set smaller swivel angles. However, this reduces the cushioning energy.

Swivel angle adjustment

Clockwise direction of rotation:

- Swivel angle decreases

Anticlockwise direction of rotation:

- Swivel angle increases

The swivel angle is adjusted via the cushioning elements using an Allen key. Any reduction in the swivel angle should preferably be evenly split between the two end positions.

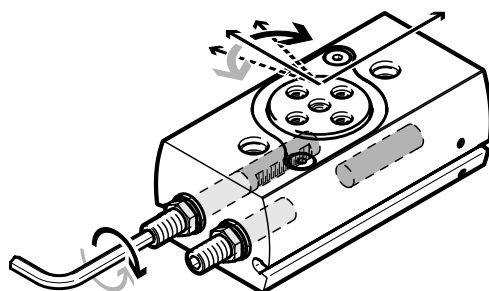

Data sheet

Max. permissible mass moment of inertia J at the flange shaft as a function of swivel time t
(at room temperature and an operating pressure of 6 bar)

Size 8 with cushioning P

Swivel angle $90^\circ/180^\circ$

Size 10 with cushioning P

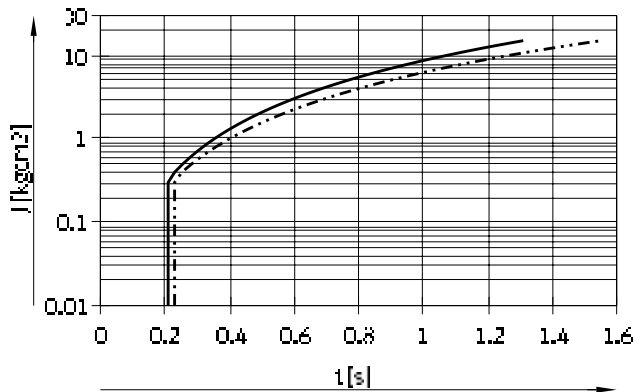

— DRRD-8-...-P (90°) Ranges
→ 0 ... 15 kgcm²
- - - - - DRRD-8-...-P (180°) Ranges
→ 0 ... 15 kgcm²

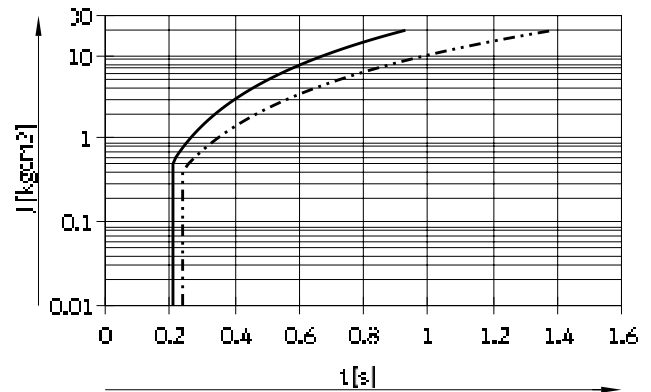

— DRRD-10-...-P (90°) Ranges
→ 0 ... 20 kgcm²
- - - - - DRRD-10-...-P (180°) Ranges
→ 0 ... 20 kgcm²

Size 12 with cushioning P/Y9

Swivel angle 90°

Swivel angle 180°

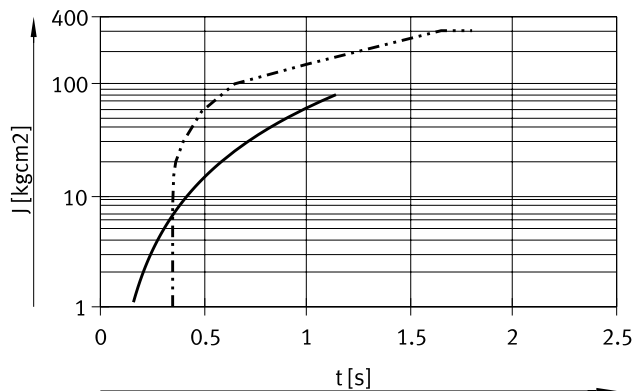

— DRRD-12-...-P (90°) Ranges
→ 0 ... 80 kgcm²
- - - - - DRRD-12-...-Y9 (90°) Ranges
→ 0 ... 300 kgcm²

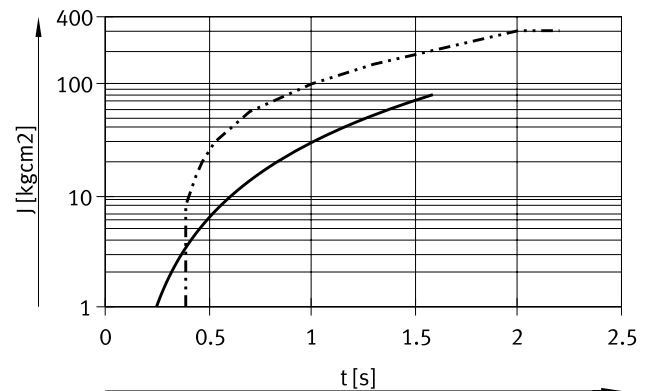

— DRRD-12-...-P (180°) Ranges
→ 0 ... 80 kgcm²
- - - - - DRRD-12-...-Y9 (180°) Ranges
→ 0 ... 300 kgcm²

Size 12 with cushioning Y12

Swivel angle $90^\circ/180^\circ$

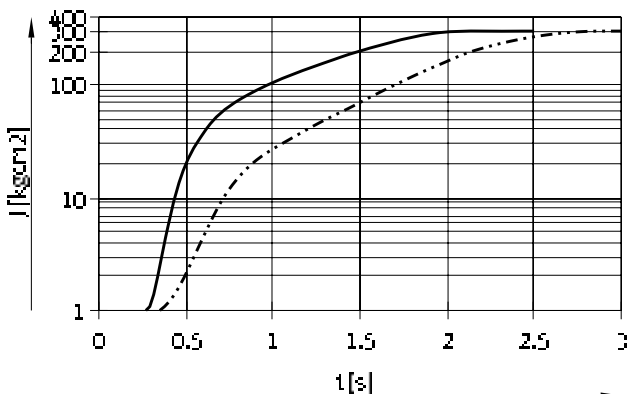

— DRRD-12-...-Y12 (90°) Ranges
→ 1 ... 300 kgcm²
- - - - - DRRD-12-...-Y12 (180°) Ranges
→ 1 ... 300 kgcm²

Data sheet

Max. load capacity at the flange shaft

The zero point for dimension z is always the flange level of the basic drive, independently of the attachments (flange module).

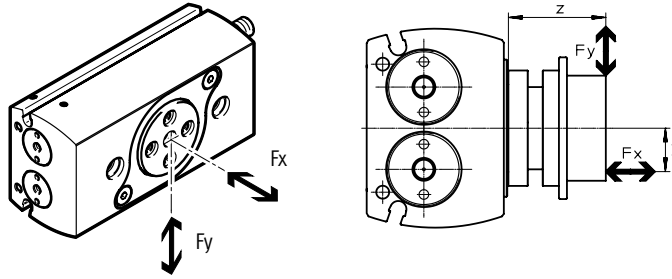

The following equation applies to combined loads (axial and radial):

$$\frac{F_y(z)}{F_{y\max.}(z)} + \frac{F_x(y)}{F_{x\max.}(y)} \leq 1$$

Dynamic values

Max. radial force F_y as a function of distance z

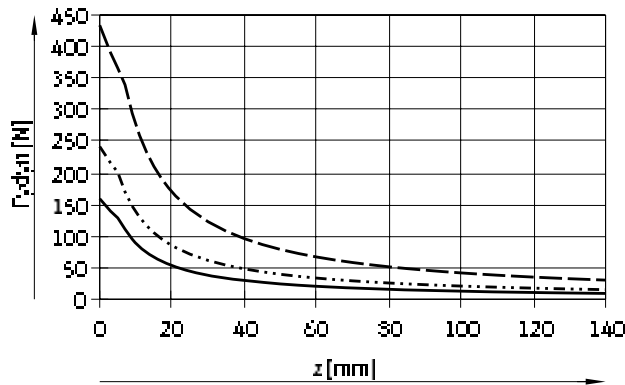

— DRRD-8
 - - - DRRD-10
 - · - · DRRD-12

Max. axial force F_x as a function of distance y

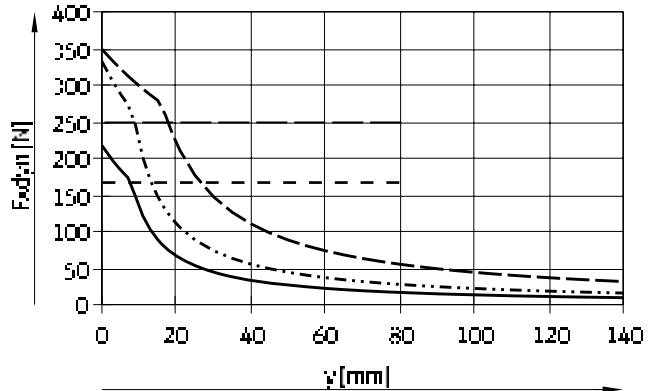

····· Tensile force limit DRRD-8/10
 - · - · Tensile force limit DRRD-12

Static values

Max. radial force F_y as a function of distance z

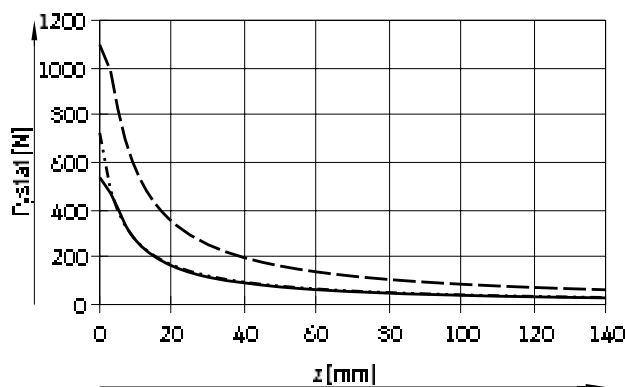

— DRRD-8
 - - - DRRD-10
 - · - · DRRD-12

Max. axial force F_x as a function of distance y

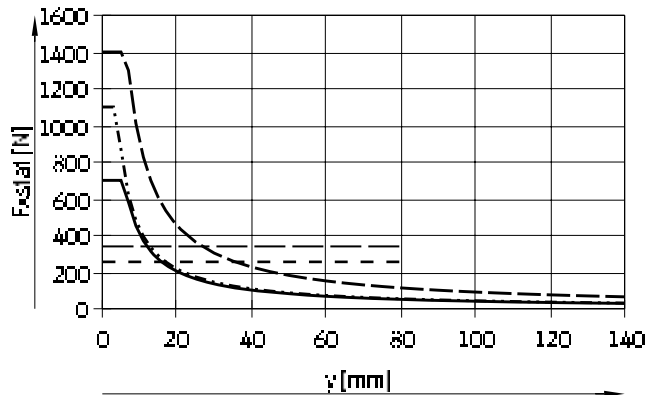

····· Tensile force limit DRRD-8/10
 - · - · Tensile force limit DRRD-12

Data sheet

Max. load capacity on the drive shaft (DARF-Q11)Max. radial forces F_y / axial forces F_x / bending moment M

- For the radial forces F_y , the limits of the flange shaft → page 14 and max. bending moment of the drive shaft apply → table below.
- The bending moment represents the load limit of the drive shaft and must not be exceeded.
- The zero point for dimension z is always the flange level of the basic drive, independently of the attachments (flange module).
- The axial force represents an additional load.

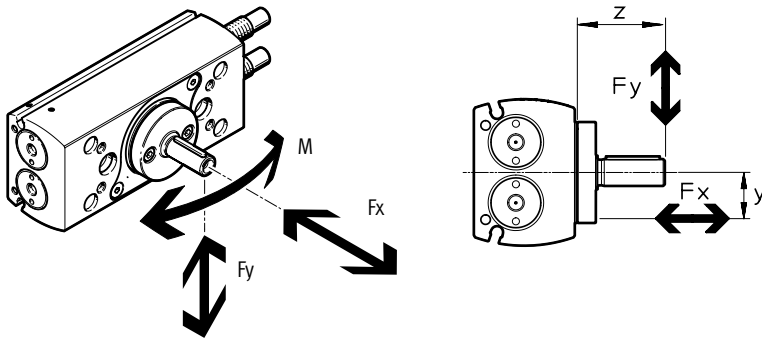

| | | |
|--------------------|------|------|
| Size | | 12 |
| Axial force F_x | [N] | 170 |
| Bending moment M | [Nm] | 5.44 |

Data sheet

Dimensions

Download CAD data → www.festo.com

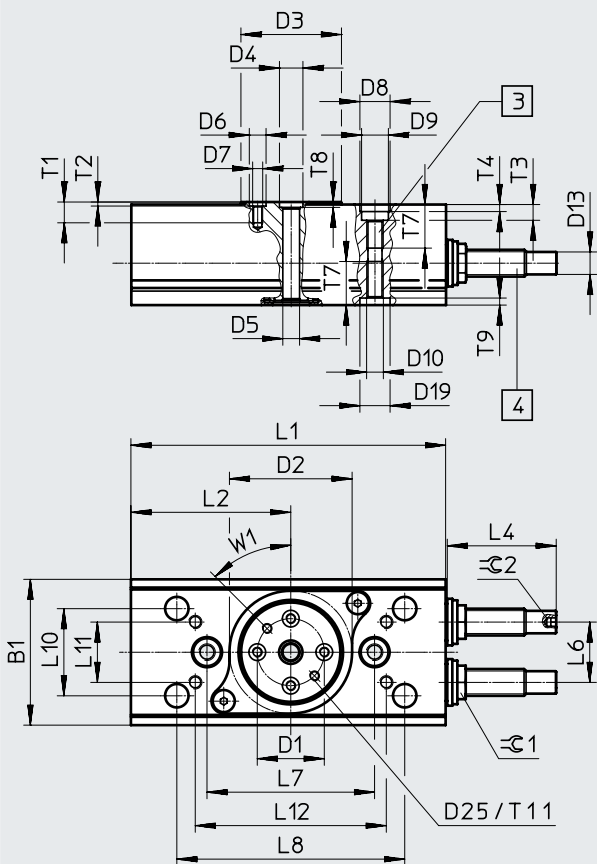

DRRD-8/10

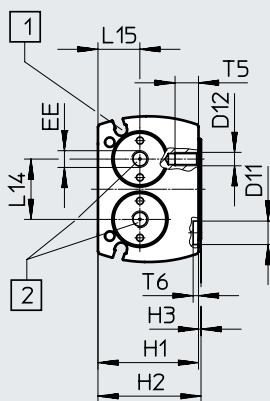

DRRD-...-P

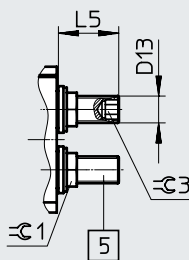
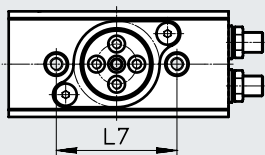

Note

Illustrated position of the flange shaft corresponds to the mid-position (swivel angle 90°).

Dimensions D25, T11 and W1 only for size 12

- [1] Sensor slots for proximity switch
- [2] Supply ports
- [3] Mounting thread
- [4] Shock absorber (DRRD-...-Y9)
- [5] Cushioning elements (DRRD-...-P)

Data sheet

| Size | B1 ±0.25 | D1 ∅ ±0.025 | D2 ∅ +0.1 | D3 ∅ | D4 ∅ H7 | D5 ∅ ±0.1 | D6 ∅ H7 | D7 | D8 ∅ H7 | D9 ∅ | D10 |
|------|-------------|-------------------|-----------------|---------|---------------|-----------------|---------------|----|---------------|---------|-----|
| 8 | 31.5 | 12 | 26 | 20.4 | 5 | 3 | 5 | M3 | 7 | 6 | M4 |
| 10 | 38 | 15 | 32 | 24 | 5 | 3 | 5 | M3 | 7 | 6 | M4 |
| 12 | 43.5 | 20 | 37 | 30 | 7 | 5 | 5 | M3 | 9 | 8 | M5 |

| Size | D11 ∅ H7 | D12 | D13 | D19 ∅ H7 | D25 | H1 +0.4 | H2 ±0.2 | H3 +0.2/-0.6 | L1 ±0.1 | L2 +0.1 | L6 |
|------|----------------|-----|--------|----------------|-----|------------|------------|-----------------|------------|------------|----------------------|
| 8 | - | - | M6x0.5 | 7 | - | 24.5 | 25.25 | 0.75 | 65.6 | 32.2 | 13 _{-0.1} |
| 10 | - | - | M6x0.5 | 7 | - | 27.5 | 28.25 | 0.75 | 74 | 38.3 | 15.2 _{-0.1} |
| 12 | 7 | M4 | M8x1 | 9 | M3 | 30 | 30.75 | 0.75 | 93.9 | 47.7 | 18 ^{+0.1} |

| Size | L7 ±0.02 | L8 ±0.2 | L10 ±0.02 | L11 ±0.15 | L12 ±0.2 | L14 | L15 -0.1 | T1 | T2 +0.1 | T3 | T4 +0.4/-0.1 |
|------|-------------|------------|--------------|--------------|-------------|------|-------------|-----|------------|-----|-----------------|
| 8 | 36 | - | - | - | - | 13 | 11.1 | 4.8 | 1.2 | 3.4 | 1.5 |
| 10 | 44 | - | - | - | - | 15.2 | 11.1 | 6.2 | 1.2 | 3.4 | 1.5 |
| 12 | 50 | 68 | 26 | 18 | 57 | 18 | 12.5 | 5.4 | 1.2 | 4.7 | 2.1 |

| Size | T5 | T6 +0.4/-0.1 | T7 | T8 +0.1 | T9 +0.1 | T11 | EE | W1 | ∠ 1 | ∠ 2 | ∠ 3 |
|------|----|-----------------|------|------------|------------|-----|----|-----|-----|-----|-----|
| 8 | - | - | 10.5 | 1.2 | 1.6 | - | M3 | - | 10 | - | 3 |
| 10 | - | - | 10 | 1.2 | 1.6 | - | M3 | - | 10 | - | 3 |
| 12 | 7 | 1.6 | 13 | 1.6 | 2.1 | 5.5 | M5 | 45° | 10 | 2.5 | 5 |

| Size | Dimension with 180° swivel angle | | Swivel angle adjustment range | | |
|------|----------------------------------|------|-------------------------------|-----------------|-------------|
| | L4 | L5 | L4 min./max. | L5 min./max. | 1 mm = ...° |
| 8 | - | 11.1 | - | -6.1/+0.8 | 16.4 |
| 10 | - | 12.6 | - | -7.6/+1.2 | 13.64 |
| 12 | 28 | 17 | -1.9/+1.9 | -11/+1.8 | 9.6 |

Data sheet

Dimensions – Variants

Download CAD data → www.festo.com

Y12 – With external shock absorber

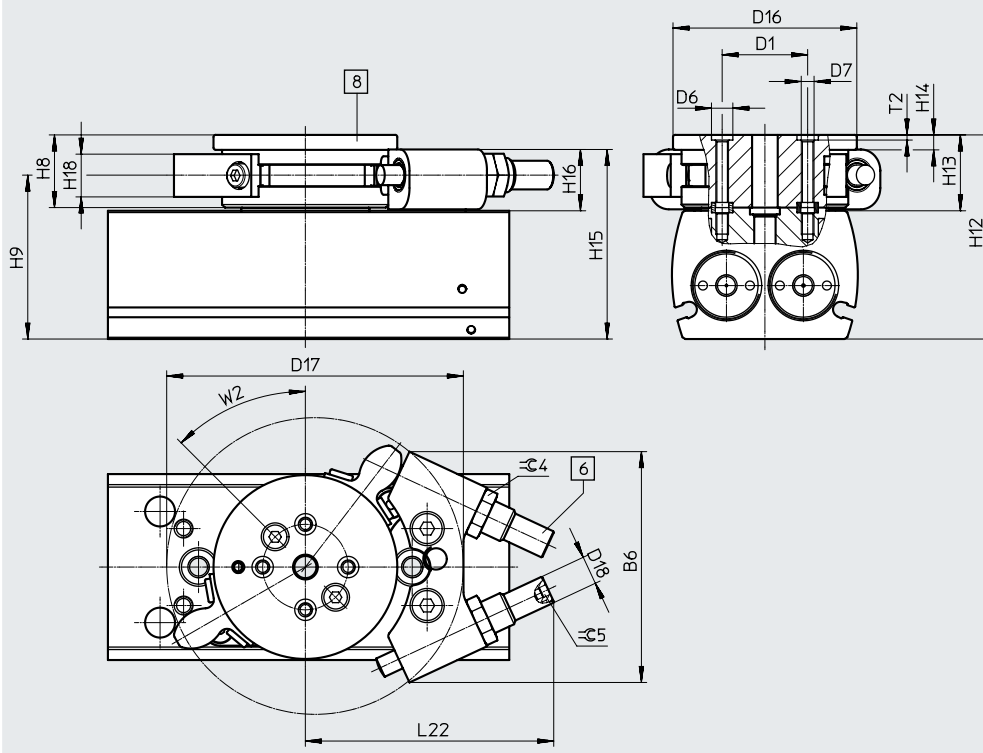

[6] Shock absorber
[8] Flange module

| | | | | | | | | | | |
|------|-------|--------------|---------|-----|----------|--------------|-------------|------------|-------|-------------|
| Size | B6 | D1 ∅ | D6 ∅ | D7 | D16 ∅ | D17 | D18 | H8 ±0.1 | H9 | H12 ±0.3 |
| 12 | 54 | 20 ±0.025 | 5 H7 | M3 | 43 | 69.4 | M8x1 | 17 | 38.25 | 47.75 |
| Size | H13 | H14 | H15 | H16 | H18 | L22 | T2 | W2 | ∠ 4 | ∠ 5 |
| 12 | 17.75 | 3.5 | 44 | 14 | 10 | 58.2 max. | 1.2 +0.1 | 45° | 10 | 2.5 |

Ordering data

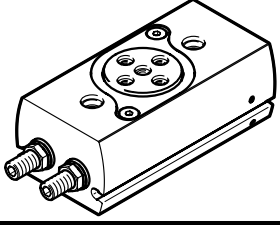
| Ordering data DRRD | Size | Swivel angle [°] | Part no. | Type |
|---|--|---------------------|----------|--------------------|
|  | P – Elastic cushioning rings/plates at both ends | | | |
| | 8 | 180 | 2223060 | DRRD-8-180-FH-PA |
| | 10 | | 2350968 | DRRD-10-180-FH-PA |
| | 12 | | 2282067 | DRRD-12-180-FH-PA |
| | Y9 – Linear shock absorber, self-adjusting at both ends | | | |
| | 12 | 180 | 2399248 | DRRD-12-180-FH-Y9A |
| | | | | |

| Ordering table – modular product system | | Conditions | Code | Enter code |
|---|--|------------|-------------|------------|
| Size | 12 | | | |
| Module no. | 574398 | | | |
| Function | Semi-rotary drive | | DRRD | DRRD |
| Size | 12 | | -12 | -12 |
| Nominal swivel angle | 180° | | -180 | -180 |
| Output shaft | Flange shaft, hollow | | -FH | -FH |
| Cushioning | Elastic cushioning rings/plates at both ends | | -P | |
| | Linear shock absorber, self-adjusting at both ends | | -Y9 | |
| | Linear shock absorber, self-adjusting at both ends, external | | -Y12 | |
| Position sensing | Via proximity switch | | A | A |
| Operating instructions | With operating instructions | | | |
| | Without operating instructions | | -DN | |

Peripherals overview

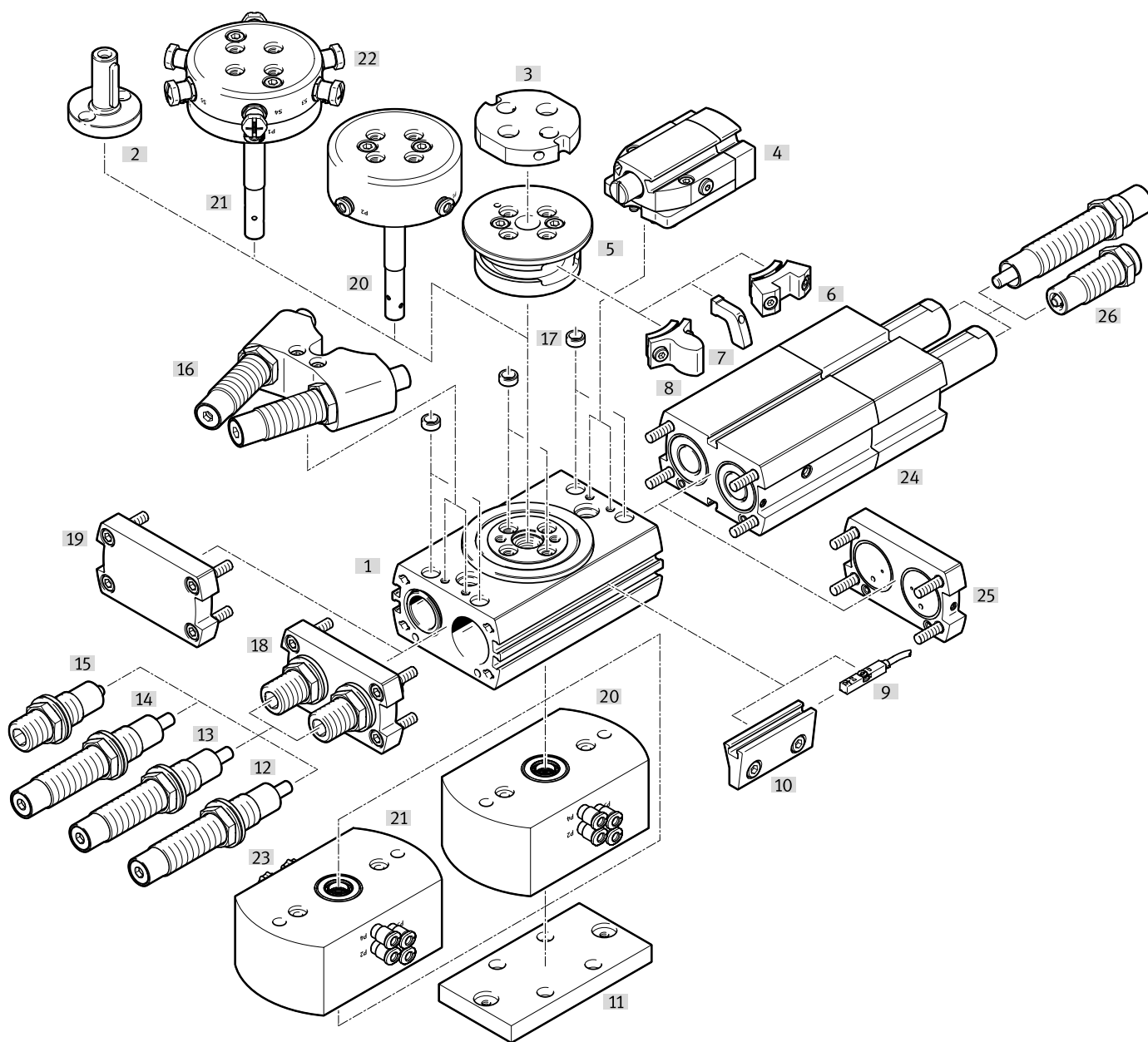

| Variants, mounting components and accessories | | Description | Size | | | | | | | → Page/ Internet | |
|---|--|---|------|----|----|----|----|----|----|---------------------|---------|
| | | | 16 | 20 | 25 | 32 | 35 | 40 | 50 | | 63 |
| [1] | Semi-rotary drive DRRD | Double-acting | ■ | ■ | ■ | ■ | ■ | ■ | ■ | ■ | 20 |
| [2] | Drive shaft ¹⁾ DARF-Q11 | <ul style="list-style-type: none"> The interface corresponds with that of semi-rotary drive DRQD The drive shaft should only be mounted directly onto the flange shaft Suitable for ATEX | ■ | ■ | ■ | ■ | ■ | ■ | - | - | 56 |
| [3] | Adapter kit DHAA | <ul style="list-style-type: none"> Connecting plate between semi-rotary drive and gripper Included in the scope of delivery: 2 centring sleeves and screws | ■ | ■ | ■ | ■ | ■ | ■ | ■ | - | gripper |
| [4] | End-position locking E1 ¹⁾ (clamping unit DADL-...-EL as an accessory) | <ul style="list-style-type: none"> Mechanical lock in the end positions to prevent unwanted movement when unpressurised Included in the scope of delivery: [4], [5], 2x [6] | ■ | ■ | ■ | ■ | ■ | ■ | ■ | ■ | 57 |

Peripherals overview

| Variants, mounting components and accessories | | Size | | | | | | | | → Page/ Internet |
|---|--|--|----|----|----|----|----|----|----|---------------------|
| | Description | 16 | 20 | 25 | 32 | 35 | 40 | 50 | 63 | |
| [5] | Flange module | Required to mount components [6], [7] and [8] | | | | | | | | 57 |
| [6] | Clamping component (Type: DADL-EC) | Secures the semi-rotary drive DRRD when the cylinder [4] is advanced | | | | | | | | 59 |
| [7] | Switch lug DASI-Q11-...SL | For sensing the piston position using e.g. inductive proximity switches SIES-8M → page 61, in combination with sensor bracket [10] | | | | | | | | 59 |
| [8] | Stop element | Serves as an end stop in combination with external shock absorbers (Y12) | | | | | | | | 55 |
| [9] | Proximity switch SMT/SME-8 | For sensing the piston position | | | | | | | | 60 |
| | Position transmitter SMAT-8M | Analogue position feedback from 0 ... 10 V possible | | | | | | | | 62 |
| [10] | Sensor mounting R (sensing kit DASI-...-KT as an accessory) | <ul style="list-style-type: none"> For sensing the piston position using e.g. inductive proximity switches SIES-8M → page 61 Included in the scope of delivery: [5], 2x [7], 2x [10] | | | | | | | | 58 |
| [11] | Adapter kit DHAA | Connecting plate between semi-rotary drive and drive | | | | | | | | adapter |
| [12] | Shock absorber Y9 | Linear shock absorber, self-adjusting at both ends | | | | | | | | 65 |
| [13] | Shock absorber, hard Y10 | Linear shock absorber, self-adjusting at both ends, hard | | | | | | | | 55 |
| [14] | Shock absorber, soft Y14 | Linear shock absorber, self-adjusting at both ends, soft | | | | | | | | 55 |
| [15] | Shock absorber P | Elastic cushioning elements with metal end position, at both ends | | | | | | | | 55 |
| [16] | Shock absorber, external Y12 | <ul style="list-style-type: none"> Linear shock absorber, self-adjusting at both ends, external Included in the scope of delivery: [5], 2x [8], [16] | | | | | | | | 55 |
| [17] | Centring sleeve ZBH | For centring attachment (2 pieces included in the scope of delivery of the drive) | | | | | | | | 59 |
| [18] | End cap | In conjunction with elastic cushioning element P or shock absorber Y9, Y10, Y14 | | | | | | | | - |
| [19] | End cap | In combination with external shock absorber Y12 | | | | | | | | - |
| [20] | Energy through-feed pneumatic | Enables the quick and easy pneumatic supply of parts connected to the flange (e.g. gripper) | | | | | | | | 37 |
| [21] | Energy through-feed pneumatic/electrical | Enables the quick and easy pneumatic/electrical supply of parts connected to the flange (e.g. gripper) | | | | | | | | 37 |
| [22] | Connecting cable NEBU | From the energy through-feed to the proximity switch | | | | | | | | 63 |
| [23] | Connecting cable NEBU | From the energy through-feed to the controller | | | | | | | | 63 |
| [24] | Intermediate position | Possible at 90° | | | | | | | | 40 |
| [25] | Connection cap | For the supply ports | | | | | | | | - |
| [26] | Shock absorber | The cushioning for the intermediate position corresponds to the cushioning for the basic drive. Except in the case of Y12 when shock absorbers Y9 are used | | | | | | | | 59 |
| - | One-way flow control valves GRLA | To set the swivel speed | | | | | | | | 64 |

1) The combination of drive shaft [2] and end-position locking E1 [4] is not possible.

Data sheet

Function

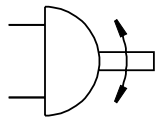

⊘ Diameter
16 ... 63 mm

≡ Torque
1.6 ... 112 Nm

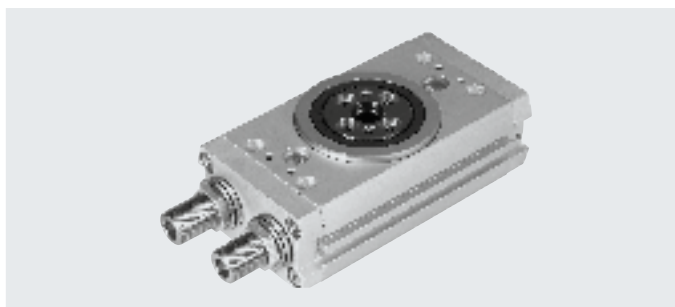

| General technical data | | 16 | 20 | 25 | 32 | 35 | 40 | 50 | 63 |
|-----------------------------|------|---|--|------|------|------|--|-------|-------|
| Size | | 16 | 20 | 25 | 32 | 35 | 40 | 50 | 63 |
| Design | | Gear rack/pinion | | | | | | | |
| Mode of operation | | Double-acting | | | | | | | |
| Pneumatic connection | | | | | | | | | |
| DRRD-... | | M5 | | | G1/8 | | G1/4 | | G3/8 |
| DRRD-...-PS1 | | M5 | | | | | | | |
| Type of mounting | | With through-hole | | | | | | | |
| | | Via female thread | | | | | | | |
| Swivel angle | | | | | | | | | |
| DRRD-... | [°] | 180 (→ page 25) | | | | | | | |
| DRRD-...-PS1 | [°] | 90 ±10° | | | | | | | |
| Cushioning with fixed stop | | | | | | | | | |
| DRRD-...-P | | Elastic cushioning rings/plates at both ends | | | | | | - | |
| DRRD-...-Y9 | | Linear shock absorber, self-adjusting at both ends | | | | | | | |
| DRRD-...-Y10 ¹⁾ | | - | Linear shock absorber, self-adjusting at both ends, hard | | | - | Linear shock absorber, self-adjusting at both ends, hard | | |
| DRRD-...-Y12 | | External linear shock absorber, self-adjusting at both ends | | | | | | | |
| DRRD-...-Y14 ¹⁾ | | Linear shock absorber, self-adjusting at both ends, soft | | | | | | - | |
| Repetition accuracy | | | | | | | | | |
| DRRD-... | [°] | < 0.05 | | | | | | ≤0.03 | |
| DRRD-...-PS1 | | | | | | | | | |
| Approached from one end | [°] | 0.1 | | | | | | - | |
| Approached from both ends | [°] | 0.7 | | | | | | - | |
| Axial run-out ²⁾ | [mm] | < 0.05 | | | | | | | |
| Max. axial load (static) | [N] | 1500 | 2400 | 2400 | 3750 | 6100 | 6100 | 9000 | 11000 |
| Mounting position | | Any | | | | | | | |

1) Not in combination with intermediate position DRRD-...-PS1

2) Axial run-out in new condition

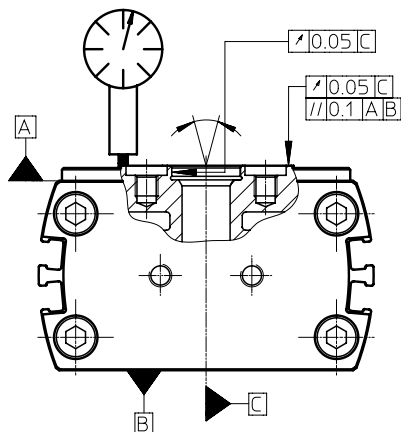

Data sheet

| Operating and environmental conditions | |
|--|--|
| Operating medium | Compressed air to ISO 8573-1:2010 [7:4:4] |
| Note on operating/pilot medium | Lubricated operation possible (in which case lubricated operation will always be required) |
| Operating pressure | |
| DRRD-... | |
| DRRD-...-P | [bar] 3 ... 8 |
| DRRD-...-Y9/-Y10/-Y12/-Y14 | [bar] 2 ... 10 |
| DRRD-...-PS1 | |
| DRRD-...-P | [bar] 4 ... 8 |
| DRRD-...-Y9/-Y12 | [bar] 2 ... 10 |
| Ambient temperature | [°C] -10 ... +60 |
| Storage temperature | [°C] -20 ... +60 |
| Degree of protection based on EN 60529 | |
| DRRD-...-SG | IP65 |

| ATEX ¹⁾ | |
|--|---|
| ATEX category for gas | II 2G |
| Type of ignition protection for gas | Ex h IIC T4 Gb |
| ATEX category for dust | II 2D |
| Type of ignition protection for dust | Ex h IIIC T120°C Db |
| Explosion-proof ambient temperature | -10°C ≤ Ta ≤ +60°C |
| CE marking (see declaration of conformity) | To EU Explosion Protection Directive (ATEX) |

1) Note the ATEX certification of the accessories.

| Weights [g] | 16 | 20 | 25 | 32 | 35 | 40 | 50 | 63 |
|---|-----|------|------|------|------|------|-------|-------|
| Size | | | | | | | | |
| Basic drive with cushioning | | | | | | | | |
| DRRD-...-P | 640 | 839 | 1349 | 2815 | 4510 | 6070 | - | - |
| DRRD-...-Y9/-Y10/-Y14 | 650 | 883 | 1358 | 2976 | 4784 | 6424 | 11300 | 19100 |
| DRRD-...-Y12 | 757 | 1132 | 1705 | 3760 | 5425 | 7160 | 12450 | 22400 |
| Energy through-feed (additional) | | | | | | | | |
| DRRD-...-P | 320 | 350 | 710 | 920 | 1090 | 1470 | 1950 | 2250 |
| DRRD-...-P...E... | 460 | 480 | 720 | 900 | 880 | 1770 | 2330 | 2610 |
| Intermediate position (additional) | | | | | | | | |
| DRRD-...-P | 502 | 701 | 1078 | 2304 | - | - | - | - |
| DRRD-...-Y9 | 511 | 720 | 1130 | 2450 | 3940 | 4380 | 8270 | - |
| End-position locking (additional) | | | | | | | | |
| DRRD-...-E1 | 166 | 382 | 370 | 600 | 900 | 900 | 1610 | 2380 |
| Sensor mounting, external (additional) | | | | | | | | |
| DRRD-...-R | 110 | 192 | 192 | 366 | 485 | 485 | 810 | 1390 |

Data sheet

| Forces and torques | | | | | | | | | |
|--|----------------------|-----|------|------|-------|-------|-------|--------|--------|
| Size | | 16 | 20 | 25 | 32 | 35 | 40 | 50 | 63 |
| Theoretical torque at 6 bar | [Nm] | 1.6 | 2.4 | 5.1 | 10.1 | 15.8 | 24.1 | 53 | 112 |
| Max. permissible mass moment of inertia | | | | | | | | | |
| Rotation from end position to end position | | | | | | | | | |
| DRRD-...-P | [kgcm ²] | 175 | 400 | 900 | 1500 | 2500 | 6700 | – | – |
| DRRD-...-Y9 | [kgcm ²] | 700 | 1250 | 1500 | 26000 | 15000 | 23000 | 40000 | 40000 |
| DRRD-...-Y10 | [kgcm ²] | – | – | 5500 | – | 45000 | 67000 | 200000 | 420000 |
| DRRD-...-Y12 | [kgcm ²] | 900 | 1500 | 5500 | 26000 | 45000 | 67000 | 200000 | 420000 |
| DRRD-...-Y14 | [kgcm ²] | 100 | 150 | 100 | 2000 | 2000 | 23000 | – | – |
| Rotation with intermediate position | | | | | | | | | |
| DRRD-...-P | [kgcm ²] | 150 | 300 | 400 | 500 | – | – | – | – |
| DRRD-...-Y9 | [kgcm ²] | 500 | 900 | 1500 | 8000 | 15000 | 23000 | 40000 | – |
| DRRD-...-Y12 | [kgcm ²] | 500 | 900 | 1500 | 8000 | 15000 | 23000 | 40000 | – |

Note

If, in the end positions, a torque which exceeds 50% of the theoretical torque acts against the direction of rotation, no exact end position is guaranteed.

This can be avoided by using external shock absorbers (Y12) or a semi-rotary drive with double the torque.

Note

The cushioning for the intermediate position corresponds to the cushioning for the basic drive. Except in the case of cushioning Y12, when shock absorbers Y9 are used.

In combination with cushioning P, the intermediate position is only available for sizes 16 ... 32.

Materials

Sectional view

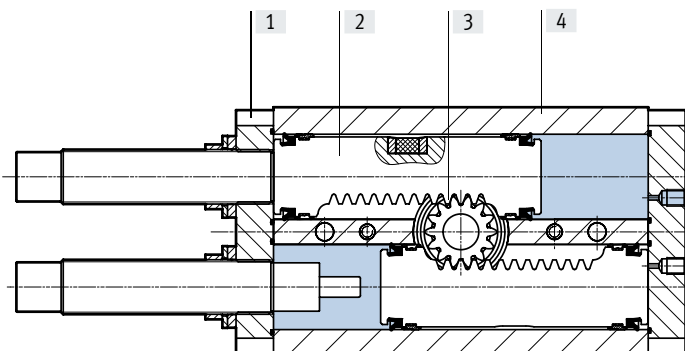

Semi-rotary drive

| | |
|-------------------|--|
| [1] Cover | Anodised wrought aluminium alloy |
| [2] Piston | Stainless steel |
| [3] Flange shaft | Tempered steel |
| [4] Housing | Smooth-anodised wrought aluminium alloy |
| Seals | NBR |
| Piston seal | TPE-U(PU) |
| Note on materials | RoHS-compliant |
| | Contains paint-wetting impairment substances |

Data sheet

Swivel angle

Fundamentally, the following applies:

Swivel angle $\alpha \geq$ cushioning angle β

Swivel angle $\alpha = 180^\circ + \Delta\alpha_{\text{right}} + \Delta\alpha_{\text{left}}$

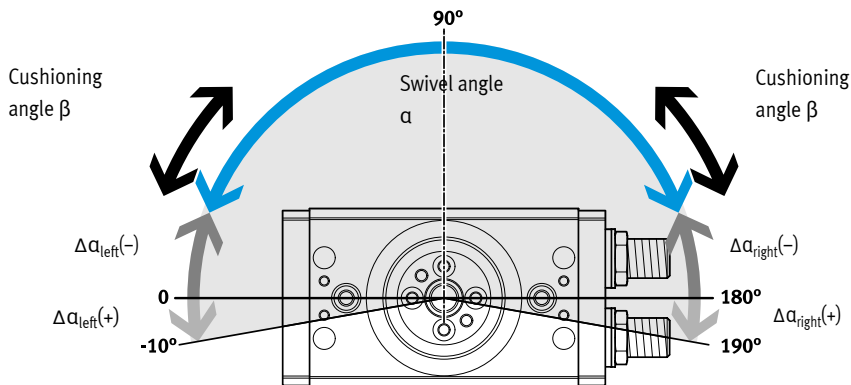

Note
Illustrated position of the flange shaft corresponds to the mid-position (swivel angle 90°)

| Size | | 16 | 20 | 25 | 32 | 35 | 40 | 50 | 63 | |
|---|-----|-----------------------|------------|------------|------------|--------------|------------|------------|-----|--|
| Swivel angle α | [°] | 180 | | | | | | | | |
| Min. swivel angle α^1 | | | | | | | | | | |
| DRRD-...P | [°] | 36 | 45 | 33 | 33 | 36 | 23 | - | - | |
| DRRD-...Y9/-Y10/-Y14 | [°] | 43 | 72 | 79 | 82 | 85 | 56 | 61 | 48 | |
| DRRD-...Y12 | [°] | 20 | 24 | 38 | 34 | 34 | 34 | 30 | 34 | |
| DRRD-...E1 | [°] | 60 | 60 | 60 | 55 | 57 | 57 | 62 | 55 | |
| Max. swivel angle α^2 | | | | | | | | | | |
| DRRD-... | [°] | 200 | | | | | | | | |
| DRRD-...Y12 | [°] | 192 | 194 | 190 | 190 | 193 | 193 | 186 | 190 | |
| Swivel angle adjustment α per side (infinitely adjustable) | | | | | | | | | | |
| DRRD-...P | [°] | -100 ... +10 | | | | | | - | - | |
| DRRD-...Y9/-Y10/-Y14 | [°] | $\geq -100 \dots +10$ | | | | | | | | |
| DRRD-...Y12 | [°] | -94 ... +6 | -85 ... +7 | -88 ... +5 | -93 ... +5 | -86 ... +6.5 | -86 ... +3 | -91 ... +5 | | |
| Cushioning angle β | | | | | | | | | | |
| DRRD-...P | [°] | 36 | 45 | 33 | 33 | 36 | 23 | - | - | |
| DRRD-...Y9/-Y10/-Y14 | [°] | 43 | 72 | 79 | 82 | 85 | 56 | 61 | 48 | |
| DRRD-...Y12 | [°] | 10 | 12 | 19 | 17 | 17 | 17 | 15 | 17 | |

- 1) It is possible to set smaller swivel angles. However, this reduces the cushioning energy
 2) The max. swivel angle is reduced by approx. 10° in combination with the external sensor mounting

Swivel angle adjustment

Clockwise direction of rotation:

- Swivel angle decreases

Anticlockwise direction of rotation:

- Swivel angle increases

The swivel angle is adjusted via the cushioning elements using an Allen key. Any reduction in the swivel angle should preferably be evenly split between the two end positions.

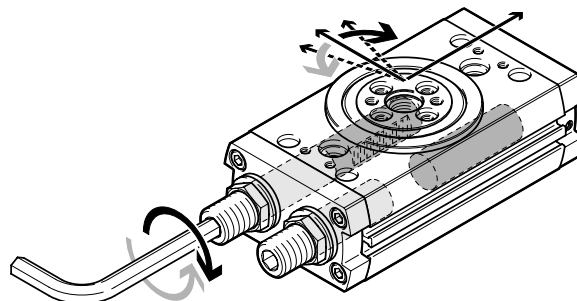

Swivel angle adjustment of the intermediate position → page 40

Data sheet

Max. permissible mass moment of inertia J at the flange shaft as a function of swivel time t (at room temperature and an operating pressure of 6 bar)

Size 16 with cushioning P/Y9/Y14

Swivel angle 90°

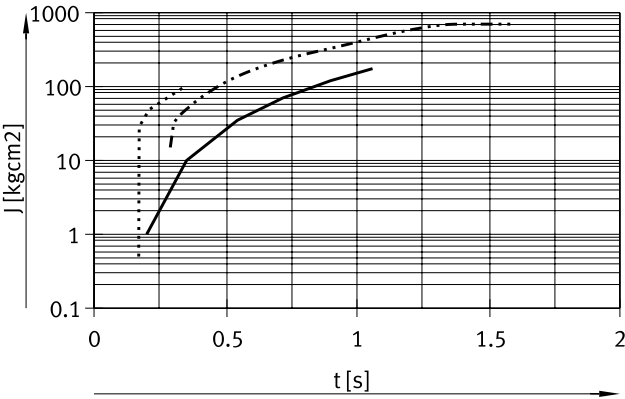

- | | | | |
|-------|-----------------------|--------|---------------------------------|
| — | DRRD-16-...-P (90°) | Ranges | → 1 ... 175 kgcm ² |
| - - - | DRRD-16-...-Y9 (90°) | | → 15 ... 700 kgcm ² |
| | DRRD-16-...-Y14 (90°) | | → 0.5 ... 100 kgcm ² |

Swivel angle 180°

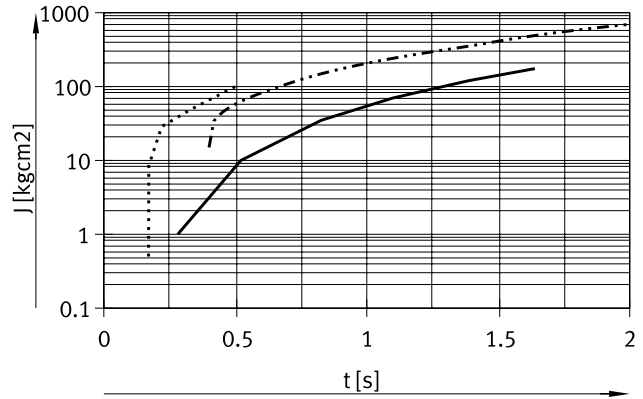

- | | | | |
|-------|------------------------|--------|---------------------------------|
| — | DRRD-16-...-P (180°) | Ranges | → 1 ... 175 kgcm ² |
| - - - | DRRD-16-...-Y9 (180°) | | → 15 ... 700 kgcm ² |
| | DRRD-16-...-Y14 (180°) | | → 0.5 ... 100 kgcm ² |

Size 20 with cushioning P/Y9/Y14

Swivel angle 90°

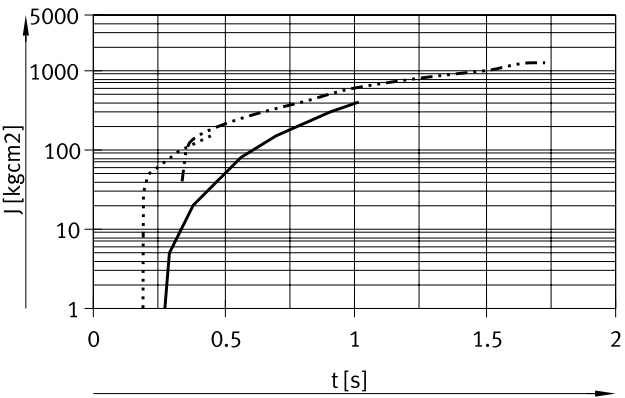

- | | | | |
|-------|-----------------------|--------|---------------------------------|
| — | DRRD-20-...-P (90°) | Ranges | → 1 ... 400 kgcm ² |
| - - - | DRRD-20-...-Y9 (90°) | | → 40 ... 1250 kgcm ² |
| | DRRD-20-...-Y14 (90°) | | → 1 ... 150 kgcm ² |

Swivel angle 180°

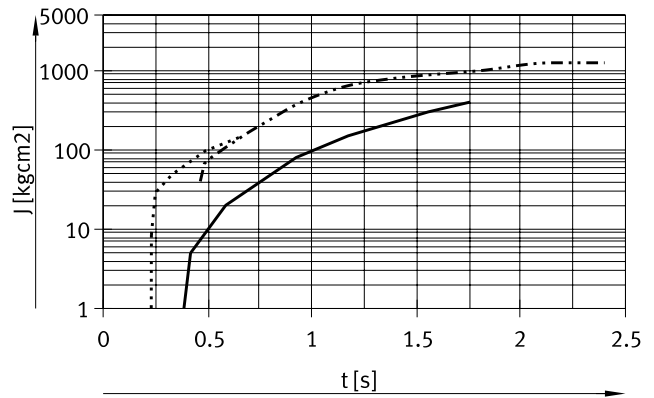

- | | | | |
|-------|------------------------|--------|---------------------------------|
| — | DRRD-20-...-P (180°) | Ranges | → 1 ... 400 kgcm ² |
| - - - | DRRD-20-...-Y9 (180°) | | → 40 ... 1250 kgcm ² |
| | DRRD-20-...-Y14 (180°) | | → 1 ... 150 kgcm ² |

Data sheet

Max. permissible mass moment of inertia J at the flange shaft as a function of swivel time t (at room temperature and an operating pressure of 6 bar)

Size 25 with cushioning P/Y9/Y10/Y14

Swivel angle 90°

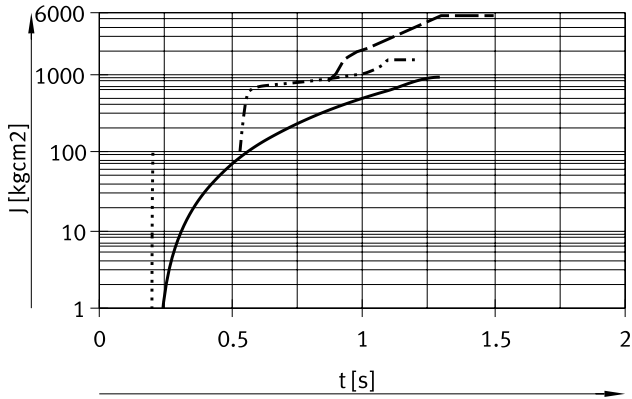

| | | | |
|-------------|-----------------------|--------|----------------------------------|
| — | DRRD-25-...-P (90°) | Ranges | → 1 ... 900 kgcm ² |
| - · - · - · | DRRD-25-...-Y9 (90°) | | → 100 ... 1500 kgcm ² |
| - - - - - | DRRD-25-...-Y10 (90°) | | → 800 ... 5500 kgcm ² |
| · · · · · | DRRD-25-...-Y14 (90°) | | → 1 ... 100 kgcm ² |

Swivel angle 180°

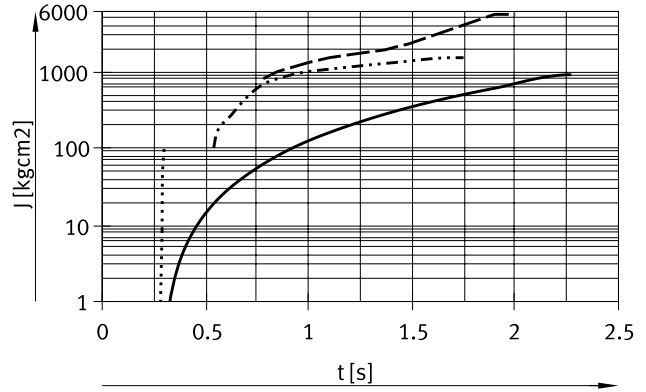

| | | | |
|-------------|------------------------|--------|----------------------------------|
| — | DRRD-25-...-P (180°) | Ranges | → 1 ... 900 kgcm ² |
| - · - · - · | DRRD-25-...-Y9 (180°) | | → 100 ... 1500 kgcm ² |
| - - - - - | DRRD-25-...-Y10 (180°) | | → 800 ... 5500 kgcm ² |
| · · · · · | DRRD-25-...-Y14 (180°) | | → 1 ... 100 kgcm ² |

Size 32 with cushioning P/Y9/Y14

Swivel angle 90°

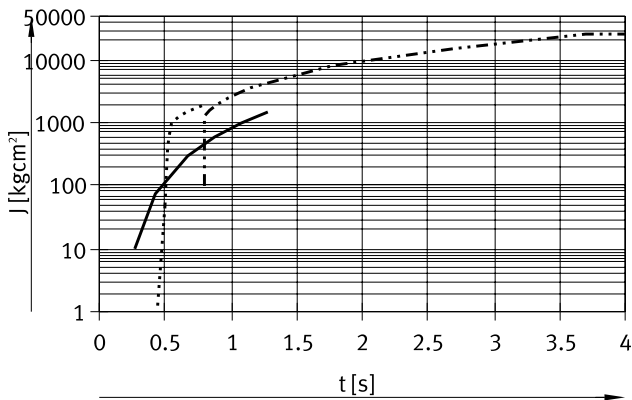

| | | | |
|-------------|-----------------------|--------|-----------------------------------|
| — | DRRD-32-...-P (90°) | Ranges | → 10 ... 1500 kgcm ² |
| - · - · - · | DRRD-32-...-Y9 (90°) | | → 100 ... 26000 kgcm ² |
| · · · · · | DRRD-32-...-Y14 (90°) | | → 1 ... 2000 kgcm ² |

Swivel angle 180°

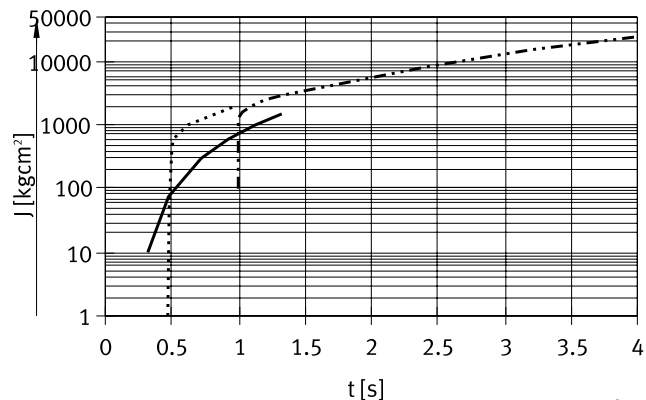

| | | | |
|-------------|------------------------|--------|-----------------------------------|
| — | DRRD-32-...-P (180°) | Ranges | → 10 ... 1500 kgcm ² |
| - · - · - · | DRRD-32-...-Y9 (180°) | | → 100 ... 26000 kgcm ² |
| · · · · · | DRRD-32-...-Y14 (180°) | | → 1 ... 2000 kgcm ² |

Data sheet

Max. permissible mass moment of inertia J at the flange shaft as a function of swivel time t (at room temperature and an operating pressure of 6 bar)

Size 35 with cushioning P/Y9/Y10/Y14

Swivel angle 90°

Swivel angle 180°

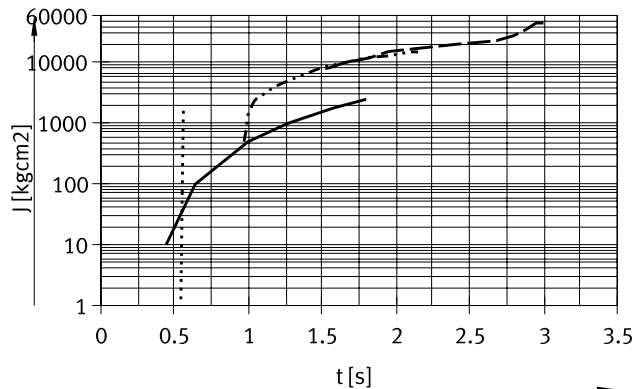
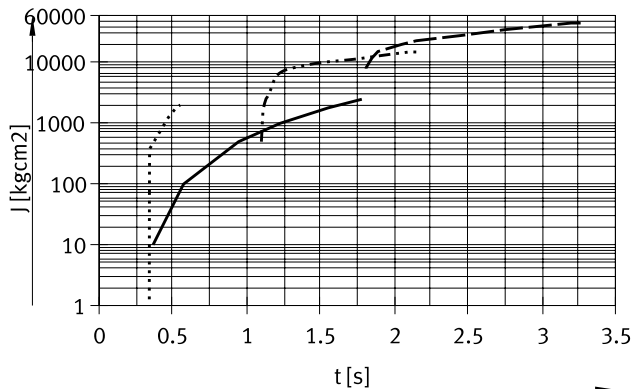

- | | | | |
|-----------|-----------------------|--------|------------------------------------|
| — | DRRD-35-...-P (90°) | Ranges | → 10 ... 2500 kgcm ² |
| ····· | DRRD-35-...-Y9 (90°) | | → 500 ... 15000 kgcm ² |
| - - - - | DRRD-35-...-Y10 (90°) | | → 8000 ... 45000 kgcm ² |
| - · - · - | DRRD-35-...-Y14 (90°) | | → 1 ... 2000 kgcm ² |

- | | | | |
|-----------|------------------------|--------|------------------------------------|
| — | DRRD-35-...-P (180°) | Ranges | → 10 ... 2500 kgcm ² |
| ····· | DRRD-35-...-Y9 (180°) | | → 500 ... 15000 kgcm ² |
| - - - - | DRRD-35-...-Y10 (180°) | | → 8000 ... 45000 kgcm ² |
| - · - · - | DRRD-35-...-Y14 (180°) | | → 1 ... 2000 kgcm ² |

Size 40 with cushioning P/Y9/Y10/Y14

Swivel angle 90°

Swivel angle 180°

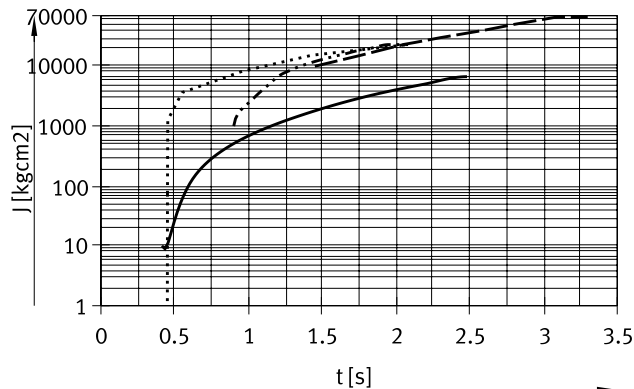
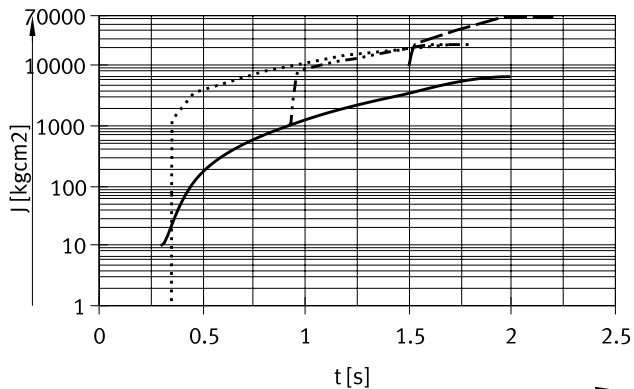

- | | | | |
|-----------|-----------------------|--------|-------------------------------------|
| — | DRRD-40-...-P (90°) | Ranges | → 10 ... 6700 kgcm ² |
| ····· | DRRD-40-...-Y9 (90°) | | → 1000 ... 23000 kgcm ² |
| - - - - | DRRD-40-...-Y10 (90°) | | → 10000 ... 67000 kgcm ² |
| - · - · - | DRRD-40-...-Y14 (90°) | | → 1 ... 23000 kgcm ² |

- | | | | |
|-----------|------------------------|--------|-------------------------------------|
| — | DRRD-40-...-P (180°) | Ranges | → 10 ... 6700 kgcm ² |
| ····· | DRRD-40-...-Y9 (180°) | | → 1000 ... 23000 kgcm ² |
| - - - - | DRRD-40-...-Y10 (180°) | | → 10000 ... 67000 kgcm ² |
| - · - · - | DRRD-40-...-Y14 (180°) | | → 1 ... 23000 kgcm ² |

Data sheet

Max. permissible mass moment of inertia J at the flange shaft as a function of swivel time t (at room temperature and an operating pressure of 6 bar)

Size 50 with cushioning Y9/Y10

Swivel angle 90°

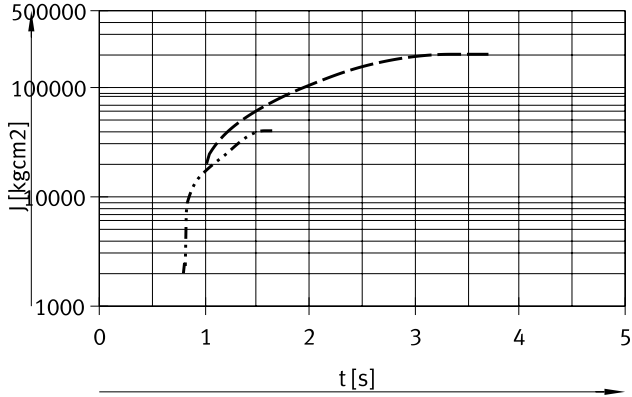

- | | | | |
|-------|-----------------------|--------|--------------------------------------|
| | DRRD-50-...-Y9 (90°) | Ranges | → 2000 ... 40000 kgcm ² |
| ---- | DRRD-50-...-Y10 (90°) | | → 20000 ... 200000 kgcm ² |

Swivel angle 180°

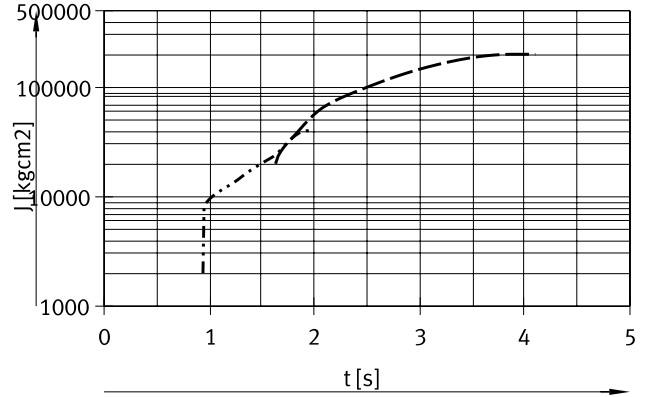

- | | | | |
|-------|------------------------|--------|--------------------------------------|
| | DRRD-50-...-Y9 (180°) | Ranges | → 2000 ... 40000 kgcm ² |
| ---- | DRRD-50-...-Y10 (180°) | | → 20000 ... 200000 kgcm ² |

Size 63 with cushioning Y9/Y10

Swivel angle 90°

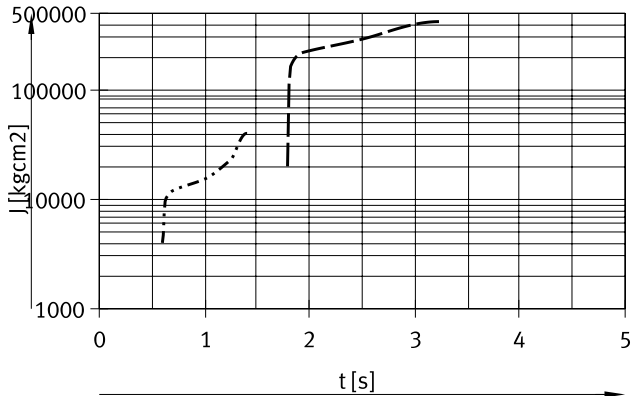

- | | | | |
|-------|-----------------------|--------|--------------------------------------|
| | DRRD-63-...-Y9 (90°) | Ranges | → 4000 ... 40000 kgcm ² |
| ---- | DRRD-63-...-Y10 (90°) | | → 20000 ... 420000 kgcm ² |

Swivel angle 180°

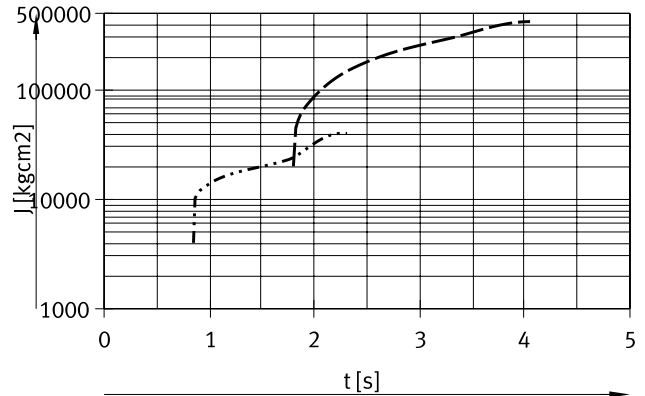

- | | | | |
|-------|------------------------|--------|--------------------------------------|
| | DRRD-63-...-Y9 (180°) | Ranges | → 4000 ... 40000 kgcm ² |
| ---- | DRRD-63-...-Y10 (180°) | | → 20000 ... 420000 kgcm ² |

Data sheet

Max. permissible mass moment of inertia J at the flange shaft as a function of swivel time t (at room temperature and an operating pressure of 6 bar)

Size 16 with cushioning Y12
Swivel angle 90°/180°

Size 20 with cushioning Y12

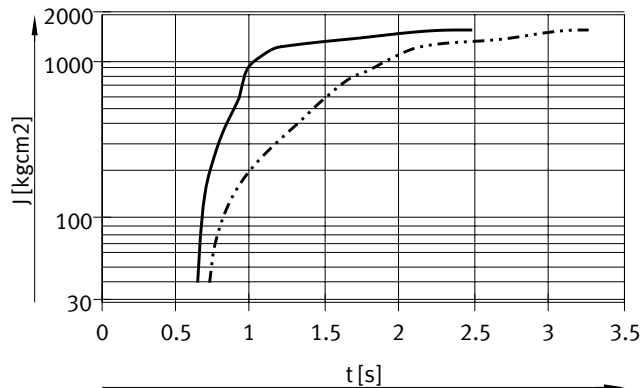
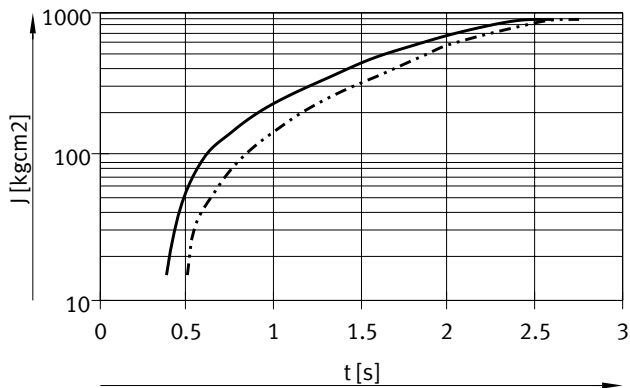

— DRRD-16-...-Y12 (90°) → 15 ... 900 kgcm²
 - - - DRRD-16-...-Y12 (180°) → 15 ... 900 kgcm²

— DRRD-20-...-Y12 (90°) → 40 ... 1600 kgcm²
 - - - DRRD-20-...-Y12 (180°) → 40 ... 1600 kgcm²

Size 25 with cushioning Y12
Swivel angle 90°/180°

Size 32 with cushioning Y12

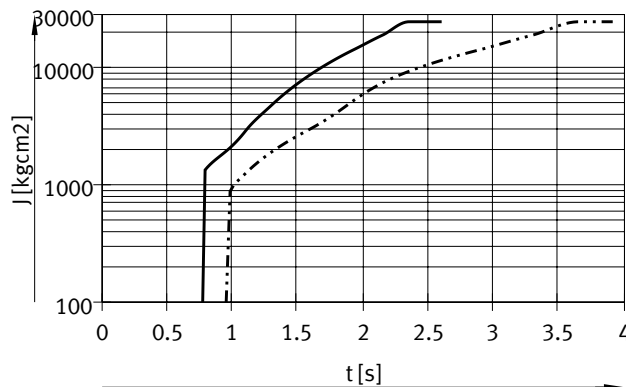
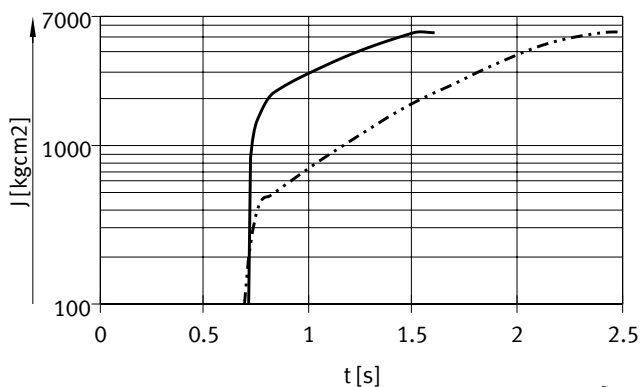

— DRRD-25-...-Y12 (90°) → 100 ... 5500 kgcm²
 - - - DRRD-25-...-Y12 (180°) → 100 ... 5500 kgcm²

— DRRD-32-...-Y12 (90°) → 100 ... 26000 kgcm²
 - - - DRRD-32-...-Y12 (180°) → 100 ... 26000 kgcm²

Data sheet

Max. permissible mass moment of inertia J at the flange shaft as a function of swivel time t (at room temperature and an operating pressure of 6 bar)

Size 35 with cushioning Y12
Swivel angle 90°/180°

Size 40 with cushioning Y12

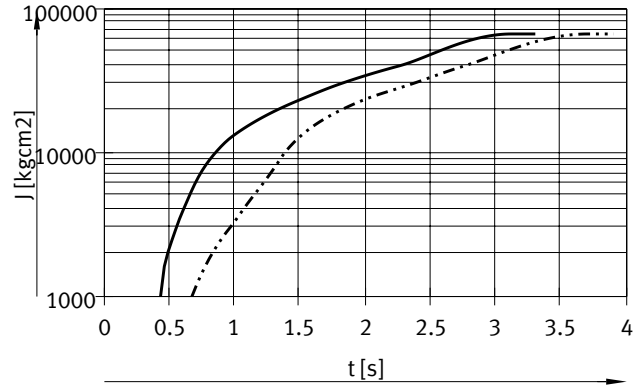
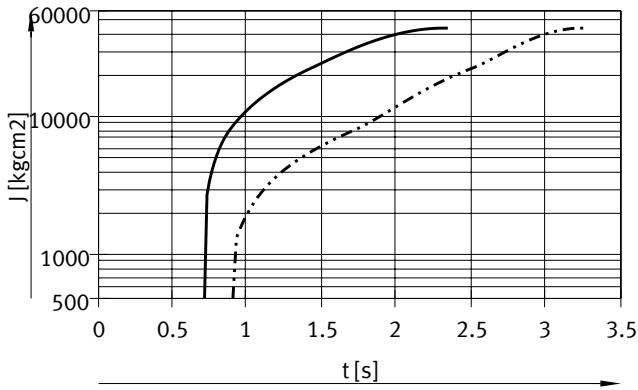

— DRRD-35-...-Y12 (90°) → 500 ... 45000 kgcm²
 - - - DRRD-35-...-Y12 (180°) → 500 ... 45000 kgcm²

— DRRD-40-...-Y12 (90°) → 1000 ... 67000 kgcm²
 - - - DRRD-40-...-Y12 (180°) → 1000 ... 67000 kgcm²

Size 50 with cushioning Y12
Swivel angle 90°/180°

Size 63 with cushioning Y12

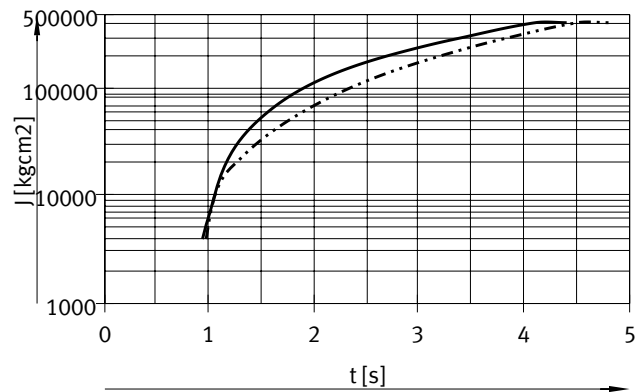
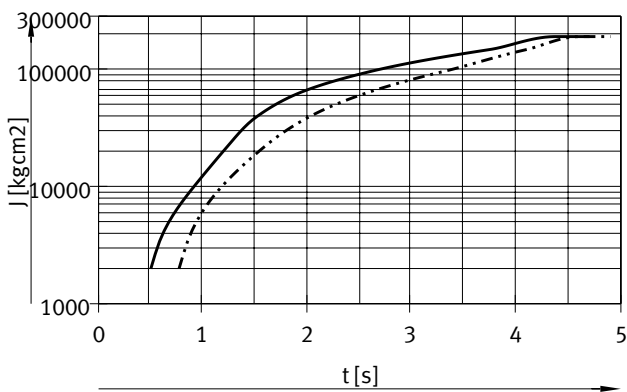

— DRRD-50-...-Y12 (90°) → 2000 ... 200000 kgcm²
 - - - DRRD-50-...-Y12 (180°) → 2000 ... 200000 kgcm²

— DRRD-63-...-Y12 (90°) → 4000 ... 420000 kgcm²
 - - - DRRD-63-...-Y12 (180°) → 4000 ... 420000 kgcm²

Data sheet

Max. dynamic load capacity at the flange shaft

The zero point for dimension Z is always the flange level of the basic drive, independently of the attachments (flange module).

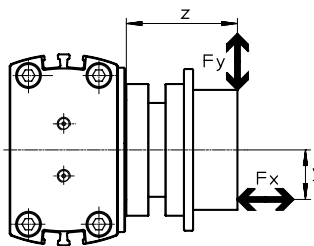
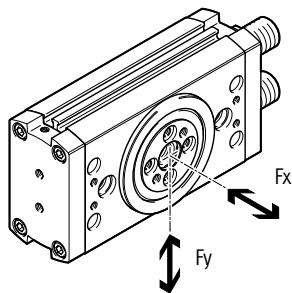

The following equation applies to combined loads (axial and radial):

$$\frac{F_y(z)}{F_{y\max.}(z)} + \frac{F_x(y)}{F_{x\max.}(y)} \leq 1$$

Max. dynamic radial force F_y as a function of distance z
Size 16/20

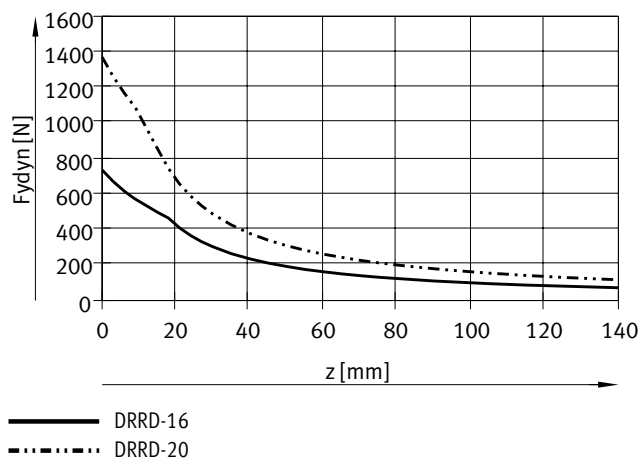

Size 25/32

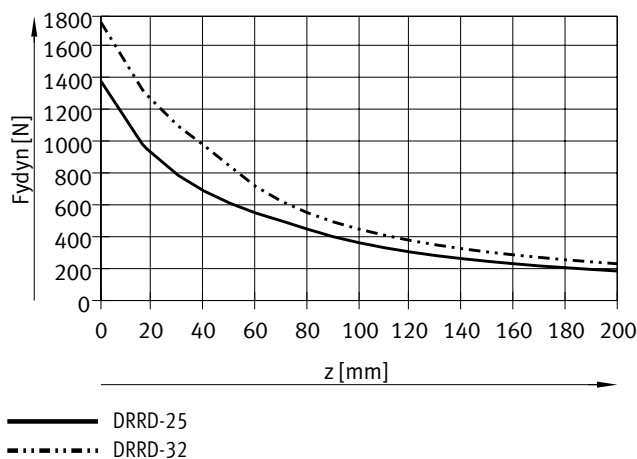

Size 35/40

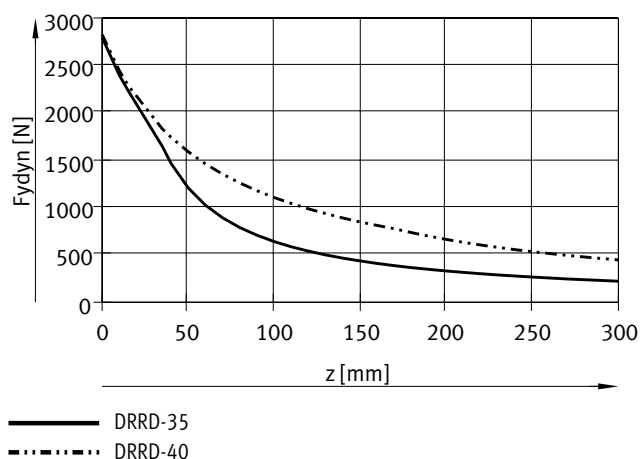

Size 50/63

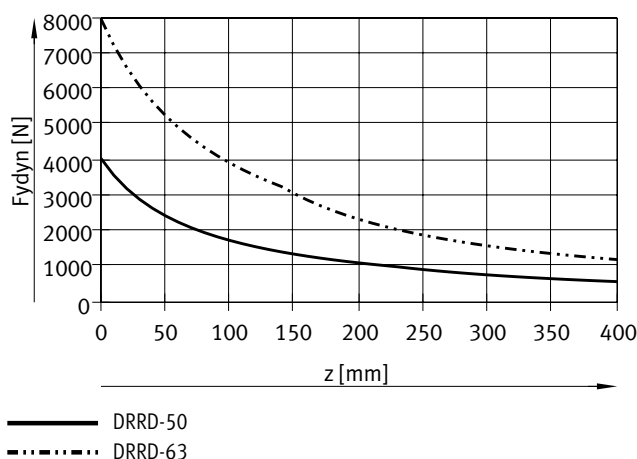

Data sheet

Max. dynamic load capacity at the flange shaft

The zero point for dimension Z is always the flange level of the basic drive, independently of the attachments (flange module).

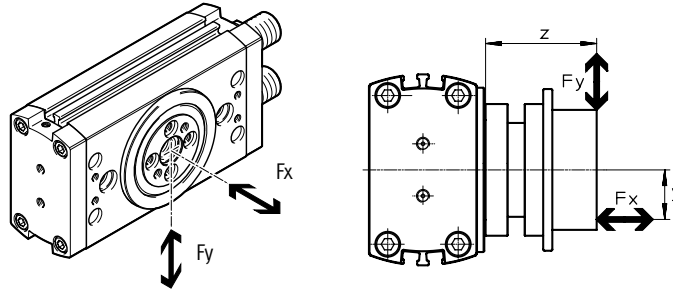

The following equation applies to combined loads (axial and radial):

$$\frac{F_{y(z)}}{F_{y \max. (z)}} + \frac{F_{x(y)}}{F_{x \max. (y)}} \leq 1$$

Max. dynamic radial force F_x as a function of distance y
Size 16/20

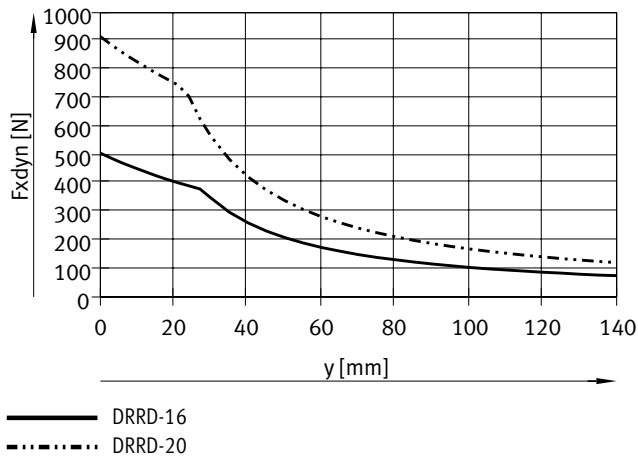

Size 25/32

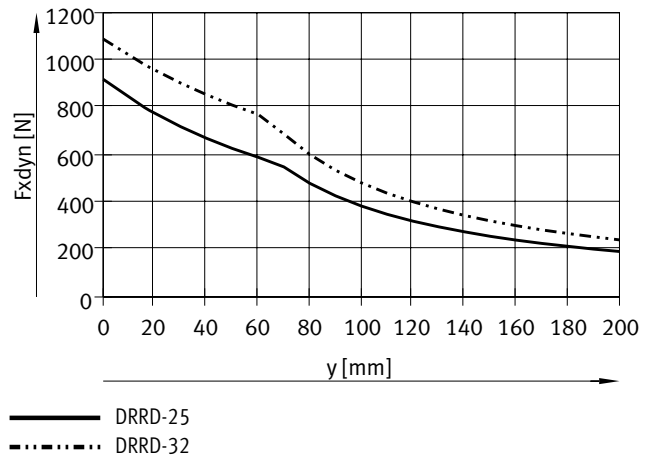

Size 35/40

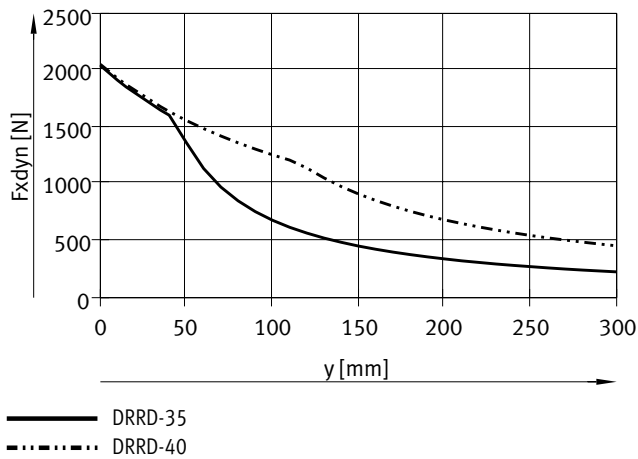

Size 50/63

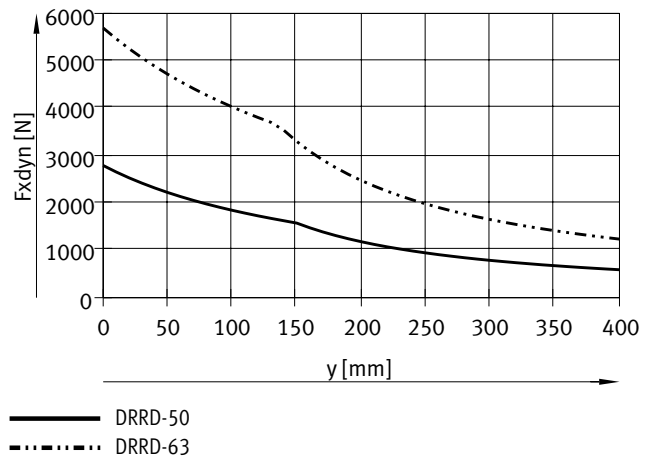

Data sheet

Max. static load capacity at the flange shaft

The zero point for dimension Z is always the flange level of the basic drive, independently of the attachments (flange module).

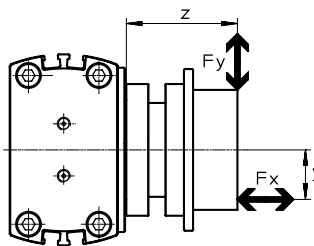
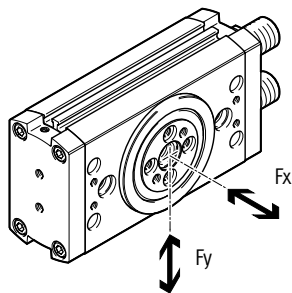

The following equation applies to combined loads (axial and radial):

$$\frac{F_y(z)}{F_{y\max.}(z)} + \frac{F_x(y)}{F_{x\max.}(y)} \leq 1$$

Max. static radial force F_y as a function of distance z

Size 16/20

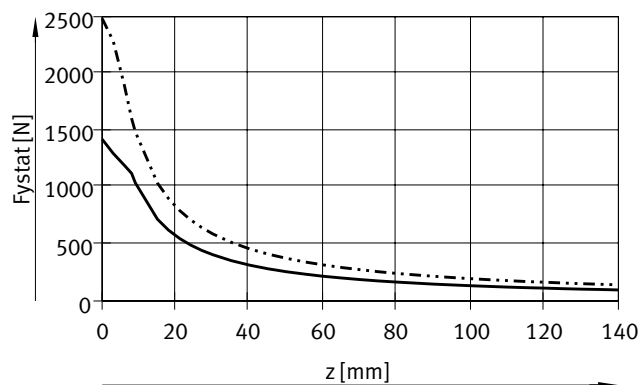

— DRRD-16
- - - DRRD-20

Size 25/32

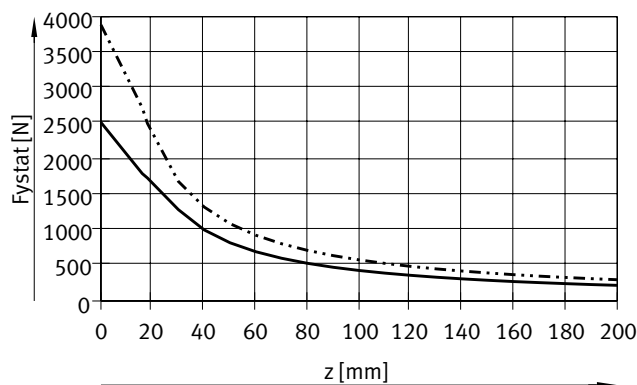

— DRRD-25
- - - DRRD-32

Size 35/40

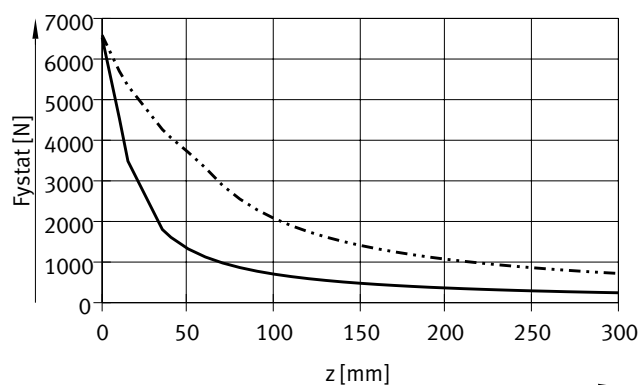

— DRRD-35
- - - DRRD-40

Size 50/63

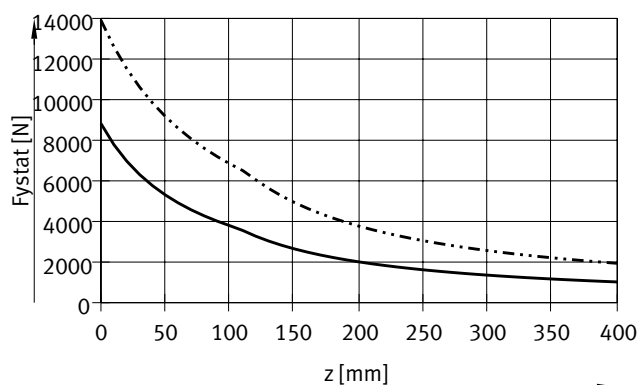

— DRRD-50
- - - DRRD-63

Data sheet

Max. static load capacity at the flange shaft

The zero point for dimension Z is always the flange level of the basic drive, independently of the attachments (flange module).

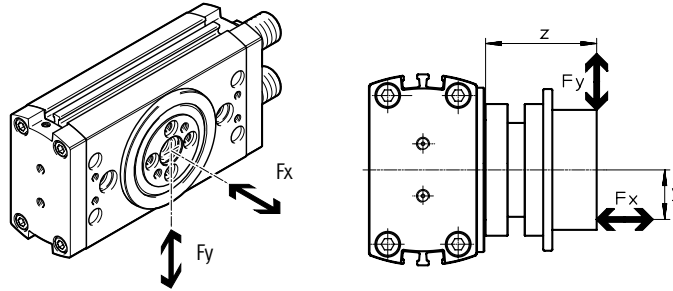

The following equation applies to combined loads (axial and radial):

$$\frac{F_y(z)}{F_{y \max. (z)}} + \frac{F_x(y)}{F_{x \max. (y)}} \leq 1$$

Max. static axial force F_x as a function of distance y
Size 16/20

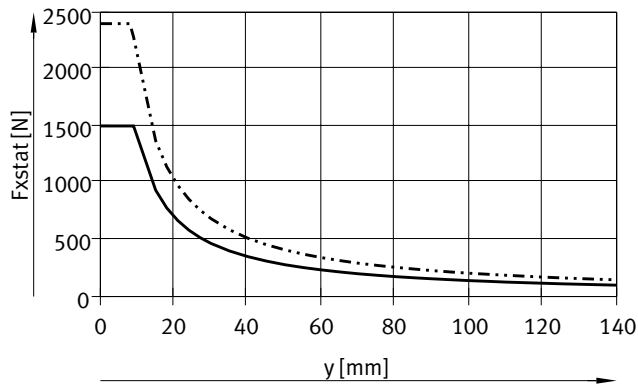

— DRRD-16
- - - DRRD-20

Size 25/32

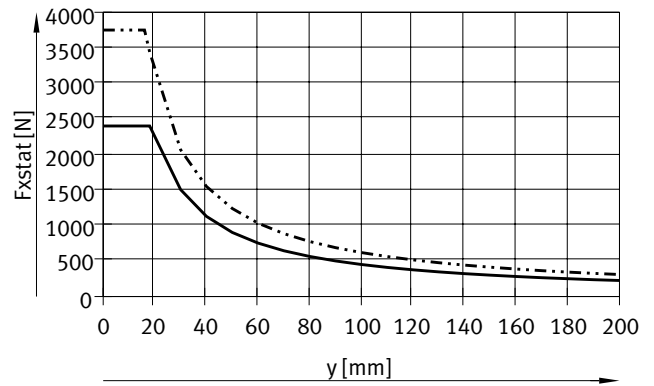

— DRRD-25
- - - DRRD-32

Size 35/40

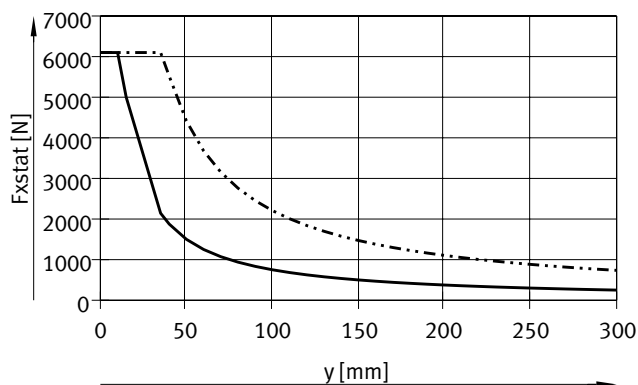

— DRRD-35
- - - DRRD-40

Size 50/63

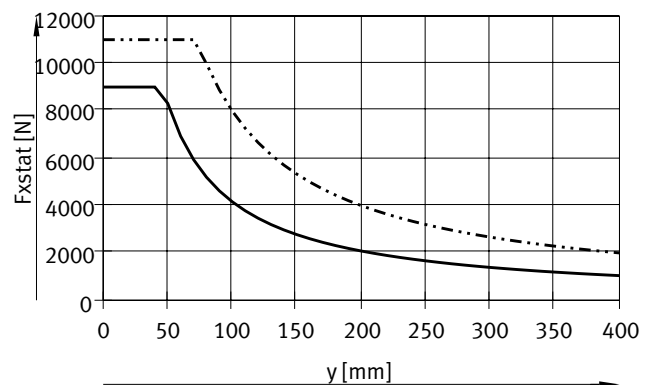

— DRRD-50
- - - DRRD-63

Data sheet

Max. load capacity on the drive shaft (DARF-Q11)

Max. radial forces F_y / axial forces F_x / bending moment M

- For the radial forces F_y , the limits of the flange shaft → page 32/34 and max. bending moment of the drive shaft apply → table below.
- The bending moment represents the load limit of the drive shaft and must not be exceeded.
- The zero point for dimension z is always the flange level of the basic drive, independently of the attachments (flange module).
- The axial force represents an additional load.

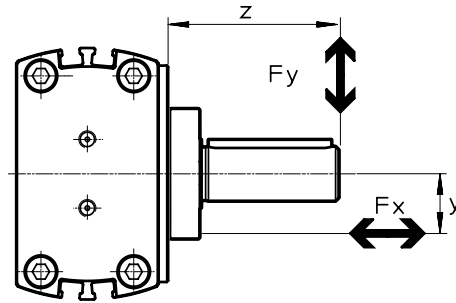
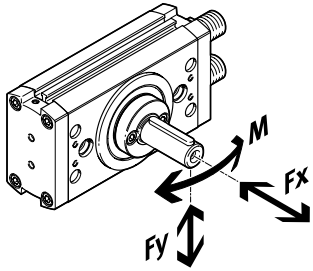

| Size | | 16 | 20 | 25 | 32 | 35 | 40 |
|--------------------|------|------|------|------|-----|-----|------|
| Axial force F_x | [N] | 625 | 625 | 625 | 900 | 900 | 2400 |
| Bending moment M | [Nm] | 13.5 | 14.4 | 34.4 | 63 | 63 | 84 |

Data sheet

Energy through-feed DRRD-...-P...E...



Function

The energy through-feed can be used to transfer electrical signals or compressed air through the hollow shaft.

Advantages

- Fast and easy supply of the parts connected to the flange (e.g. gripper)
- Tubing and electrical cables are not damaged by the rotation
- Two variants available:
 - Pneumatic
 - Pneumatic and electrical
- Different number of connections depending on the size

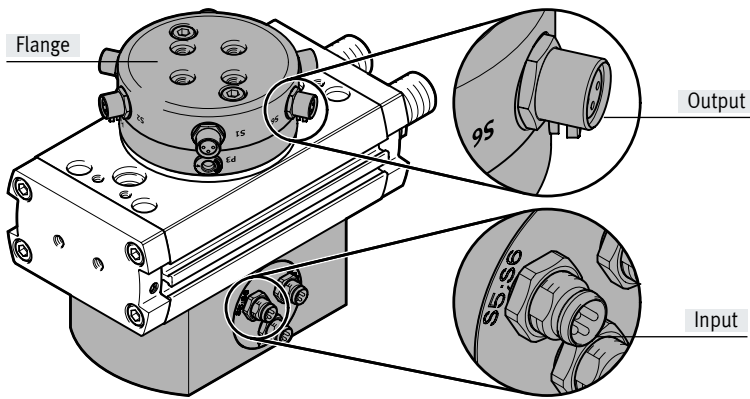

Note
Only connecting cables with straight connectors can be used (→ page 63).

Technical data

| Size | 16/20 | | 25/32/35 | | 40/50/63 | |
|-----------------------------------|-------------|--------------------------|-----------|--------------------------|-----------|--------------------------|
| Variant | Pneumatic | Pneumatic/ electrical | Pneumatic | Pneumatic/ electrical | Pneumatic | Pneumatic/ electrical |
| Order code | P2 | P2E2 | P4 | P4E6 | P8 | P8E8 |
| Pneumatic | | | | | | |
| Number of pneumatic ducts | 2 | 2 | 4 | 4 | 8 | 8 |
| Tubing O.D. | 4 | | | | | |
| Operating pressure per duct [bar] | -0.85 ... 8 | | | | | |
| Connection | M5 | | | | | |
| Flow rate per duct [l/min] | 86 | | | | 33 | |
| Electric | | | | | | |
| Number of electrical signals | - | 2 | - | 6 | - | 8 |
| Rated voltage [V DC] | - | 30 | - | 30 | - | 30 |
| Max. current ¹⁾ [A] | 1.5 | | | | | |
| Connection | M8 | | | | M12 | |

1) The positive and negative lines of all electrical connections are connected together. The combined maximum peak current for this common positive and negative line is also 1.5 A.

Note
Also approved for vacuum operation.

Data sheet

DRRD-...-P...E... – Energy through-feed

Pin allocation

Size 16/20

| Input Plug M8 | | | | Output M8 socket | | | |
|------------------|---------|-------------------|-----------------|---------------------|-------------------|---------|-------------|
| Designation | Signals | Pin ¹⁾ | Circuit diagram | Circuit diagram | Pin ¹⁾ | Signals | Designation |
| S1 | + | 1 | | | 1 3 4 | + | S1 |
| | - | 3 | | | | - | |
| | Sig 1 | 4 | | | | Sig 1 | |
| S2 | + | 1 | | | 1 3 4 | + | S2 |
| | - | 3 | | | | - | |
| | Sig 2 | 4 | | | | Sig 2 | |

1) Pin 1 (+) and Pin 3 (-) are connected to each other between plugs S1 and S2. Unused plugs and sockets should therefore be protected with the cover caps.

Size 25/32/35

| Input Plug M8 | | | | Output M8 socket | | | |
|------------------|---------|-------------------|-----------------|---------------------|-------------------|---------|-------------|
| Designation | Signals | Pin ¹⁾ | Circuit diagram | Circuit diagram | Pin ¹⁾ | Signals | Designation |
| S1;S2 | + | 1 | | | 1 3 4 | + | S1 |
| | Sig 2 | 2 | | | | - | |
| | - | 3 | | | | Sig 1 | |
| S3;S4 | + | 1 | | | 1 3 4 | + | S3 |
| | Sig 4 | 2 | | | | - | |
| | - | 3 | | | | Sig 3 | |
| S5;S6 | + | 1 | | | 1 3 4 | + | S5 |
| | Sig 6 | 2 | | | | - | |
| | - | 3 | | | | Sig 5 | |
| S5;S6 | + | 1 | | | 1 3 4 | + | S6 |
| | Sig 6 | 2 | | | | - | |
| | - | 3 | | | | Sig 5 | |

1) Pin 1 (+) and Pin 3 (-) are connected to each other between plugs S1 ... S6. Unused plugs and sockets should therefore be protected with the cover caps.

Data sheet

DRRD-...-P...E... – Energy through-feed

Size 40/50/63

| Input M12 plug | | | | Output M12 socket | | | |
|-------------------|--------------------------|-------------------|-----------------|----------------------|-------------------|--------------------------|-------------|
| Designation | Signals | Pin ¹⁾ | Circuit diagram | Circuit diagram | Pin ¹⁾ | Signals | Designation |
| S1;S2 | + Sig 2 - Sig 1 | 1 2 3 4 | | | 1 2 3 4 | + Sig 2 - Sig 1 | S1;S2 |
| S3;S4 | + Sig 4 - Sig 3 | 1 2 3 4 | | | 1 2 3 4 | + Sig 4 - Sig 3 | S3;S4 |
| S5;S6 | + Sig 6 - Sig 5 | 1 2 3 4 | | | 1 2 3 4 | + Sig 6 - Sig 5 | S5;S6 |
| S7;S8 | + Sig 8 - Sig 7 | 1 2 3 4 | | | 1 2 3 4 | + Sig 8 - Sig 7 | S7;S8 |

1) Pin 1 (+) and Pin 3 (-) are connected to each other between plugs S1 ... S8. Unused plugs and sockets should therefore be protected with the cover caps.

Data sheet

Intermediate position DRRD-...-PS1



Function

The intermediate-position module enables an additional position to be set, at half of the nominal rotation angle (90°).

A piston with two screwed-in guide systems is supplied with compressed air and moves the gear racks of the unpressurised semi-rotary drive until both pistons rest on the plungers positioned in the guide systems and are held in this position. The movement is cushioned using a shock absorber.

To move to the other end position, the semi-rotary drive is pressurised with compressed air. The piston of the basic drive thus moves the entire intermediate-position piston back into its initial position.

Characteristics

- Setting range: $90^\circ \pm 10^\circ$
- Cushioning variants: P, Y9
- Can be approached and travelled through from both end positions
- Position sensing of the intermediate position possible

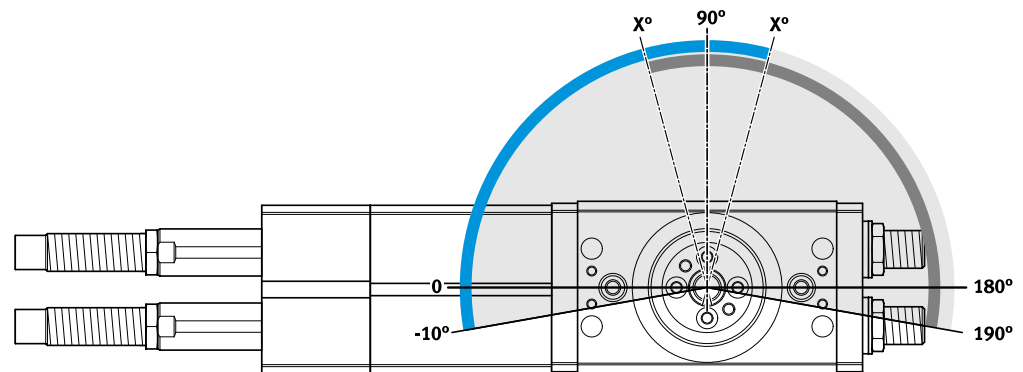

Setting the swivel speed

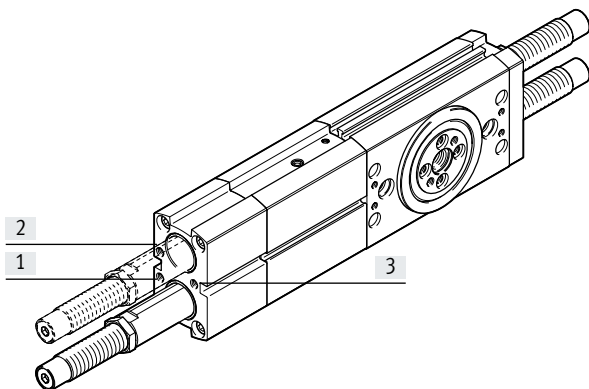

Semi-rotary drive and intermediate-position module must only be operated with controlled air flow. The flow control should be connected as close as possible to the semi-rotary drive (e.g. one-way flow control valve GRLA-...) → page 64.

In the event of pressure failure, the payload may hit an end position in an uncontrolled manner. In order to prevent this, piloted check valves HGL or an air reservoir VZS are recommended → page 64.

The following movements are adjusted using the supply ports [1] and [2]: end position → intermediate position

Both directions can be adjusted separately from each other.

The following movement is adjusted via supply port [3]:

Intermediate position → end position

Both directions are set simultaneously.

Data sheet

DRRD-...-PS1 – Intermediate position

Swivel angle adjustment

By pushing the shock absorber as far as the stop, the flange shaft of the semi-rotary drive rotates into the intermediate position.

In delivered state, the intermediate position is set to 90°. By screwing in or

unscrewing the shock absorbers, the swivel angle can be adjusted by ±10°.

If the setting dimension X_{max} is exceeded, the shock absorber can no longer completely cushion the movement.

If the setting dimension X_{min} is not reached, the shock absorber not only

cushions the intermediate position, but also the end position of the semi-rotary drive.

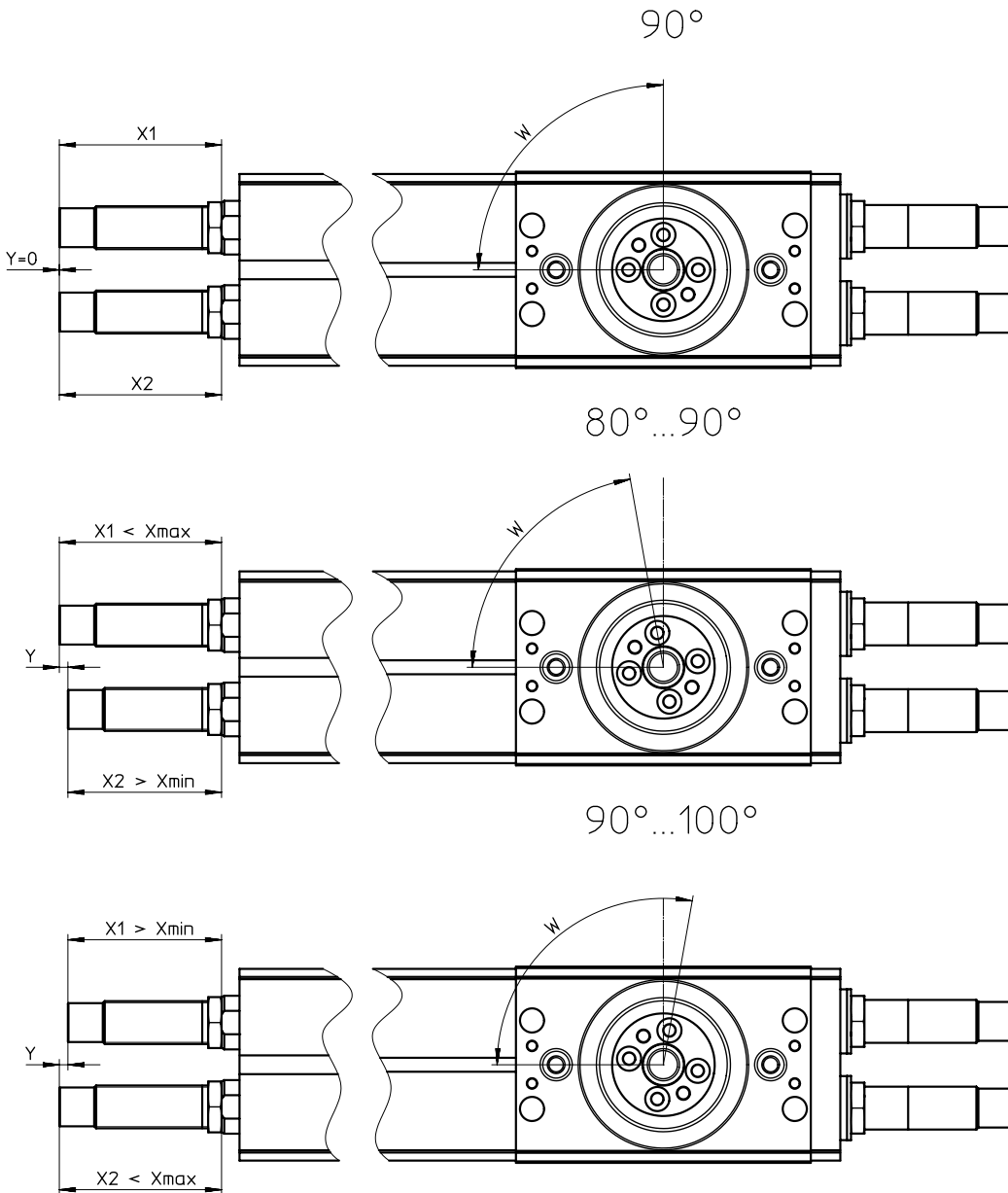

| Size | | 16 | 20 | 25 | 32 | 35 | 40 | 50 | |
|--|------|------|------|------|------|------|------|-----|---|
| Setting dimension X | | | | | | | | | |
| DRRD-...-P | | | | | | | | | |
| X_{min} | [mm] | 7.7 | 14.9 | 14.2 | 12.5 | - | - | - | |
| X_{max} | [mm] | 10.1 | 17.8 | 20.6 | 23.2 | - | - | - | |
| DRRD-...-Y9 | | | | | | | | | |
| X_{min} | [mm] | 29.6 | 41.8 | 56.9 | 70.3 | 88.6 | 86.7 | 114 | |
| X_{max} | [mm] | 32 | 44.5 | 60.4 | 78.5 | 96.2 | 92.7 | 128 | |
| Dimension Y for 10° change in the swivel angle | | [mm] | 2.3 | 2.4 | 3.2 | 3.7 | 3.7 | 5.6 | 8 |

Data sheet

DRRD-...-PS1 – Intermediate position

Control variants

Circuit diagram

[1] With 1x 5/3-way valve and 1x 3/2-way valve

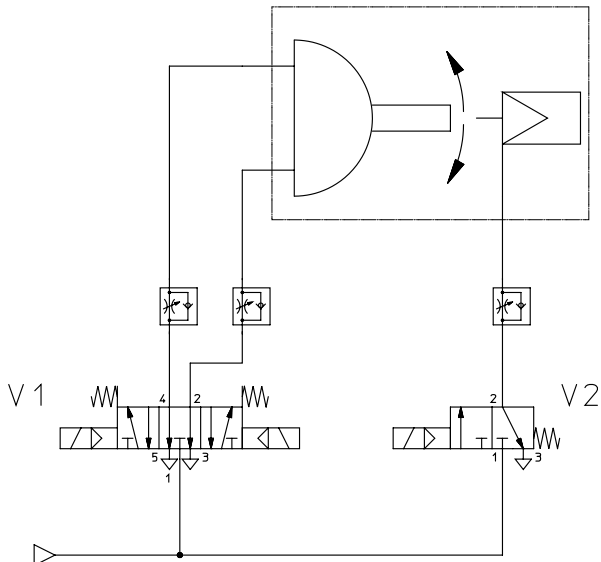

Control sequence

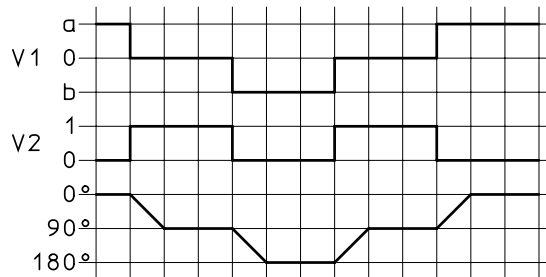

[2] With 3x 3/2-way valves

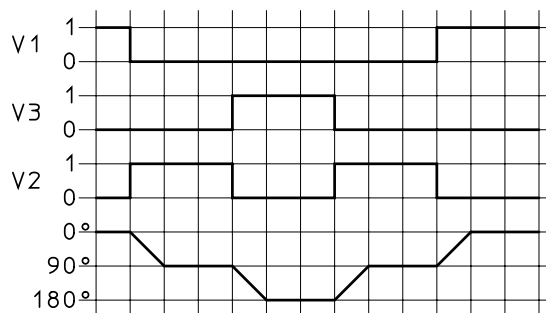
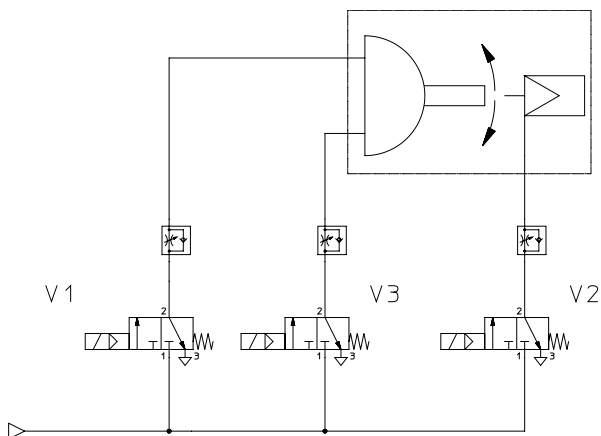

[3] With 1x 5/3-way valve and 3x 3/2-way valve

The exhaust air flow control valves for the basic drive can be adjusted separately here.

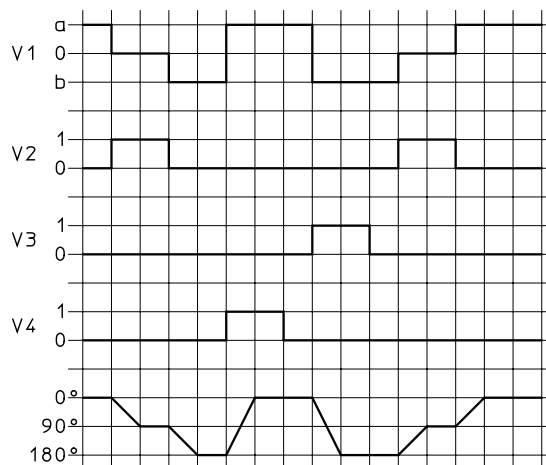
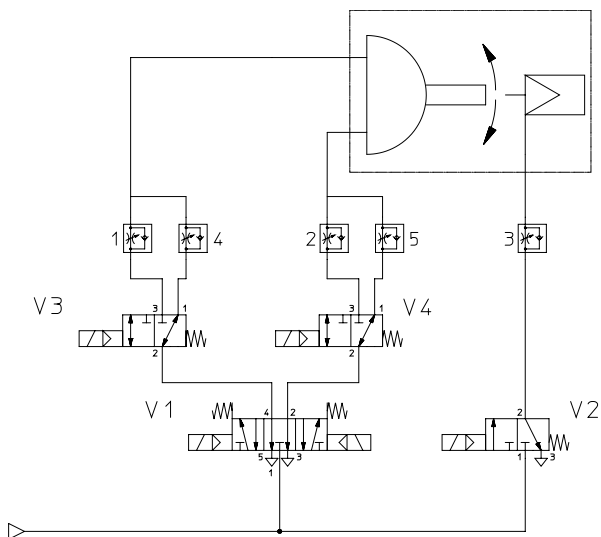

Data sheet

DRRD-...-PS1 – Intermediate position

Max. permissible mass moment of inertia J at the flange shaft as a function of swivel time t
(at room temperature and an operating pressure of 6 bar)

Size 16

End position to intermediate position

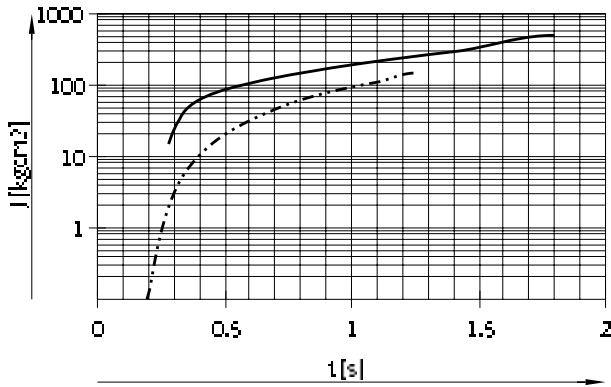

— DRRD-16-...-Y9-PS1 → 15 ... 500 kgcm²
 - · - · - · DRRD-16-P-PS1 → 0 ... 150 kgcm²

Intermediate position to end position

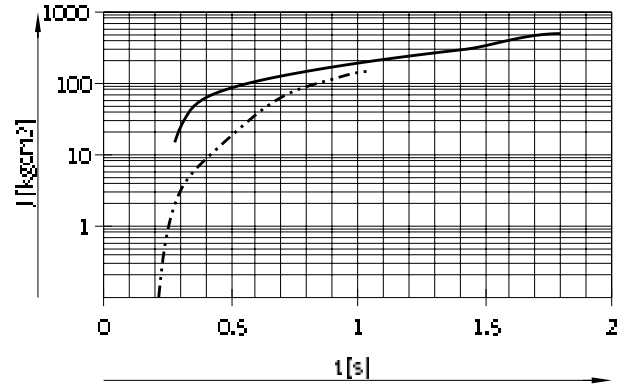

— DRRD-16-...-Y9-PS1 → 15 ... 500 kgcm²
 - · - · - · DRRD-16-P-PS1 → 0 ... 150 kgcm²

Size 20

End position to intermediate position

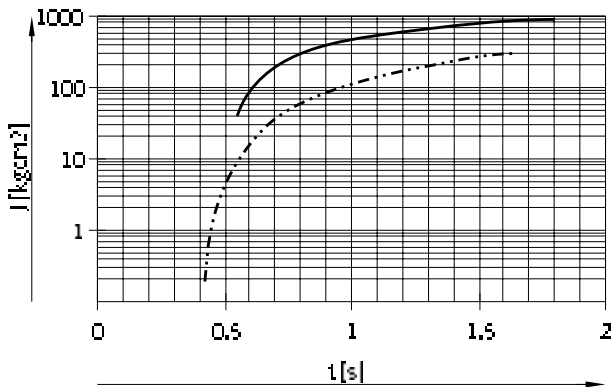

— DRRD-20-...-Y9-PS1 → 40 ... 900 kgcm²
 - · - · - · DRRD-20-P-PS1 → 0 ... 300 kgcm²

Intermediate position to end position

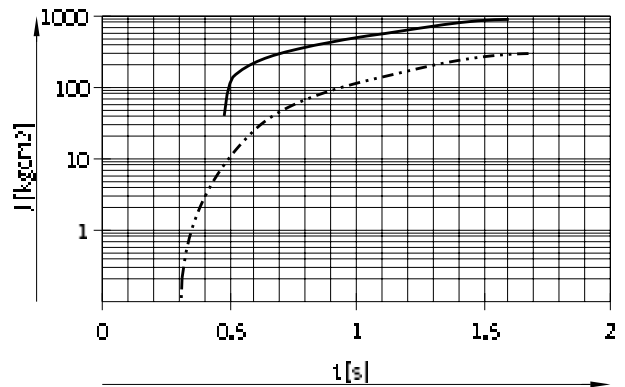

— DRRD-20-...-Y9-PS1 → 40 ... 900 kgcm²
 - · - · - · DRRD-20-P-PS1 → 0 ... 300 kgcm²

Size 25

End position to intermediate position

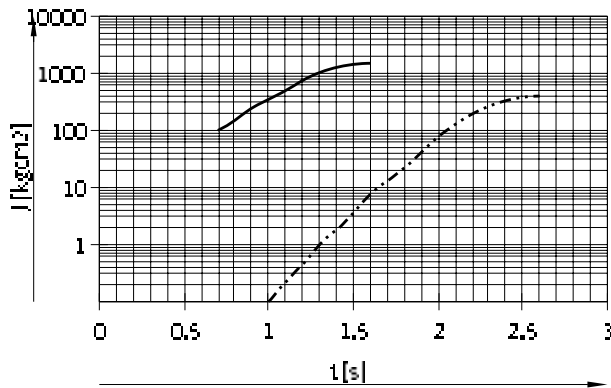

— DRRD-25-...-Y9-PS1 → 100 ... 1500 kgcm²
 - · - · - · DRRD-25-P-PS1 → 0 ... 400 kgcm²

Intermediate position to end position

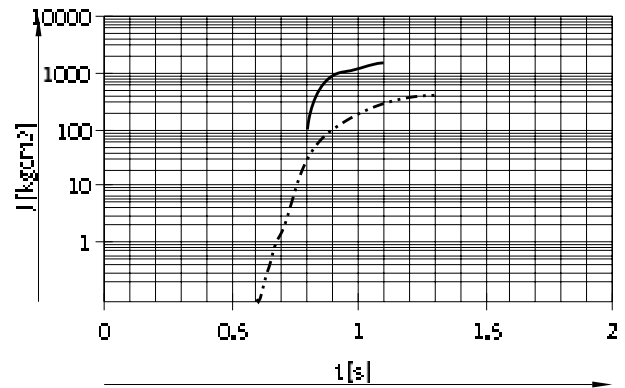

— DRRD-25-...-Y9-PS1 → 100 ... 1500 kgcm²
 - · - · - · DRRD-25-P-PS1 → 0 ... 400 kgcm²

Data sheet

DRRD-...-PS1 – Intermediate position

Max. permissible mass moment of inertia J at the flange shaft as a function of swivel time t

(at room temperature and an operating pressure of 6 bar)

Size 32

End position to intermediate position

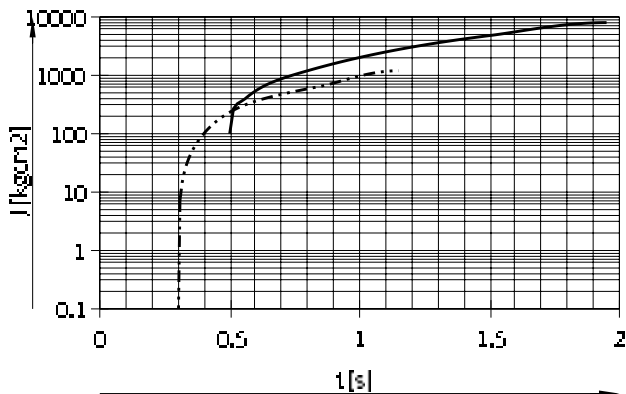

— DRRD-32-...-Y9-PS1 Ranges
 → 100 ... 8000 kgcm²
 - - - - - DRRD-32-P-PS1 → 0 ... 500 kgcm²

Intermediate position to end position

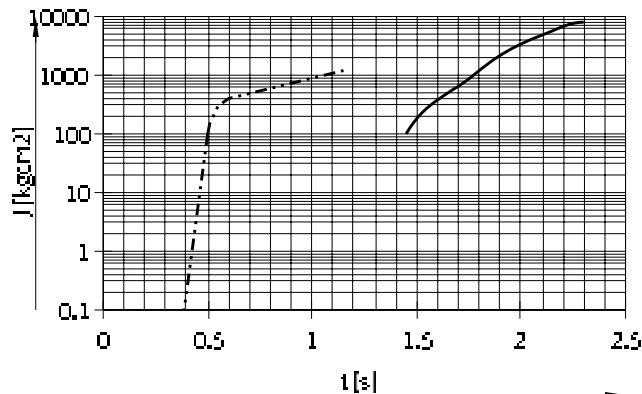

— DRRD-32-...-Y9-PS1 Ranges
 → 100 ... 8000 kgcm²
 - - - - - DRRD-32-P-PS1 → 0 ... 500 kgcm²

Size 35

End position to intermediate position

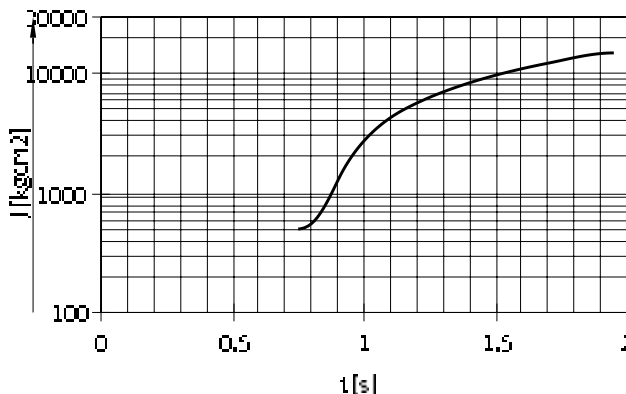

— DRRD-35-...-Y9-PS1 Ranges
 → 500 ... 15000 kgcm²

Intermediate position to end position

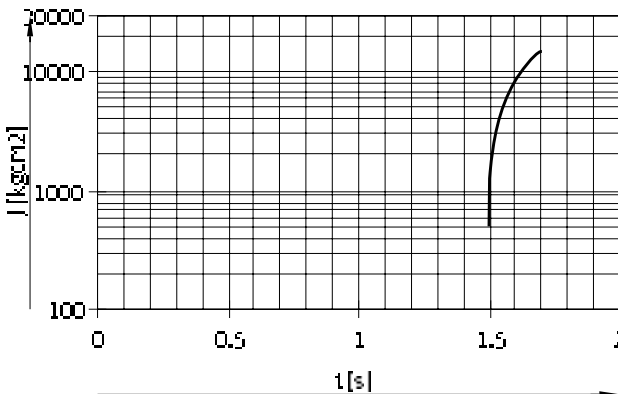

— DRRD-35-...-Y9-PS1 Ranges
 → 500 ... 15000 kgcm²

Data sheet

DRRD-...-PS1 – Intermediate position
 Max. permissible mass moment of inertia J at the flange shaft as a function of swivel time t
 (at room temperature and an operating pressure of 6 bar)

Size 40

End position to intermediate position

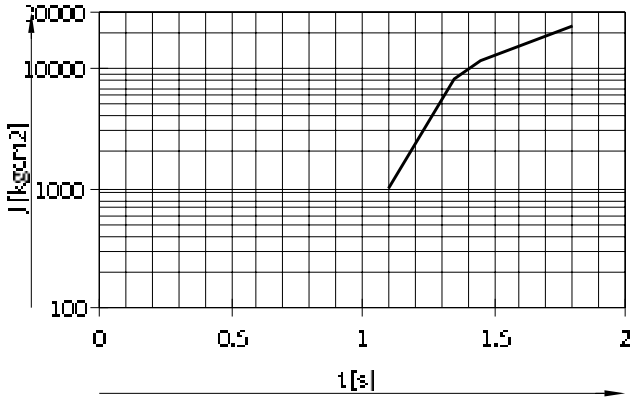

DRRD-40-...-Y9-PS1 Ranges → 1000 ... 23000 kgcm²

Intermediate position to end position

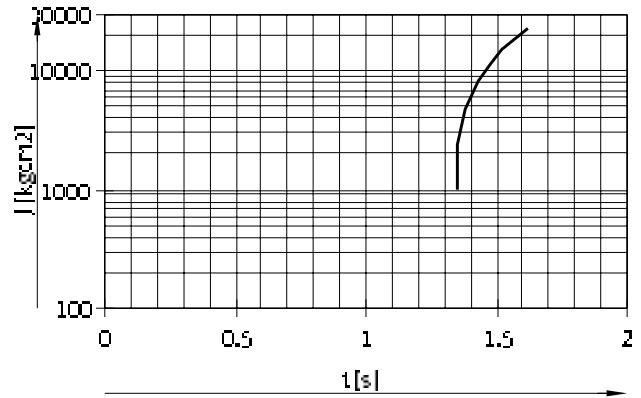

DRRD-40-...-Y9-PS1 Ranges → 1000 ... 23000 kgcm²

Size 50

End position to intermediate position

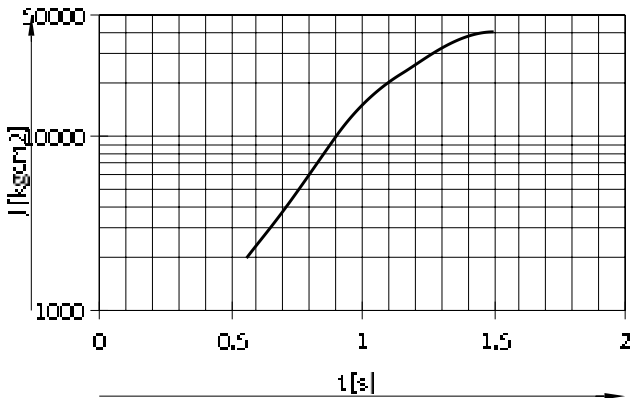

DRRD-50-...-Y9-PS1 Ranges → 2000 ... 40000 kgcm²

Intermediate position to end position

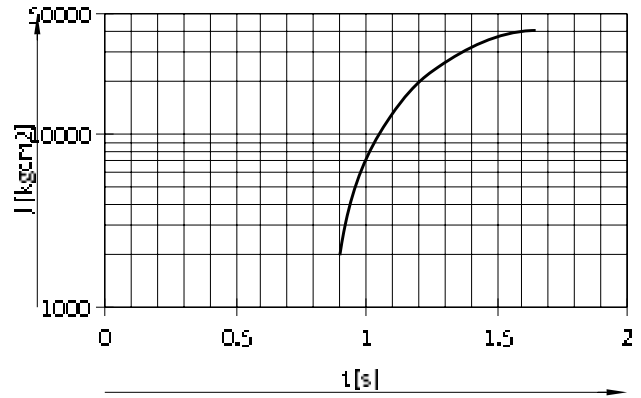

DRRD-50-...-Y9-PS1 Ranges → 2000 ... 40000 kgcm²

Data sheet

Dimensions

Download CAD data → www.festo.com

The semi-rotary drive must only be operated with controlled air flow. The flow control should be connected as close as possible to the semi-rotary drive (e.g. one-way flow control valve GRLA-...) → page 64.

Illustrated position of the flange shaft corresponds to the mid-position (swivel angle 90°).

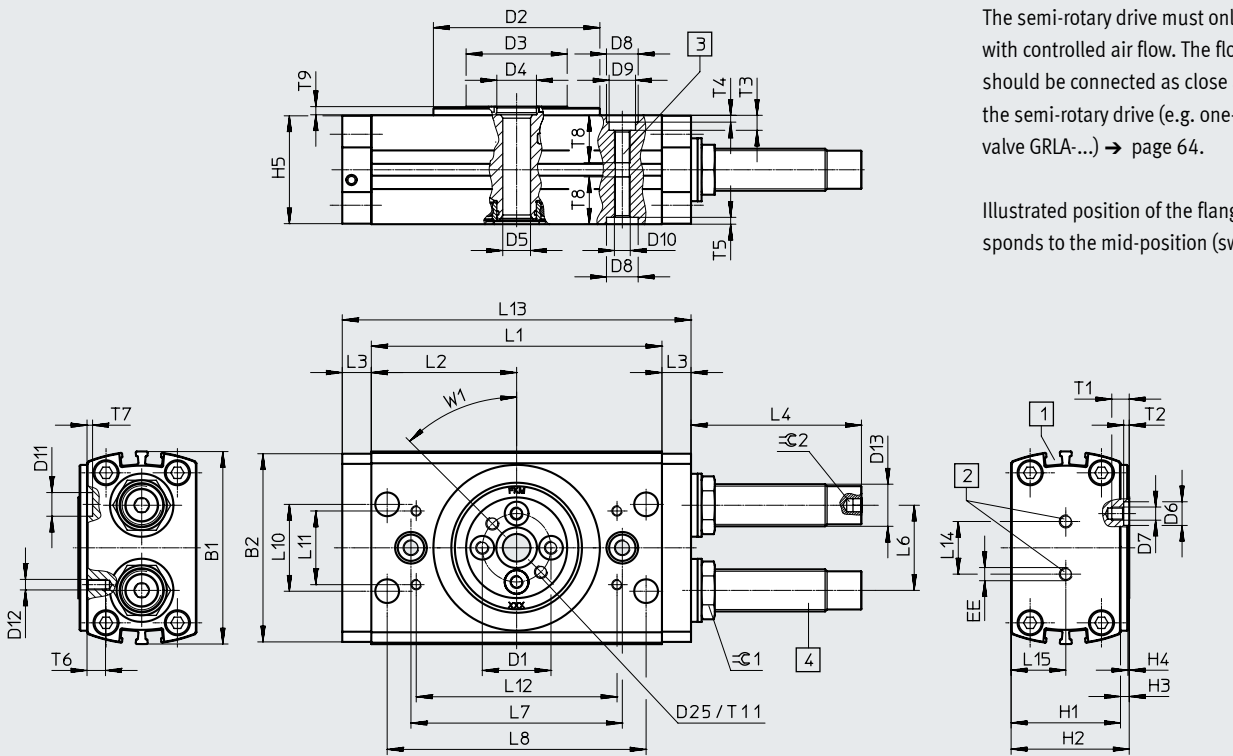

DRRD-32 ... -40

DRRD- ... -P

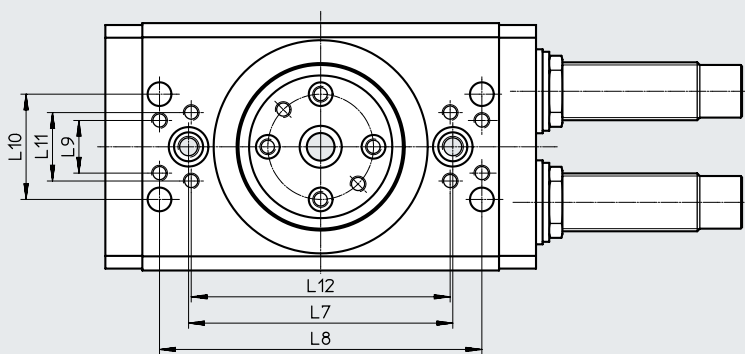

DRRD-50/63

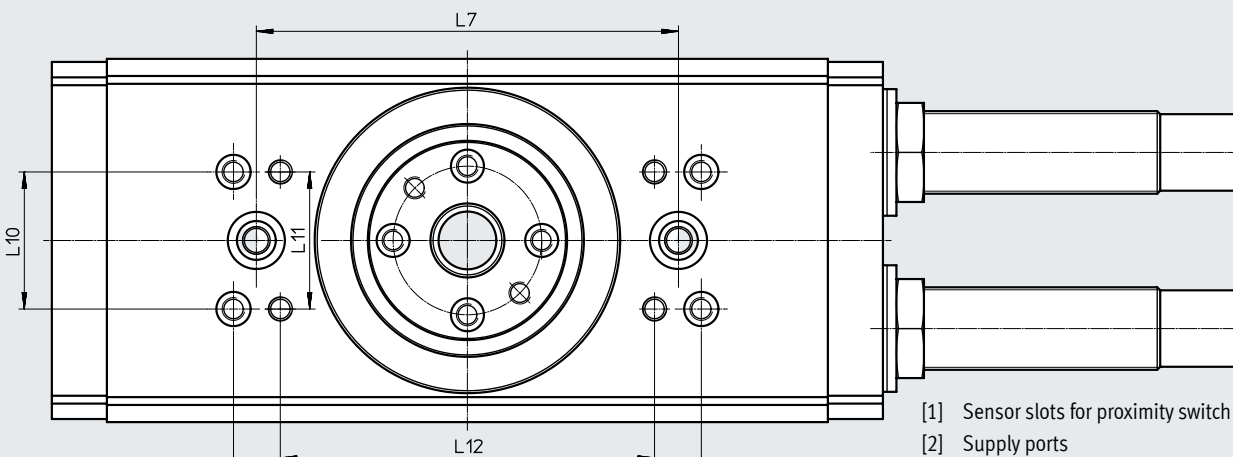
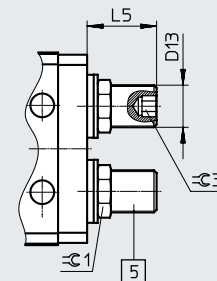

- [1] Sensor slots for proximity switch
- [2] Supply ports
- [3] Mounting thread
- [4] Shock absorber (DRRD-...-Y9/-Y10/-Y14)
- [5] Cushioning elements (DRRD-...-P)

Data sheet

| Size | B1 ±0.25 | B2 | D1 ∅ ±0.025 | D2 ∅ +0/-0.05 | D3 ∅ | D4 ∅ H7 | D5 ∅ +0.15/-0.05 | D6 ∅ H7 | D7 | D8 ∅ H7 | D9 ∅ | D10 |
|------|-------------|-------|-------------------|---------------------|---------|---------------|------------------------|---------------|-----|---------------|---------|-----|
| 16 | 58 | 56.2 | 21 | 50 | 32 | 12 | 8 | 7 | M4 | 9 | 8 | M5 |
| 20 | 65 | 63.4 | 24 | 56 | 34.9 | 12 | 8 | 7 | M4 | 9 | 8 | M5 |
| 25 | 73.2 | 71.5 | 26 | 63 | 38.25 | 15 | 10.5 | 9 | M5 | 12 | 10 | M6 |
| 32 | 94 | 92.6 | 40 | 81 | 54.2 | 15 | 10.5 | 9 | M6 | 15 | 11 | M8 |
| 35 | 106 | 104 | 45 | 91 | 59.9 | 25 | 10.5 | 9 | M6 | 15 | 11 | M8 |
| 40 | 113 | 111 | 45 | 91 | 59.9 | 25 | 21 | 9 | M6 | 15 | 14 | M10 |
| 50 | 132 | 129.9 | 54 | 110 | 73 | 25 | 21 | 12 | M8 | 15 | 14 | M10 |
| 63 | 159 | 157 | 63 | 135 | 82.8 | 25 | 21 | 15 | M10 | 25 | 17 | M12 |

| Size | D11 ∅ H7 | D12 | D13 | D25 | H1 ±0.1 | H2 +0.2/-0.1 | H3 +0.3/-0.2 | H4 ±0.1 | H5 | L1 ±0.1 | L2 | L3 ±0.1 |
|------|----------------|-----|---------|-----|------------|-----------------|-----------------|------------|------|------------|-------|------------|
| 16 | 7 | M3 | M10x1 | M4 | 33 | 35.6 | 2.6 | 0.5 | 32.6 | 84 | 42 | 10.5 |
| 20 | 9 | M4 | M12x1 | M5 | 36 | 39.6 | 3.6 | 0.5 | 35.6 | 86 | 43 | 11 |
| 25 | 9 | M4 | M16x1 | M5 | 41.4 | 44.7 | 3.3 | 0.5 | 41 | 110 | 55 | 11 |
| 32 | 9 | M6 | M22x1.5 | M6 | 50 | 55.5 | 5.5 | 1 | 49.6 | 135 | 67.5 | 14 |
| 35 | 9 | M6 | M26x1.5 | M6 | 63 | 67 | 4 | 1 | 62.2 | 148 | 74 | 15 |
| 40 | 9 | M6 | M26x1.5 | M6 | 68 | 72 | 4 | 1 | 67.2 | 199 | 99.5 | 15 |
| 50 | 15 | M8 | M30x1.5 | M8 | 78 | 83 | 5 | 1 | 77.2 | 262 | 131 | 20 |
| 63 | 15 | M10 | M37x1.5 | M10 | 100 | 107 | 7 | 2 | 99.2 | 335 | 167.5 | 25 |

| Size | L6 | L7 ±0.02 | L8 ±0.2 | L9 ±0.15 | L10 ±0.02 | L11 ±0.15 | L12 ±0.2 | L13 | L14 | L15 | T1 | T2 +0.1 |
|------|-------|-------------|------------|-------------|--------------|--------------|-------------|-----|-----|------|------|------------|
| 16 | 23.2 | 64 | 74 | - | 26 | 22 | 61 | 105 | 20 | 16.3 | 5.6 | 1.6 |
| 20 | 26 | 70 | 74 | - | 33 | 14 | 80 | 108 | 20 | 17.8 | 6 | 1.6 |
| 25 | 32.25 | 80 | 98 | - | 33 | 14 | 98 | 132 | 20 | 20.5 | 6.6 | 2.1 |
| 32 | 42.2 | 100 | 122 | 20 | 40 | 26 | 98 | 163 | 30 | 24.8 | 8 | 2.1 |
| 35 | 49.6 | 120 | 130 | 44 | 26 | 44 | 105 | 178 | 42 | 31.1 | 8 | 2.1 |
| 40 | 56 | 120 | 130 | 44 | 26 | 44 | 105 | 229 | 42 | 33.6 | 8 | 2.1 |
| 50 | 64 | 160 | 160 | 34 | 34 | 54 | 132 | 302 | 50 | 39 | 10.6 | 2.6 |
| 63 | 78 | 170 | 190 | 60 | 60 | 60 | 149 | 385 | 50 | 49.6 | 14 | 3.1 |

| Size | T3 | T4 +0.1 | T5 +0.1 | T6 | T7 +0.1 | T8 | T9 +0.1 | T11 | EE | W1 | ≈ 1 | ≈ 2 | ≈ 3 |
|------|-----|------------|------------|------|------------|------|------------|-----|------|-----|-----|-----|-----|
| 16 | 4.7 | 2.1 | 2.1 | 6.3 | 1.6 | 15 | 2.6 | 5.6 | M5 | 45° | 13 | 3 | 5 |
| 20 | 4.7 | 2.1 | 2.1 | 6.3 | 2.1 | 15 | 2.6 | 5.6 | M5 | 45° | 15 | 4 | 6 |
| 25 | 5.7 | 2.6 | 2.6 | 7 | 2.1 | 18 | 3.1 | 5.5 | M5 | 45° | 19 | 5 | 8 |
| 32 | 6.5 | 3.1 | 3.1 | 7.8 | 2.1 | 23.1 | 3.1 | 8 | G1/8 | 45° | 27 | 5 | 10 |
| 35 | 6.5 | 3.1 | 3.1 | 8.5 | 2.1 | 22.6 | 3.5 | 8 | G1/8 | 45° | 32 | 6 | 10 |
| 40 | 8.6 | 3.1 | 3.1 | 9 | 2.1 | 32 | 3.5 | 8 | G1/8 | 45° | 32 | 6 | 10 |
| 50 | 8.6 | 3.1 | 3.1 | 10.5 | 3.1 | 30 | 3.5 | 10 | G1/4 | 45° | 36 | 8 | - |
| 63 | 11 | 3.5 | 3.5 | 14 | 3.1 | 40 | 3.5 | 14 | G3/8 | 45° | 46 | 8 | - |

| Size | Dimension with 180° swivel angle | | Swivel angle adjustment range | | |
|------|----------------------------------|------|-------------------------------|-----------------|-------------|
| | L4 | L5 | L4 min./max. | L5 min./max. | 1 mm = ...° |
| 16 | 37 | 17.6 | -20/+1.5 | -12/+1.4 | 8.7 |
| 20 | 41.8 | 18 | -21.1/+1.5 | -11/+1.4 | 9 |
| 25 | 63 | 24.3 | -28.9/+1.9 | -15/+1.8 | 6.6 |
| 32 | 78.3 | 29.5 | -34.7/+2.4 | -19/+2.3 | 5.6 |
| 35 | 97.5 | 40.9 | -34.7/+2.4 | -27/+2.3 | 5.6 |
| 40 | 98.2 | 41.6 | -53/+3.2 | -28/+3.1 | 3.6 |
| 50 | 126 | - | -74.5/+4.4 | - | 2.6 |
| 63 | 120 | - | -71.7/+7.1 | - | 1.9 |

Data sheet

Dimensions – Variants

Download CAD data → www.festo.com

P... – Energy through-feed, pneumatic

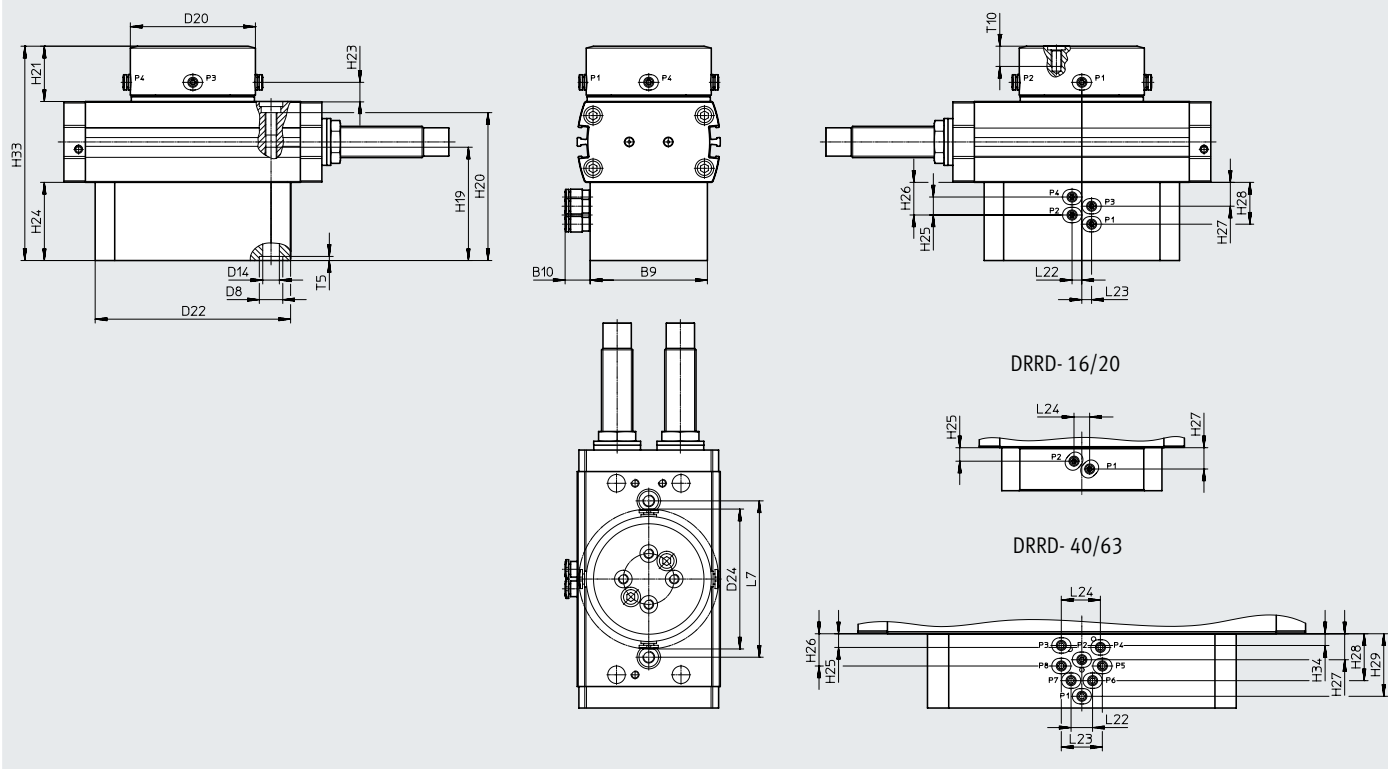

| Size | B9 | B10 | D8 ø H7 | D14 ø | D20 ø | D22 ø |
|------|----|------|---------------|----------|----------|----------|
| 16 | 52 | 13.4 | 9 | 6 | 54 | 82 |
| 20 | 58 | 13.4 | 9 | 6 | 54 | 82 |
| 25 | 60 | 12.8 | 12 | 6.5 | 64 | 100 |
| 32 | 70 | 12.8 | 15 | 8.5 | 64 | 120 |
| 35 | 80 | 12.8 | 15 | 8.5 | 64 | 138 |
| 40 | 80 | 13.4 | 15 | 11 | 89 | 158 |
| 50 | 80 | 13.4 | 15 | 11 | 89 | 190 |
| 63 | 80 | 13.4 | 25 | 13 | 89 | 210 |

| Size | D24 ø | H19 | H20 | H21 | H23 | H24 |
|------|----------|------|-------|------|------|-----|
| 16 | 70 | 43 | 56.4 | 16.6 | 7.6 | 22 |
| 20 | 70 | 43 | 59.3 | 17.6 | 8.6 | 22 |
| 25 | 71.6 | 57 | 74.7 | 28.3 | 9.8 | 40 |
| 32 | 71.6 | 62 | 82.4 | 31.5 | 12 | 40 |
| 35 | 71.6 | 61.6 | 95.5 | 30 | 10.5 | 40 |
| 40 | 96.9 | 70 | 97.4 | 21 | 10.5 | 38 |
| 50 | 96.9 | 68 | 107.4 | 24 | 11.5 | 38 |
| 63 | 96.9 | 78 | 127 | 29 | 13.5 | 38 |

Data sheet

| Size | H25 | H26 | H27 | H28 | H29 | H33 | H34 |
|------|-----|------|------|------|-----|-------|-----|
| 16 | 6.9 | – | 10.9 | – | – | 71.6 | – |
| 20 | 6.9 | – | 10.9 | – | – | 75.6 | – |
| 25 | 7.5 | 16.7 | 12.2 | 21.4 | – | 109.7 | – |
| 32 | 7.5 | 16.7 | 12.2 | 21.4 | – | 121.5 | – |
| 35 | 7.5 | 16.7 | 12.2 | 21.4 | – | 133 | – |
| 40 | 7 | 16.5 | 13.3 | 24 | 32 | 127 | 6 |
| 50 | 7 | 16.5 | 13.3 | 24 | 32 | 140 | 6 |
| 63 | 7 | 16.5 | 13.3 | 24 | 32 | 167 | 6 |

| Size | L7 ±0.02 | L22 | L23 | L24 | T5 +0.1 | T10 |
|------|-------------|-----|-----|-----|------------|------|
| 16 | 64 | 4 | 4 | 8 | 2.1 | 8.6 |
| 20 | 70 | 4 | 4 | 8 | 2.1 | 8.6 |
| 25 | 80 | 5 | 5 | – | 2.1 | 9.6 |
| 32 | 100 | 5 | 5 | – | 3.1 | 11.1 |
| 35 | 120 | 5 | 5 | – | 3.1 | 11.1 |
| 40 | 120 | 11 | 21 | 20 | 3.1 | 10.1 |
| 50 | 160 | 11 | 21 | 20 | 3.1 | 14.6 |
| 63 | 170 | 11 | 21 | 20 | 3.5 | 17.1 |

Data sheet

Dimensions – Variants

Download CAD data → www.festo.com

P...E... – Energy through-feed, pneumatic/electrical

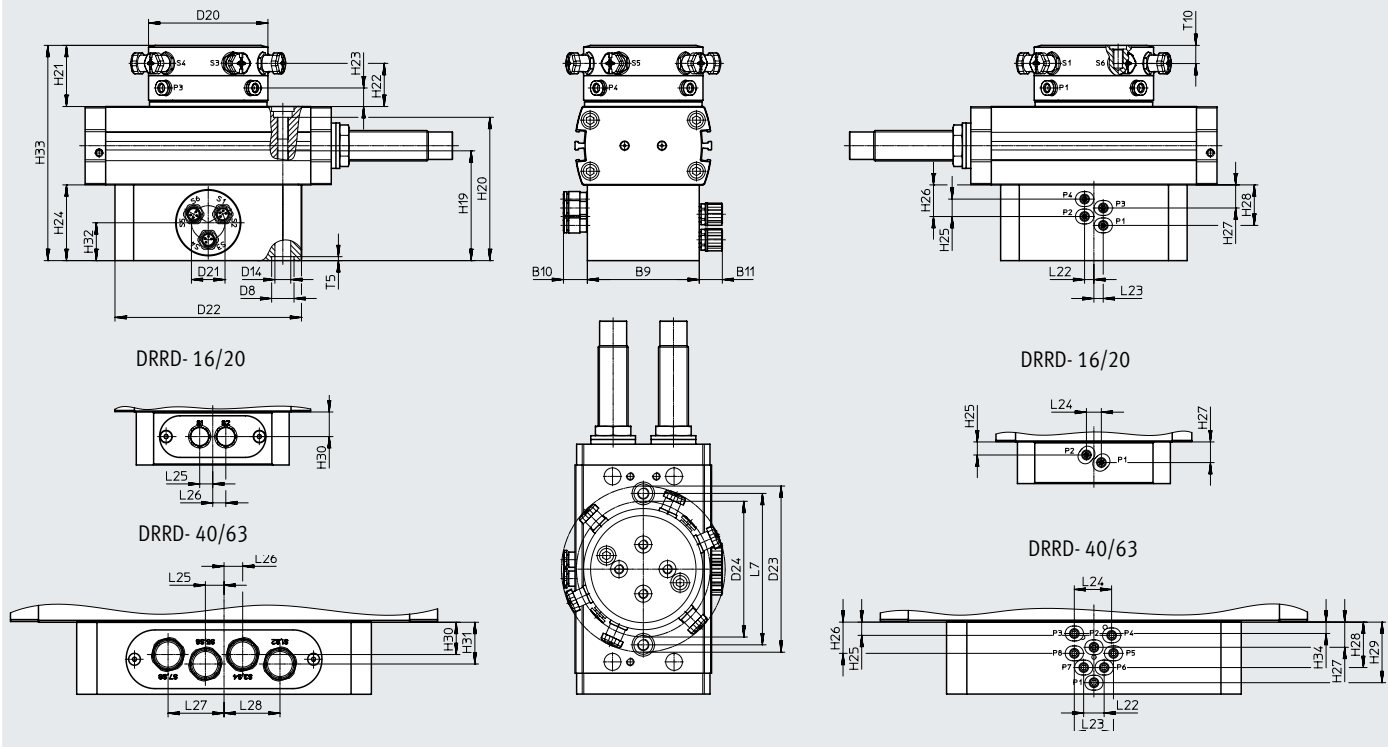

| Size | B9 | B10 | B11 | D8 ø H7 | D14 ø | D20 ø | D21 ø | D22 ø |
|------|----|------|------|---------------|----------|----------|----------|----------|
| 16 | 52 | 13.4 | 8.5 | 9 | 6 | 54 | 16 | 82 |
| 20 | 58 | 13.4 | 8.5 | 9 | 6 | 54 | 16 | 82 |
| 25 | 60 | 12.8 | 12.4 | 12 | 6.5 | 64 | 18 | 100 |
| 32 | 70 | 12.8 | 12.4 | 15 | 8.5 | 64 | 18 | 120 |
| 35 | 80 | 12.8 | 12.4 | 15 | 8.5 | 64 | 18 | 138 |
| 40 | 80 | 13.4 | 24 | 15 | 11 | 89 | – | 158 |
| 50 | 80 | 13.4 | 24 | 15 | 11 | 89 | – | 190 |
| 63 | 80 | 13.4 | 24 | 25 | 13 | 89 | – | 210 |

| Size | D23 ø | D24 ø | H21 | H22 | H23 | H24 | H25 | H26 |
|------|----------|----------|------|------|------|-----|-----|------|
| 16 | 71.1 | 70 | 28.6 | 21.1 | 7.6 | 28 | 6.9 | – |
| 20 | 71.1 | 70 | 29.6 | 22.1 | 8.6 | 28 | 6.9 | – |
| 25 | 89.8 | 71.6 | 32.3 | 22.8 | 9.8 | 40 | 7.5 | 16.7 |
| 32 | 89.8 | 71.6 | 34.5 | 25 | 12 | 40 | 7.5 | 16.7 |
| 35 | 89.8 | 71.6 | 33 | 23.5 | 10.5 | 40 | 7.5 | 16.7 |
| 40 | 138.5 | 96.9 | 40 | 28.5 | 10.5 | 38 | 7 | 16.5 |
| 50 | 138.5 | 96.9 | 44 | 32.5 | 11.5 | 38 | 7 | 16.5 |
| 63 | 138.5 | 96.9 | 48 | 36.5 | 13.5 | 38 | 7 | 16.5 |

Data sheet

| Size | H27 | H28 | H29 | H30 | H31 | H32 | H33 | H34 | L7 ±0.02 |
|------|------|------|-----|------|-----|-----|-------|-----|-------------|
| 16 | 10.9 | – | – | 15.5 | – | – | 89.6 | – | 64 |
| 20 | 10.9 | – | – | 15.5 | – | – | 93.6 | – | 70 |
| 25 | 12.2 | 21.4 | – | – | – | 20 | 113.7 | – | 80 |
| 32 | 12.2 | 21.4 | – | – | – | 20 | 124.5 | – | 100 |
| 35 | 12.2 | 21.4 | – | – | – | 20 | 136 | – | 120 |
| 40 | 13.3 | 24 | 32 | 17 | 22 | – | 146 | 6 | 120 |
| 50 | 13.3 | 24 | 32 | 17 | 22 | – | 160 | 6 | 160 |
| 63 | 13.3 | 24 | 32 | 17 | 22 | – | 186 | 6 | 170 |

| Size | L22 | L23 | L24 | L25 | L26 | L27 | L28 | T5 +0.1 | T10 |
|------|-----|-----|-----|-----|-----|-----|-----|------------|------|
| 16 | 4 | 4 | 8 | 7 | 7 | – | – | 2.1 | 8.6 |
| 20 | 4 | 4 | 8 | 7 | 7 | – | – | 2.1 | 8.6 |
| 25 | 5 | 5 | – | – | – | – | – | 2.1 | 9.6 |
| 32 | 5 | 5 | – | – | – | – | – | 3.1 | 11.1 |
| 35 | 5 | 5 | – | – | – | – | – | 3.1 | 11.1 |
| 40 | 11 | 21 | 20 | 10 | 10 | 30 | 30 | 3.1 | 10.1 |
| 50 | 11 | 21 | 20 | 10 | 10 | 30 | 30 | 3.1 | 14.6 |
| 63 | 11 | 21 | 20 | 10 | 10 | 30 | 30 | 3.5 | 17.1 |

Data sheet

Dimensions – Variants

Download CAD data → www.festo.com

Y12 – With external shock absorber

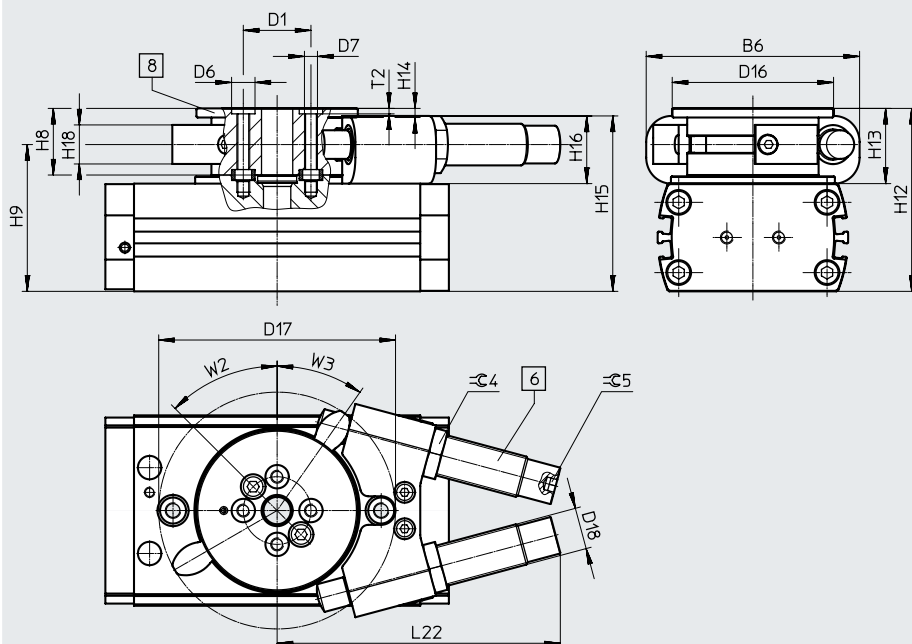

- [6] Shock absorber
- [8] Flange module

| Size | B6 ±0.2 | D1 ∅ ±0.025 | D6 ∅ H7 | D7 | D16 ∅ | D17 | D18 | H8 ±0.1 | H9 | H12 |
|------|------------|-------------------|---------------|-----|----------|-------|---------|------------|-------|------|
| 16 | 58 | 21 | 7 | M4 | 49 | 69.4 | M10x1 | 17 | 43.1 | 52.6 |
| 20 | 75 | 24 | 7 | M4 | 62 | 91 | M12x1 | 25.6 | 51.2 | 65.2 |
| 25 | 82 | 26 | 9 | M5 | 62 | 91 | M16x1 | 25.6 | 56.5 | 70.3 |
| 32 | 120 | 40 | 9 | M6 | 79 | 126.2 | M22x1.5 | 31.5 | 68.5 | 87 |
| 35 | 133 | 45 | 9 | M6 | 89 | 146.7 | M22x1.5 | 34 | 83 | 101 |
| 40 | 133 | 45 | 9 | M6 | 89 | 146.7 | M22x1.5 | 34 | 88 | 106 |
| 50 | 152 | 54 | 15 | M8 | 110 | 165.2 | M26x1.5 | 42 | 101.5 | 125 |
| 63 | 186 | 63 | 15 | M10 | 130 | 212.2 | M30x1.5 | 52 | 129.5 | 159 |

| Size | H13 | H14 | H15 | H16 | H18 | L22 max. | T2 +0.1 | W2 | W3 | ∠4 | ∠5 |
|------|------|-----|-------|------|-----|-------------|------------|-----|-----|----|----|
| 16 | 19.6 | 3.5 | 51 | 18 | 10 | 65.2 | 1.6 | 45° | 36° | 13 | 3 |
| 20 | 29.2 | 3.5 | 59.5 | 23.5 | 15 | 85.3 | 1.6 | 45° | 38° | 15 | 4 |
| 25 | 28.9 | 3.5 | 67.4 | 26 | 15 | 108.9 | 2.1 | 45° | 35° | 19 | 5 |
| 32 | 37 | 4 | 85 | 35 | 22 | 149.7 | 2.1 | 45° | 35° | 27 | 5 |
| 35 | 38 | 5 | 99 | 36 | 21 | 155.5 | 2.1 | 45° | 38° | 27 | 5 |
| 40 | 38 | 5 | 104 | 36 | 21 | 155.5 | 2.1 | 45° | 38° | 27 | 5 |
| 50 | 47 | 6 | 123 | 45 | 30 | 171.6 | 2.6 | 45° | 33° | 32 | 6 |
| 63 | 59 | 6 | 155.5 | 55.5 | 36 | 228 | 3.1 | 45° | 36° | 36 | 8 |

Data sheet

Dimensions – Variants

Download CAD data → www.festo.com

PS1 – Intermediate position

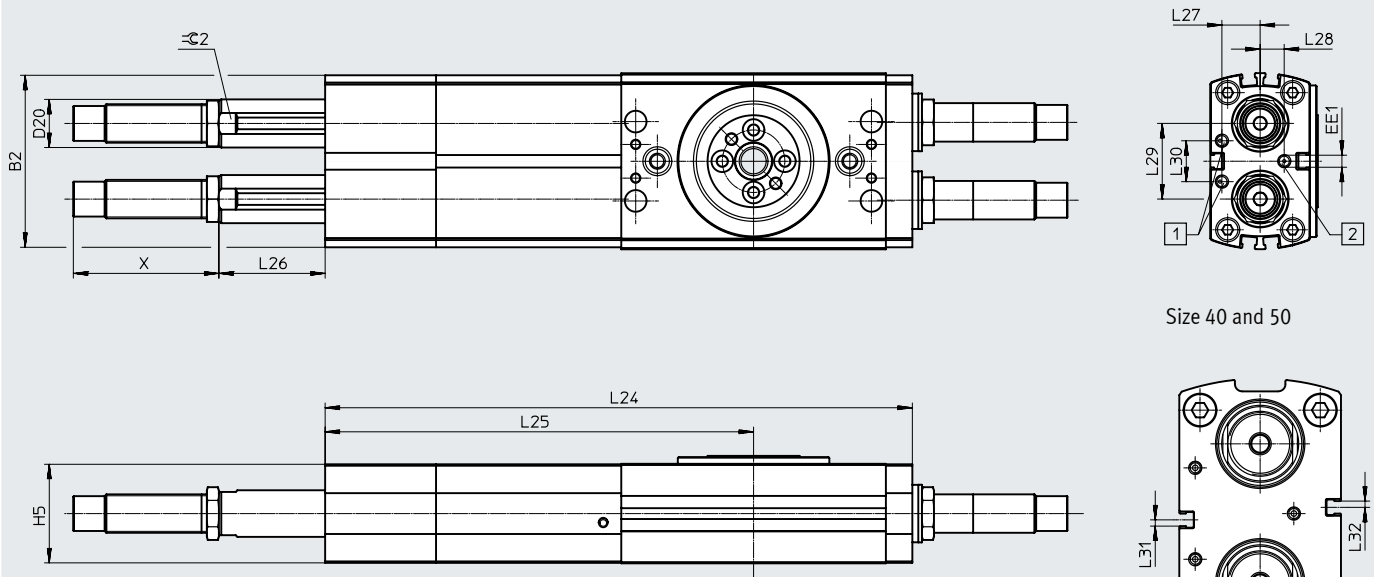

Size 40 and 50



Dimensions for X → page 41

- [1] Supply ports to rotate basic drive
- [2] Supply port to rotate into intermediate position

| Size | B2 | H5 | L24 | L25 | L26 | | L27 |
|------|-------|------|-------|-------|------|------|------|
| | | | | | min. | max. | |
| 16 | 56.2 | 32.6 | 193.1 | 140.6 | 0.3 | 21.5 | 12 |
| 20 | 63.4 | 35.6 | 205.1 | 151.1 | 4.5 | 28.4 | 14 |
| 25 | 71.5 | 41 | 244.1 | 178.1 | 14.1 | 44.2 | 15.9 |
| 32 | 92.6 | 49.6 | 320.1 | 238.6 | 3.4 | 43.5 | 19.5 |
| 35 | 104 | 62.2 | 343.1 | 254.1 | 14.8 | 54.5 | 25 |
| 40 | 111 | 67.2 | 392.1 | 277.6 | 9 | 54.1 | 27 |
| 50 | 129.9 | 77.2 | 542.6 | 391.6 | 12.3 | 86 | 30 |

| Size | L28 | L29 | L30 | L31 | L32 | D20 ∅ | EE1 | ⊕ 2 |
|------|-----|-------|-----|-----|-----|----------|------|-----|
| 16 | 6.2 | 21.65 | 15 | – | – | 14 | M5 | 12 |
| 20 | 9 | 26.25 | 16 | – | – | 16 | M5 | 14 |
| 25 | 10 | 31.45 | 17 | – | – | 20 | M5 | 18 |
| 32 | 14 | 38.45 | 16 | – | – | 28 | M5 | 24 |
| 35 | 18 | 49.6 | 18 | – | – | 32 | M5 | 27 |
| 40 | 14 | 58 | 38 | 2.6 | 2.6 | 32 | M5 | 27 |
| 50 | 20 | 78 | 44 | 5 | 5 | 36 | G1/8 | 32 |

Data sheet

| Ordering data | | | | |
|---|------|---------------------|-----------|--------------------|
| DRRD | Size | Swivel angle [°] | Part no. | Type |
| P – Elastic cushioning rings/plates at both ends | | | | |
|  | 16 | 180 | ★ 1577238 | DRRD-16-180-FH-PA |
| | 20 | | ★ 1395606 | DRRD-20-180-FH-PA |
| | 25 | | ★ 1359980 | DRRD-25-180-FH-PA |
| | 32 | | ★ 1578512 | DRRD-32-180-FH-PA |
| | 35 | | ★ 1526825 | DRRD-35-180-FH-PA |
| | 40 | | ★ 1503269 | DRRD-40-180-FH-PA |
| Y9 – Linear shock absorber, self-adjusting at both ends | | | | |
|  | 16 | 180 | ★ 1644389 | DRRD-16-180-FH-Y9A |
| | 20 | | ★ 1427379 | DRRD-20-180-FH-Y9A |
| | 25 | | ★ 1360248 | DRRD-25-180-FH-Y9A |
| | 32 | | ★ 1578518 | DRRD-32-180-FH-Y9A |
| | 35 | | ★ 1547102 | DRRD-35-180-FH-Y9A |
| | 40 | | ★ 1526986 | DRRD-40-180-FH-Y9A |

Festo core product range



Generally ready for dispatch from the factory within 24 hours

Generally ready for dispatch from the factory within 5 days

Ordering data – Modular product system

| Ordering table | | | | | | | | | | | | |
|---------------------------|--|---------------|--|---------------|---------------|---------------|--|---------------|------------|---------|------------|------|
| Size | 16 | 20 | 25 | 32 | 35 | 40 | 50 | 63 | Conditions | Code | Enter code | |
| Module no. | 574399 | 574400 | 574401 | 574402 | 574403 | 574404 | 574405 | 574407 | | | | |
| Function | Semi-rotary drive | | | | | | | | | DRRD | DRRD | |
| Size | 16 | 20 | 25 | 32 | 35 | 40 | 50 | 63 | | -... | | |
| Nominal swivel angle | 180° | | | | | | | | | -180 | -180 | |
| Output shaft | Flange shaft, hollow | | | | | | | | | -FH | -FH | |
| Energy through-feed | None | | | | | | | | | - | | |
| | Pneumatic, 2 ducts | | - | | | | | | | P2 | | |
| | Pneumatic, 2 ducts; electric, 2 signals | | - | | | | | | | P2E2 | | |
| | - | | Pneumatic, 4 ducts | | | - | | | | P4 | | |
| | - | | Pneumatic, 4 ducts; electric, 6 signals | | | - | | | | P4E6 | | |
| | - | | Pneumatic, 8 ducts | | | - | | | | P8 | | |
| | - | | Pneumatic, 8 ducts; electric, 8 signals | | | - | | | | P8E8 | | |
| Cushioning | Elastic cushioning rings/plates at both ends | | | | | | | | | - | -P | |
| | Linear shock absorber, self-adjusting at both ends | | | | | | | | | | -Y9 | |
| | - | | Linear shock absorber, self-adjusting at both ends, hard | | - | | Linear shock absorber, self-adjusting at both ends, hard | | | | -Y10 | |
| | Linear shock absorber, self-adjusting at both ends, external | | | | | | | | | [1] [5] | -Y12 | |
| | Linear shock absorber, self-adjusting at both ends, soft | | | | | | | | | - | -Y14 | |
| Position sensing | Via proximity switch | | | | | | | | | | A | A |
| EU certification | None | | | | | | | | | | | |
| | II 2GD | | | | | | | | | [2] | -EX4 | |
| Intermediate position | None | | | | | | | | | - | | |
| | 1 intermediate position | | | | | | | | | - | [3] | -PS1 |
| End-position locking | None | | | | | | | | | | | |
| | At both ends | | | | | | | | | [4] [5] | -E1 | |
| Sensor mounting, external | None | | | | | | | | | | | |
| | Mounting rail for proximity switch | | | | | | | | | [5] | -R | |
| Version | Standard | | | | | | | | | | | |
| | Splash-proof design | | | | | | | | | | -SG | |
| Operating instructions | With operating instructions | | | | | | | | | | | |
| | Without operating instructions | | | | | | | | | | -DN | |

- [1] **Y12** Not with end-position locking E1 and splash-proof design SG
 [2] **EX4** Not with end-position locking E1, energy through-feed P2E2, P4E6, P8E8 and intermediate position PS1
 [3] **PS1** Not with cushioning Y10, Y14 and with cushioning P only for size 16 ... 32
 [4] **E1** Not with sensor mounting R and splash-proof design SG
 [5] **Y12, E1, R** Not with energy through-feed P2, P2E2, P4, P4E6, P8, P8E8

Accessories

Drive shaft DARF-Q11

For size 12 ... 40

Material:

Tempered steel

RoHS-compliant

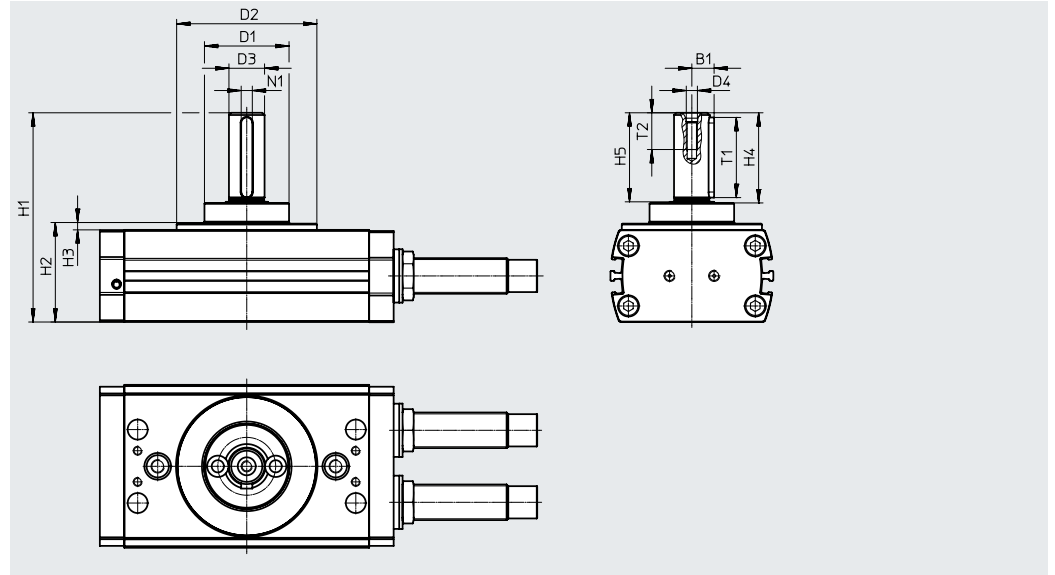

Dimensions and ordering data

| For size | B1 +0.1/-0.2 | D1 ∅ -0.2 | D2 ∅ | D3 ∅ g7 | D4 | H1 | H2 | H3 |
|----------|-----------------|-----------------|------------------|---------------|----|----------------|---------------|---------------|
| 12 | 4.8 | 30 | 30 | 8 | M3 | 56.75±0.3 | 30.75±0.2 | 0.75+0.2/-0.6 |
| 16 | 6.2 | 32 | 50 _{h7} | 10 | M3 | 66.1+0.3/-0.2 | 35.6+0.2/-0.1 | 2.6+0.3/-0.2 |
| 20 | 7.5 | 35 | 56 _{h7} | 12 | M4 | 76.8+0.3/-0.2 | 39.6+0.2/-0.1 | 3.6+0.3/-0.2 |
| 25 | 10 | 38 | 63 _{h7} | 16 | M5 | 94+0.3/-0.2 | 44.7+0.2/-0.1 | 3.3+0.3/-0.2 |
| 32 | 12.5 | 55 | 81 _{h7} | 20 | M6 | 114.8+0.3/-0.2 | 55.5+0.2/-0.1 | 5.5+0.3/-0.2 |
| 35 | 13.5 | 60 | 91 _{h7} | 22 | M8 | 126.2+0.3/-0.2 | 67+0.2/-0.1 | 4+0.3/-0.2 |
| 40 | 13.5 | 60 | 91 _{h7} | 22 | M8 | 131.2+0.3/-0.2 | 72+0.2/-0.1 | 4+0.3/-0.2 |

| For size | H4 | H5 | T1 | T2 +2 | N1 ²⁾ P9 | Weight [g] | Part no. | Type ¹⁾ |
|----------|------|--------|----------------------|----------|------------------------|---------------|----------|--------------------|
| 12 | 20.5 | 20±0.1 | 16 ^{+0.2} | 11.6 | 2 | 38 | 4835942 | DARF-Q11-12 |
| 16 | 23.5 | 23±0.1 | 18.1 ^{+0.3} | 11.6 | 3 | 60 | 4835943 | DARF-Q11-16 |
| 20 | 30.5 | 30±0.1 | 25.1 ^{+0.3} | 13.5 | 4 | 79 | 4835941 | DARF-Q11-20 |
| 25 | 40.5 | 40±0.2 | 36.1 ^{+0.3} | 16.5 | 5 | 145 | 4835938 | DARF-Q11-25 |
| 32 | 50.5 | 50±0.2 | 45.1 ^{+0.3} | 21 | 6 | 287 | 4835940 | DARF-Q11-32 |
| 35 | 50.5 | 50±0.2 | 45.1 ^{+0.3} | 32 | 6 | 350 | 4835939 | DARF-Q11-35/40 |
| 40 | 50.5 | 50±0.2 | 45.1 ^{+0.3} | 32 | 6 | 350 | 4835939 | DARF-Q11-35/40 |

1) Suitable for ATEX

2) Feather key to DIN 6885

Accessories

Clamping unit DADL-EL

For size 16 ... 63

(Order code: E1)

Products in stock

Material:

Housing: anodised aluminium

Bearing: plastic

RoHS-compliant

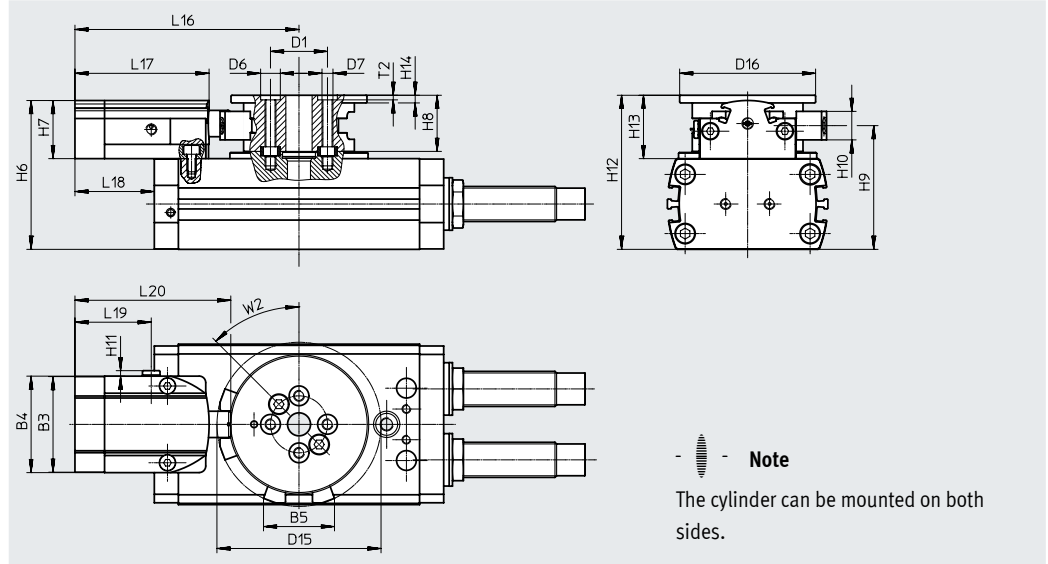

Dimensions and ordering data

| For size | B3 | B4 | B5 | D1 ∅ | D6 ∅ | D7 | D15 ∅ | D16 ∅ | H6 | H7 | H8 | H9 |
|----------|------|------|------|---------|---------|-----|----------|----------|------|-------|------|-------|
| | ±0.2 | ±0.2 | | ±0.025 | H7 | | | | | ±0.15 | ±0.1 | |
| 16 | 37.6 | 38 | 26.9 | 21 | 7 | M4 | 61.9 | 49 | 51 | 18 | 17 | 43.1 |
| 20 | 43.6 | 44 | 32.4 | 24 | 7 | M4 | 74.9 | 62 | 62.5 | 26.5 | 25.6 | 51.2 |
| 25 | 43.6 | 44 | 32.4 | 26 | 9 | M5 | 74.9 | 62 | 67.9 | 26.5 | 25.6 | 56.5 |
| 32 | 43.6 | 44 | 39.4 | 40 | 9 | M6 | 95.4 | 79 | 79 | 26.7 | 31.5 | 68.5 |
| 35 | 57.6 | 58 | 50.2 | 45 | 9 | M6 | 110.9 | 89 | 98 | 35 | 34 | 83 |
| 40 | 57.6 | 58 | 50.2 | 45 | 9 | M6 | 110.9 | 89 | 103 | 35 | 34 | 88 |
| 50 | 71.4 | 72 | 59.6 | 54 | 15 | M8 | 124.3 | 110 | 123 | 45 | 42 | 101.5 |
| 63 | 71.4 | 72 | 65.8 | 63 | 15 | M10 | 148.5 | 130 | 149 | 49 | 52 | 129.5 |

| For size | H10 | H11 | H12 | H13 | H14 | L16 | L17 | L18 | L19 | L20 | T2 | W2 |
|----------|------|-----|------|------|-----|-------|------|-------|------|------|------|-----|
| | | | | | | | | | | | +0.1 | |
| 16 | 9 | 2.5 | 52.6 | 19.6 | 3.5 | 83 | 50 | 30.5 | 34 | 58.3 | 1.6 | 45° |
| 20 | 13 | 2.5 | 65.2 | 29.2 | 3.5 | 102.2 | 61.2 | 48.2 | 34.8 | 71.1 | 1.6 | 45° |
| 25 | 13 | 2.5 | 70.3 | 28.9 | 3.5 | 102.2 | 61.2 | 36.2 | 34.8 | 71.1 | 2.1 | 45° |
| 32 | 17 | 2.5 | 87 | 37 | 4 | 112.2 | 61.2 | 30.7 | 34.8 | 71.1 | 2.1 | 45° |
| 35 | 14.8 | 2.5 | 101 | 38 | 5 | 132.5 | 70.6 | 43.5 | 42.6 | 85.4 | 2.1 | 45° |
| 40 | 14.8 | 2.5 | 106 | 38 | 5 | 132.5 | 70.6 | 18 | 42.6 | 85.4 | 2.1 | 45° |
| 50 | 19 | 4.6 | 125 | 47 | 6 | 151 | 81 | 0 | 46 | 98 | 2.6 | 45° |
| 63 | 22 | 4.6 | 159 | 59 | 6 | 163 | 81 | -29.5 | 46 | 99.5 | 3.1 | 45° |

| For size | Pneumatic connection | Operating pressure [bar] | Position sensing | Adjustable swivel angle [°] | Weight [g] | Part no. | Type |
|----------|----------------------|-----------------------------|----------------------|--------------------------------|---------------|-------------------|----------------|
| 16 | M5 | 3 ... 8 | Via proximity switch | 60 ... 200 | 166 | 1692770 | DADL-EL-Q11-16 |
| 20 | | | | | 382 | 1579786 | DADL-EL-Q11-20 |
| 25 | | 370 | | | 1568183 | DADL-EL-Q11-25 | |
| 32 | | 600 | | | 55 ... 200 | 1631139 | DADL-EL-Q11-32 |
| 35 | | | | | 57 ... 200 | 900 | 1544900 |
| 40 | G1/8 | 3 ... 8 | 57 ... 200 | 900 | 1544900 | DADL-EL-Q11-35/40 | |
| 50 | | | | 62 ... 200 | 1610 | 1796637 | DADL-EL-Q11-50 |
| 63 | | | | 55 ... 200 | 2380 | 1941568 | DADL-EL-Q11-63 |

Accessories

Sensing kit DASI-...-KT

For size 16 ... 63

(order code: R)

Products in stock

Material:
Anodised aluminium
RoHS-compliant

For sensing the piston position using
inductive proximity switches SIES

→ page 61

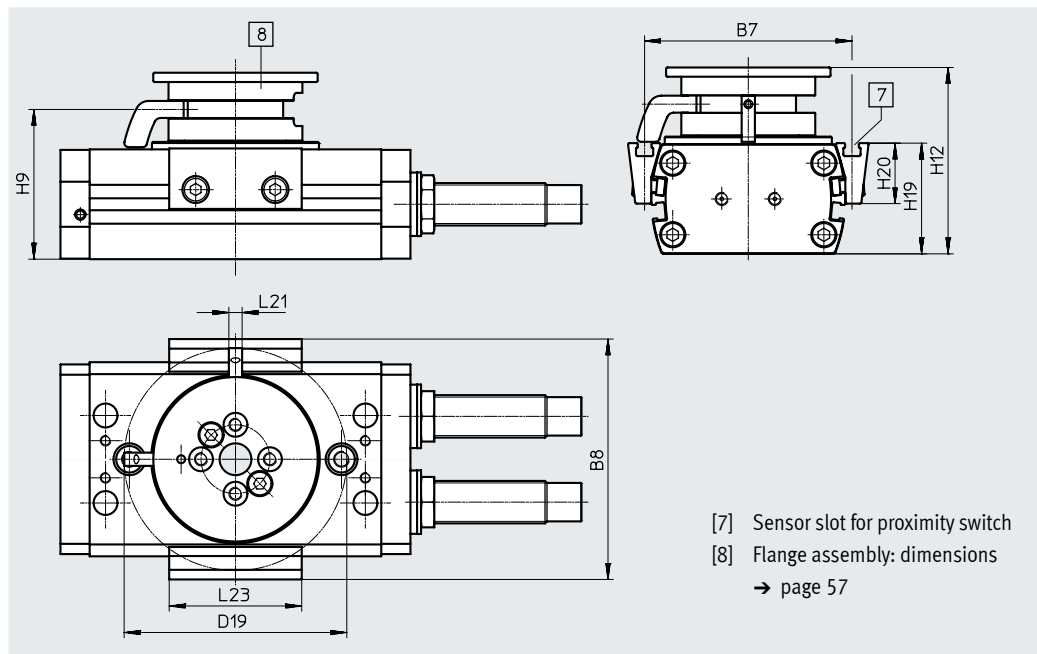

[7] Sensor slot for proximity switch
[8] Flange assembly: dimensions
→ page 57





Dimensions and ordering data

| For size | B7 | B8 | D19 ∅ | H9 | H12 | H19 |
|----------|------|-------|----------|-------|------|------|
| 16 | 64.4 | 76.1 | 70.9 | 43.1 | 52.6 | 33.5 |
| 20 | 74 | 85.7 | 84 | 51.2 | 65.2 | 36.4 |
| 25 | 78.2 | 90.7 | 84 | 56.5 | 70.3 | 41.8 |
| 32 | 100 | 113.5 | 107.5 | 68.5 | 87 | 50.5 |
| 35 | 116 | 132.9 | 125.2 | 83 | 101 | 63.5 |
| 40 | 118 | 135.8 | 125.2 | 88 | 106 | 68.5 |
| 50 | 136 | 155.3 | 146.6 | 101.5 | 125 | 79.1 |
| 63 | 163 | 185.3 | 173.9 | 129.5 | 159 | 101 |

| For size | H20 ±0.1 | L21 | L23 | Weight [g] | Part no. | Type ¹⁾ |
|----------|-------------|-----|-----|---------------|----------|--------------------|
| 16 | 18.5 | 5 | 50 | 110 | 1693008 | DASI-Q11-16-A-KT |
| 20 | 20.2 | 5 | 50 | 192 | 1580899 | DASI-Q11-20-A-KT |
| 25 | 22.8 | 5 | 50 | 192 | 1568461 | DASI-Q11-25-A-KT |
| 32 | 26.5 | 7 | 50 | 366 | 1632097 | DASI-Q11-32-A-KT |
| 35 | 33.1 | 7 | 50 | 485 | 1551144 | DASI-Q11-35-A-KT |
| 40 | 35.5 | 7 | 50 | 485 | 1550027 | DASI-Q11-40-A-KT |
| 50 | 43 | 7 | 50 | 810 | 1797135 | DASI-Q11-50-A-KT |
| 63 | 55 | 7 | 50 | 1390 | 1946877 | DASI-Q11-63-A-KT |

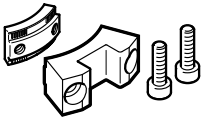
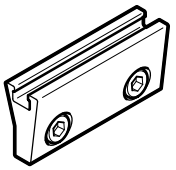
1) Suitable for ATEX

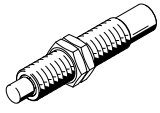
Accessories

| Ordering data ²⁾ | | For size | Description | Weight [g] | Part no. | Type | PE ¹⁾ |
|---|--|---|-------------|----------------|----------------------------|------|------------------|
| Clamping component DADL-EC | | | | | | | |
|  | 16 | For securing an intermediate position in combination with the clamping unit DADL-EL | 18 | 1692496 | DADL-EC-Q11-16 | | 1 |
| | 20, 25 | | 36 | 1435411 | DADL-EC-Q11-20/25 | | |
| | 32 | | 67 | 1631170 | DADL-EC-Q11-32 | | |
| | 35, 40 | | 98 | 1535091 | DADL-EC-Q11-35/40 | | |
| | 50 | | 140 | 1796626 | DADL-EC-Q11-50 | | |
| | 63 | | 220 | 1941355 | DADL-EC-Q11-63 | | |
| | Sensor bracket DASI-...-SR³⁾ | | | | | | |
|  | 16 | Additional sensing option in combination with the sensing kit DASI-...-KT | 28 | 1692983 | DASI-Q11-16-A-SR | | 2 |
| | 20 | | 32 | 1581420 | DASI-Q11-20-A-SR | | |
| | 25 | | 32 | 1568451 | DASI-Q11-25-A-SR | | |
| | 32 | | 42 | 1631997 | DASI-Q11-32-A-SR | | |
| | 35 | | 62 | 1550870 | DASI-Q11-35-A-SR | | |
| | 40 | | 62 | 1548054 | DASI-Q11-40-A-SR | | |
| | 50 | | 75 | 1797071 | DASI-Q11-50-A-SR | | |
| | 63 | | 110 | 1971563 | DASI-Q11-63-A-SR | | |
| Switch lug DASI-...-SL³⁾ | | | | | | | |
|  | 16 | Additional sensing option in combination with the sensing kit DASI-...-KT | 2.5 | 1692969 | DASI-Q11-16-A-SL | | 1 |
| | 20, 25 | | 4 | 1568436 | DASI-Q11-20/25-A-SL | | |
| | 32 | | 6 | 1631824 | DASI-Q11-32-A-SL | | |
| | 35, 40 | | 8 | 1548155 | DASI-Q11-35/40-A-SL | | |
| | 50 | | 10 | 1797021 | DASI-Q11-50-A-SL | | |
| | 63 | | 15 | 1971550 | DASI-Q11-63-A-SL | | |
| | Shock absorber DYSC³⁾ | | | | | | |
|  | 12 | <ul style="list-style-type: none"> Self-adjusting shock absorbers for use as external cushioning (Y12) Included in the scope of delivery for semi-rotary drive DRRD-...-Y12 | 9 | 548011 | DYSC-5-5-Y1F | | 1 |
| | 16 | | 17 | 548012 | DYSC-7-5-Y1F | | |
| | 20 | | 36 | 548013 | DYSC-8-8-Y1F | | |
| | 25 | | 81 | 548014 | DYSC-12-12-Y1F | | |
| | 32, 35, 40 | | 210 | 553593 | DYSC-16-18-Y1F | | |
| | 50 | | 370 | 2479149 | DYSC-20-18-Y1F | | |
| | 63 | | 575 | 2480234 | DYSC-25-25-Y1F | | |
| Centring sleeve ZBH³⁾ | | | | | | | |
|  | 8, 10 | <ul style="list-style-type: none"> For centring the semi-rotary drive 2 included in the scope of delivery for the semi-rotary drive | 1 | 186717 | ZBH-7 | | 10 |
| | 12, 16, 20 | | 1 | 8137184 | ZBH-9-B | | |
| | 25 | | 1 | 8137185 | ZBH-12-B | | |
| | 32 ... 50 | | 3 | 191409 | ZBH-15 | | |
| | 63 | | 5 | 8023856 | ZBH-25 | | |
| | 8, 10, 12 | <ul style="list-style-type: none"> For centring attachments on the flange shaft Centring sleeves are included in the scope of delivery of the attachments | 1 | 189652 | ZBH-5 | | |
| | 16, 20 | | 1 | 186717 | ZBH-7 | | |
| | 25 ... 40 | | 1 | 8137184 | ZBH-9-B | | |
| | 50 | | 1 | 8137185 | ZBH-12-B | | |
| | 63 | | 3 | 191409 | ZBH-15 | | |



- 1) Packaging unit
2) Products in stock
3) Suitable for ATEX

Accessories

Proximity switch for size 8 ... 12

Ordering data – Proximity switch for C-slot, magneto-resistive

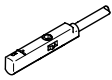
Data sheets → Internet: smt

| | Type of mounting | Switching output | Electrical connection, outlet direction of connection | Cable length [m] | Part no. | Type |
|--|---------------------------------|------------------|---|------------------|----------|----------------------------|
| N/O contact | | | | | | |
|  | Inserted in the slot from above | PNP | Cable, 3-wire, in-line | 2.5 | ★ 551373 | SMT-10M-PS-24V-E-2,5-L-OE |
| | | | Plug M8x1, 3-pin, in-line | 0.3 | ★ 551375 | SMT-10M-PS-24V-E-0,3-L-M8D |
| | | | Plug M8x1, 3-pin, crosswise | 0.3 | 551376 | SMT-10M-PS-24V-E-0,3-Q-M8D |
|  | Inserted in the slot lengthwise | PNP | Cable, 3-wire, crosswise | 2.5 | 547862 | SMT-10G-PS-24V-E-2,5Q-OE |
| | | | Plug M8x1, 3-pin, crosswise | 0.3 | 547863 | SMT-10G-PS-24V-E-0,3Q-M8D |
| | | | | | | |

Ordering data – Proximity switches for C-slot, magnetic reed

Data sheets → Internet: sme

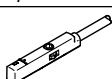
| | Type of mounting | Switching output | Electrical connection, outlet direction of connection | Cable length [m] | Part no. | Type |
|--|---------------------------------|------------------|---|------------------|----------|----------------------------|
| N/O contact | | | | | | |
|  | Inserted in the slot from above | Contacting | Plug M8x1, 3-pin, in-line | 0.3 | ★ 551367 | SME-10M-DS-24V-E-0,3-L-M8D |
| | | | Cable, 3-wire, in-line | 2.5 | ★ 551365 | SME-10M-DS-24V-E-2,5-L-OE |
| | | | Cable, 2-wire, in-line | 2.5 | ★ 551369 | SME-10M-ZS-24V-E-2,5-L-OE |

Proximity switch for size 16 ... 63

Ordering data – Proximity switches for T-slot, magneto-resistive

Data sheets → Internet: smt

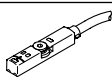

| | Type of mounting | Switching output | Electrical connection | Cable length [m] | Part no. | Type |
|--|--|------------------|-----------------------|------------------|----------|---------------------------|
| N/O contact | | | | | | |
|  | Inserted in the slot from above, flush with the cylinder profile, short design | PNP | Cable, 3-wire | 2.5 | ★ 574335 | SMT-8M-A-PS-24V-E-2,5-OE |
| | | | Plug M8x1, 3-pin | 0.3 | ★ 574334 | SMT-8M-A-PS-24V-E-0,3-M8D |
| | | | Plug M12x1, 3-pin | 0.3 | ★ 574337 | SMT-8M-A-PS-24V-E-0,3-M12 |
| | | NPN | Cable, 3-wire | 2.5 | ★ 574338 | SMT-8M-A-NS-24V-E-2,5-OE |
| | | | Plug M8x1, 3-pin | 0.3 | ★ 574339 | SMT-8M-A-NS-24V-E-0,3-M8D |

N/C contact

| | | | | | | |
|--|--|-----|---------------|-----|----------|--------------------------|
|  | Inserted in the slot from above, flush with the cylinder profile, short design | PNP | Cable, 3-wire | 7.5 | ★ 574340 | SMT-8M-A-PO-24V-E-7,5-OE |
|--|--|-----|---------------|-----|----------|--------------------------|

Ordering data – Proximity switches for T-slot, magnetic reed

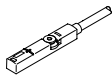
Data sheets → Internet: sme

| | Type of mounting | Switching output | Electrical connection | Cable length [m] | Part no. | Type |
|--|--|------------------|-----------------------|------------------|----------|-------------------------|
| N/O contact | | | | | | |
|  | Inserted in the slot from above, flush with the cylinder profile | Contacting | Cable, 3-wire | 2.5 | ★ 543862 | SME-8M-DS-24V-K-2,5-OE |
| | | | | 5.0 | ★ 543863 | SME-8M-DS-24V-K-5,0-OE |
| | | | Cable, 2-wire | 2.5 | ★ 543872 | SME-8M-ZS-24V-K-2,5-OE |
| | | | Plug M8x1, 3-pin | 0.3 | ★ 543861 | SME-8M-DS-24V-K-0,3-M8D |
|  | Inserted in the slot lengthwise, flush with the cylinder profile | Contacting | Cable, 3-wire | 2.5 | 150855 | SME-8-K-LED-24 |
| | | | Plug M8x1, 3-pin | 0.3 | 150857 | SME-8-S-LED-24 |

Festo core product range



- ★ Generally ready for dispatch from the factory within 24 hours
- ☆ Generally ready for dispatch from the factory within 5 days

Accessories

Proximity switch for size 16 ... 63

Ordering data – Proximity switches for T-slot, inductive

Data sheets → Internet: sies

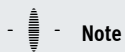

| | Type of mounting | Switching output | Electrical connection | Cable length [m] | Part no. | Type |
|---|--|------------------|-----------------------|------------------|----------|--------------------------|
| N/O contact | | | | | | |
|  | Inserted in the slot from above, flush with the cylinder profile | PNP | Cable, 3-wire | 7.5 | 551386 | SIES-8M-PS-24V-K-7,5-OE |
| | | | Plug M8x1, 3-pin | 0.3 | 551387 | SIES-8M-PS-24V-K-0,3-M8D |
| | | NPN | Cable, 3-wire | 7.5 | 551396 | SIES-8M-NS-24V-K-7,5-OE |
| | | | Plug M8x1, 3-pin | 0.3 | 551397 | SIES-8M-NS-24V-K-0,3-M8D |
| N/C contact | | | | | | |
|  | Inserted in the slot from above, flush with the cylinder profile | PNP | Cable, 3-wire | 7.5 | 551391 | SIES-8M-PO-24V-K-7,5-OE |
| | | | Plug M8x1, 3-pin | 0.3 | 551392 | SIES-8M-PO-24V-K-0,3-M8D |
| | | NPN | Cable, 3-wire | 7.5 | 551401 | SIES-8M-NO-24V-K-7,5-OE |
| | | | Plug M8x1, 3-pin | 0.3 | 551402 | SIES-8M-NO-24V-K-0,3-M8D |

**Note**

The inductive proximity switches SIES can only be used in combination with the sensing kit DASI-...-KT.

Ordering data – Connecting cables

Data sheets → Internet: nebu

| | Electrical connection, left | Electrical connection, right | Cable length [m] | Part no. | Type |
|---|------------------------------|------------------------------|------------------|----------|---------------------|
|  | Straight socket, M8x1, 3-pin | Cable, open end, 3-wire | 2.5 | ★ 541333 | NEBU-M8G3-K-2.5-LE3 |
| | | | 5 | ★ 541334 | NEBU-M8G3-K-5-LE3 |
|  | Angled socket, M8x1, 3-pin | Cable, open end, 3-wire | 2.5 | ★ 541338 | NEBU-M8W3-K-2.5-LE3 |
| | | | 5 | ★ 541341 | NEBU-M8W3-K-5-LE3 |

Festo core product range



★ Generally ready for dispatch from the factory within 24 hours

★ Generally ready for dispatch from the factory within 5 days

Accessories

Position transmitter for size 16 ... 63

The position transmitter continuously senses the position of the piston.

It has an analogue output with an output signal in proportion to the piston position.

Ordering data – Position transmitter for T-slot

Data sheets → Internet: position transmitter

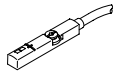
| | Type of mounting | Electrical connection | Analogue output [V] | Cable length [m] | Part no. | Type |
|--|---------------------------------|---------------------------|---------------------|------------------|---------------|----------------------------|
|  | Inserted in the slot from above | Plug M8x1, 4-pin, in-line | 0 ... 10 | 0.3 | 553744 | SMAT-8M-U-E-0,3-M8D |

| Size | 16 | 20 | 25 | 32 | 35 | 40 | 50 | 63 |
|--|-----|-----|-----|-----|-----|-----|----|----|
| Position measuring range for SMAT-8M [°] | 151 | 120 | 183 | 159 | 185 | 132 | 82 | 64 |

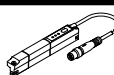
| | Position measuring range | Type of mounting | Electrical connection | Analogue output [mA] | Cable length [m] | Part no. | Type |
|--|--------------------------|---------------------------------|---------------------------|----------------------|------------------|----------------|-------------------------------------|
|  | 0 ... 50 | Inserted in the slot from above | Plug M8x1, 4-pin, in-line | 4 ... 20 | 0.3 | 1531265 | SDAT-MHS-M50-1L-SA-E-0.3-M8 |
| | 0 ... 80 | | | | | 1531266 | SDAT-MHS-M80-1L-SA-E-0.3-M8 |
| | 0 ... 100 | | | | | 1531267 | SDAT-MHS-M100-1L-SA-E-0.3-M8 |
| | 0 ... 125 | | | | | 1531268 | SDAT-MHS-M125-1L-SA-E-0.3-M8 |
| | 0 ... 160 | | | | | 1531269 | SDAT-MHS-M160-1L-SA-E-0.3-M8 |

Ordering data – Connecting cables

Data sheets → Internet: nebu

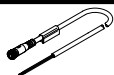
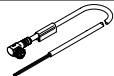
| | Electrical connection, left | Electrical connection, right | Cable length [m] | Part no. | Type |
|--|------------------------------|------------------------------|------------------|---------------|----------------------------|
|  | Straight socket, M8x1, 4-pin | Cable, open end, 4-wire | 2.5 | 541342 | NEBU-M8G4-K-2.5-LE4 |
| | | | 5 | 541343 | NEBU-M8G4-K-5-LE4 |
|  | Angled socket, M8x1, 4-pin | Cable, open end, 4-wire | 2.5 | 541344 | NEBU-M8W4-K-2.5-LE4 |
| | | | 5 | 541345 | NEBU-M8W4-K-5-LE4 |

Accessories

Wiring of the proximity switches in combination with the energy through-feed

Size 16/20

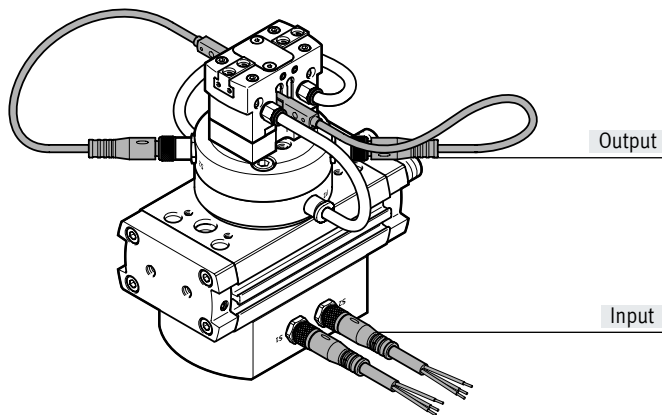

Size 25/32/35

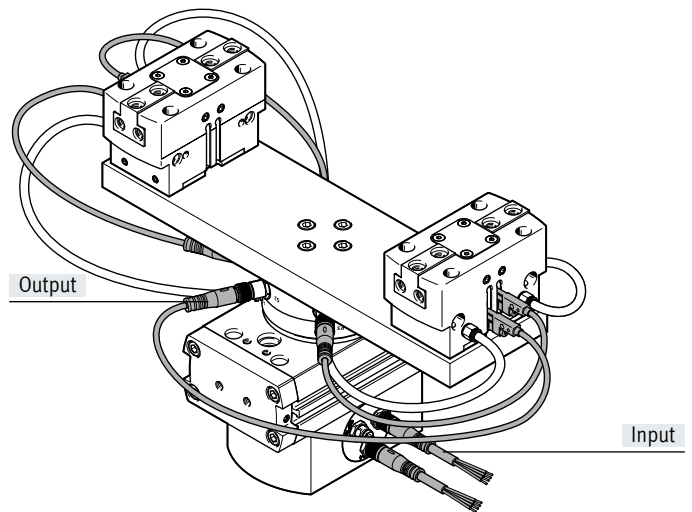

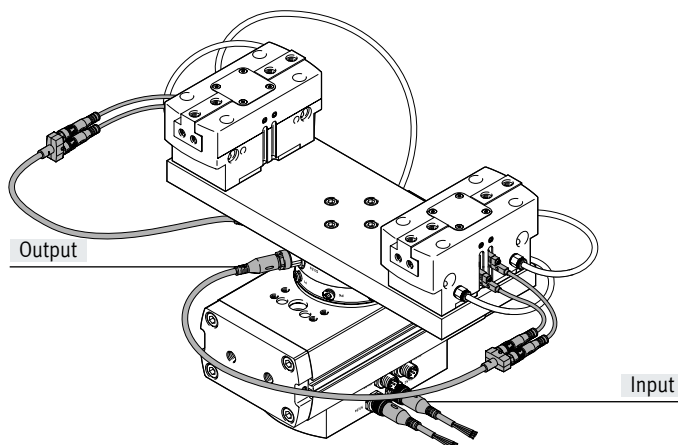

Size 40/50/63



Note

Proximity switches with plugs must be used for attachments (e.g. grippers) at the output. For sizes 16 ... 35 these can be connected directly to the energy through-feed module.

For sizes 40 ... 63, the proximity switch must be connected to the energy through-feed module through a Y-distributor.

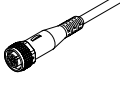
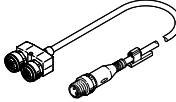
| Ordering data | | | | | | Data sheets → Internet: nebu |
|---|--|----------------------------------|-------------------|----------|--------------------------------|------------------------------|
| | Electrical connection left | Electrical connection right | Cable length [m] | Part no. | Type | |
| Input – Connecting cable | | | | | | |
| Size 16/20 | | | | | | |
|  | Straight socket, M8x1, 3-pin | Cable, open end, 3-wire | 2.5 | ★ 541333 | NEBU-M8G3-K-2.5-LE3 | |
| | Straight socket, M8x1, 3-pin | Cable, open end, 3-wire | 5 | ★ 541334 | NEBU-M8G3-K-5-LE3 | |
| Size 25/32/35 | | | | | | |
|  | Straight socket, M8x1, 4-pin | Cable, open end, 4-wire | 2.5 | 541342 | NEBU-M8G4-K-2.5-LE4 | |
| | Straight socket, M8x1, 4-pin | Cable, open end, 4-wire | 5 | 541343 | NEBU-M8G4-K-5-LE4 | |
| Size 40/50/63 | | | | | | |
|  | Straight socket, M12x1, 5-pin | Cable, open end, 4-wire | 2.5 | ★ 550326 | NEBU-M12G5-K-2.5-LE4 | |
| | Straight socket, M12x1, 5-pin | Cable, open end, 4-wire | 5 | ★ 541328 | NEBU-M12G5-K-5-LE4 | |
| Output – Y-distributor | | | | | | |
| Size 40/50/63 | | | | | | |
|  | Straight plug, M12x1, 4-pin | 2x straight sockets, M8x1, 3-pin | 0.5 ¹⁾ | 8032867 | NEDY-L2R1-V1-M8G3-U-M12G4-0.5R | |
| | 1) Cable lengths can be selected between 0.3 m and 30 m → Internet: nedy | | | | | |

Festo core product range

- ★ Generally ready for dispatch from the factory within 24 hours
- ★ Generally ready for dispatch from the factory within 5 days

Accessories

Setting the swivel speed

Basic drive and intermediate position module must only be operated with controlled air flow. The flow control should be connected as close as possible to the semi-rotary drive (e.g. one-way flow control valve GRLA-...) → table below

In the event of pressure failure, the payload may hit an end position in an uncontrolled manner. In order to prevent this, piloted check valves HGL or an air reservoir VZS are recommended.

Ordering data – Accessories for basic drive

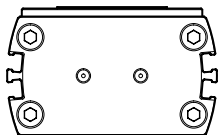

| | For size | Description | Weight [g] | Part no. | Type | PE ¹⁾ |
|--|---------------------------|---------------------------|------------|----------|-------------------|------------------|
| One-way flow control valve GRLA | | | | | | |
| | 16 ²⁾ , 20, 25 | • To set the swivel speed | 14 | ★ 197576 | GRLA-M5-QS-3-RS-D | 1 |
| | 32, 35, 40 | | 14 | ★ 197577 | GRLA-M5-QS-4-RS-D | |
| | | | 30 | 151169 | GRLA-1/8-RS-B | |
| | | | 59 | 151175 | GRLA-1/4-RS-B | |
| | 63 | | 97 | 151178 | GRLA-3/8-B | |

1) Packaging unit

Ordering data – Accessories for intermediate position (PS1)

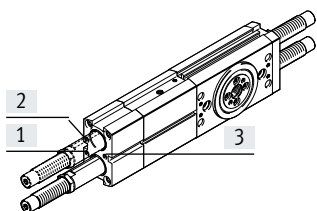

The following movements are adjusted using the supply ports [1] and [2]: end position → intermediate position

Both directions can be adjusted separately from each other.

The following movement is adjusted via supply port [3]:

Intermediate position → end position

Both directions are set simultaneously.

| | For size | Description | Weight [g] | Part no. | Type | PE ¹⁾ |
|--|---------------------------------------|---|------------|----------|-------------------|------------------|
| One-way flow control valve GRLA | | | | | | |
| | 16 ²⁾ , 20, 25, 32, 35, 40 | • To set the swivel speed from the intermediate position | 14 | ★ 197576 | GRLA-M5-QS-3-RS-D | 1 |
| | 50 | | 14 | ★ 197577 | GRLA-M5-QS-4-RS-D | |
| | | | 30 | 151169 | GRLA-1/8-RS-B | |
| Check valve HGL | | | | | | |
| | 20, 25, 32, 35, 40 | • For cushioning the payload in the event of a loss of compressed air | 21 | ★ 530029 | HGL-M5-B | 1 |
| | 50 | | 21 | ★ 530038 | HGL-M5-QS-4 | |
| | | | 26 | 543253 | HGL-1/8-1/8-B | |
| | | | 21 | ★ 530030 | HGL-1/8-B | |
| Air reservoir VZS | | | | | | |
| | 16, 20, 25, 32, 35, 40, 50 | • For cushioning the payload in the event of a loss of compressed air | 8600 | 192161 | VZS-20-B | 1 |

1) Packaging unit

2) Strongly recommended for this size

Festo core product range

- ★ Generally ready for dispatch from the factory within 24 hours
- ★ Generally ready for dispatch from the factory within 5 days

Accessories

Adapter kit DHAA

Material:
Wrought aluminium alloy
Free of copper and PTFE
RoHS-compliant

 **Note**
The kit includes the individual mounting interface as well as the necessary mounting material.

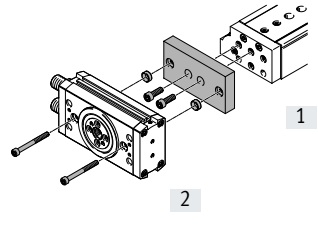
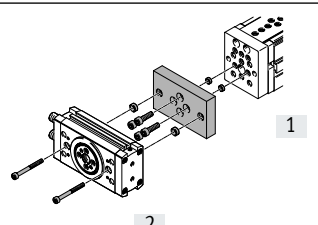
| Permissible drive/drive combinations with adapter kit | | | | | | | Download CAD data → www.festo.com |
|---|----------------|---------------------------------------|-------------------------------|----------|--------------------------|-------------------|--|
| Combination | [1] Drive Size | [2] Drive Size | Adapter kit CRC ¹⁾ | Part no. | Type | Quantity required | |
|  | DGSL | DRRD | DHAA | | | | |
| | 4 | 8 | 2 | 2767489 | DHAA-D-G6-4-Q11-8 | 1 | |
| | 6 | 8 | | 2762930 | DHAA-D-G6-6-Q11-8 | | |
| | 8, 10 | 10 | | 2737394 | DHAA-D-G6-8/10-Q11-10 | | |
| | 12, 16 | 10 | | 2737247 | DHAA-D-G6-12/16-Q11-10 | | |
| | 8, 10 | 12 | | 2736429 | DHAA-D-G6-8/10-Q11-12 | | |
| | 12 | 12 | | 2782718 | DHAA-D-G6-12-Q11-12 | | |
| | 16 | 12 | | 2734418 | DHAA-D-G6-16-Q11-12 | | |
| | 20 | 16 | | 1917841 | DHAA-D-G6-20-Q11-16 | | |
| | 20, 25 | 20 | | 1916912 | DHAA-D-G6-20/25-Q11-20 | | |
| | 25 | 25 | | 1707360 | DHAA-D-G6-25-Q11-25 | | |
| | DGSL | DRRD-...-P...E...²⁾ | DHAA | | | | |
| | 20 | 16 | 2 | 2332271 | DHAA-D-G6-20-Q11-16-E | 1 | |
| | 20, 25 | 20 | | 2332452 | DHAA-D-G6-20/25-Q11-20-E | | |
| | 25 | 25 | | 2332584 | DHAA-D-G6-25-Q11-25-E | | |
|  | EGSL | DRRD | DHAA | | | | |
| | 35 | 8 | 2 | 2730033 | DHAA-D-E8-35-Q11-8 | 1 | |
| | 35 | 10 | | 2729506 | DHAA-D-E8-35-Q11-10 | | |
| | 45 | 10 | | 2728486 | DHAA-D-E8-45-Q11-10 | | |
| | 35 | 12 | | 2719384 | DHAA-D-E8-35-Q11-12 | | |
| | 45, 55 | 12 | | 2715152 | DHAA-D-E8-45/55-Q11-12 | | |
| | 55 | 16 | | 1926914 | DHAA-D-E8-55-Q11-16 | | |
| | 75 | 16 | | 1928306 | DHAA-D-E8-75-Q11-16 | | |
| | 75 | 20 | | 1930038 | DHAA-D-E8-75-Q11-20 | | |
| | EGSL | DRRD-...-P...E...²⁾ | DHAA | | | | |
| | 55 | 16 | 2 | 2279410 | DHAA-D-E8-55-Q11-16-E | 1 | |
| | 75 | 16 | | 2279453 | DHAA-D-E8-75-Q11-16-E | | |
| | 75 | 20 | | 2279473 | DHAA-D-E8-75-Q11-20-E | | |

1) Corrosion resistance class CRC 2 to Festo standard FN 940070

Moderate corrosion stress. Indoor applications in which condensation can occur. External visible parts with primarily decorative surface requirements which are in direct contact with a normal industrial environment.

2) With energy through-feed

Accessories

Adapter kit DHAA

Material:
Wrought aluminium alloy
Free of copper and PTFE
RoHS-compliant

 **Note**
The kit includes the individual mounting interface as well as the necessary mounting material.

Permissible drive/drive combinations with adapter kit

Download CAD data → www.festo.com

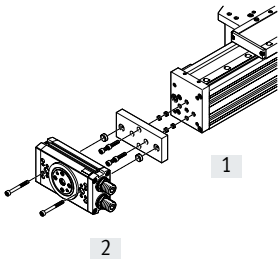
| Combination | [1] Drive Size | [2] Drive Size | Adapter kit CRC ¹⁾ | Part no. | Type | Quantity required | | |
|--|----------------|---------------------------------------|-------------------------------|-------------|------------------------------|-------------------|-----------------------|---|
| ELCC/DRRD | ELCC | DRRD | DHAA | | | | | |
|  | 60 | 10 | 2 | 2737394 | DHAA-D-G6-8/10-Q11-10 | 1 | | |
| | 60 | 12 | | 2736429 | DHAA-D-G6-8/10-Q11-12 | | | |
| | 60 | 16 | | 1675259 | DHAA-D-E2-18-Q11-16 | | | |
| | 60, 70 | 20 | | 1679833 | DHAA-D-E2-18/25-Q11-20 | | | |
| | 60, 70 | 25 | | 1696421 | DHAA-D-E2-25-Q11-25 | | | |
| | 70 | 32 | | 1702297 | DHAA-D-E2-25-Q11-32 | | | |
| | 70, 90 | 32 | | 5154625 | DHAA-D-E21-70...110-Q11-32 | | | |
| | 70, 90 | 35 | | 5154627 | DHAA-D-E21-70...110-Q11-35 | | | |
| | 90, 110 | 40 | | 5154629 | DHAA-D-E21-70...110-Q11-40 | | | |
| | 90, 110 | 50 | | 5154639 | DHAA-D-E21-70...110-Q11-50 | | | |
| | 110 | 63 | | 5154642 | DHAA-D-E21-70...110-Q11-63 | | | |
| | ELCC | DRRD-...-P...E...²⁾ | | DHAA | | | | |
| | 60 | 16 | | 2 | 2328624 | | DHAA-D-E2-18-Q11-16-E | 1 |
| | 60, 70 | 20 | 2328779 | | DHAA-D-E2-18/25-Q11-20-E | | | |
| | 60, 70 | 25 | 2328793 | | DHAA-D-E2-25-Q11-25-E | | | |
| | 70 | 32 | 2328805 | | DHAA-D-E2-25-Q11-32-E | | | |
| | 70, 90 | 32 | 5154626 | | DHAA-D-E21-70...110-Q11-32-E | | | |
| | 70, 90 | 35 | 5154628 | | DHAA-D-E21-70...110-Q11-35-E | | | |
| | 90, 110 | 40 | 5154630 | | DHAA-D-E21-70...110-Q11-40-E | | | |
| 90, 110 | 50 | 5154640 | DHAA-D-E21-70...110-Q11-50-E | | | | | |
| 110 | 63 | 5154643 | DHAA-D-E21-70...110-Q11-63-E | | | | | |

1) Corrosion resistance class CRC 2 to Festo standard FN 940070

Moderate corrosion stress. Indoor applications in which condensation can occur. External visible parts with primarily decorative surface requirements which are in direct contact with a normal industrial environment.

2) With energy through-feed

Accessories

Adapter kit
DHAA, HAPG

Material:
Wrought aluminium alloy
Free of copper and PTFE
RoHS-compliant

**Note**

The kit includes the individual mounting interface as well as the necessary mounting material.

Permissible drive/drive combinations with adapter kit

Download CAD data → www.festo.com

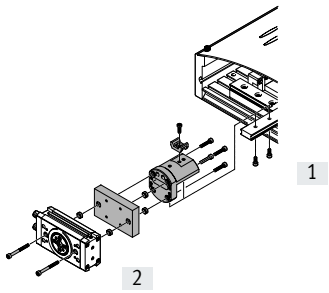
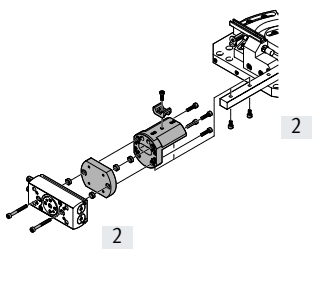
| Combination | [1] Drive Size | [2] Drive Size | Adapter kit CRC ¹⁾ | Part no. | Type | Quantity required |
|---|----------------|---------------------------------------|-------------------------------|-------------------------|---------------------------|-------------------|
|  | HSP | DRRD | DHAA | | | |
| | 12 | 8 | 2 | 2786084 | DHAA-D-H4-12-Q11-8 | 1 |
| | | | - | 540881 | HAPG-70-B | |
| | 16 | 10 | 2 | 2785801 | DHAA-D-H4/H5-12/16-Q11-10 | |
| | | | - | 540882 | HAPG-71-B | |
| | 16 | 12 | 2 | 2784113 | DHAA-D-H4/H5-16/25-Q11-12 | |
| | | | - | 540882 | HAPG-71-B | |
| | 25 | 12 | 2 | 2784113 | DHAA-D-H4/H5-16/25-Q11-12 | |
| | | | - | 540883 | HAPG-72-B ³⁾ | |
| | 25 | 16 | 2 | 1919910 | DHAA-D-H4-25-Q11-16 | |
| | | | - | 540883 | HAPG-72-B ³⁾ | |
| | HSP | DRRD-...-P...E...²⁾ | DHAA | | | |
| 25 | 16 | 2 | 2284940 | DHAA-D-H4-25-Q11-16-E | 1 | |
| | | - | 540883 | HAPG-72-B ³⁾ | | |
|  | HSW | DRRD | DHAA | | | |
| | 10 | 8 | 2 | 2789655 | DHAA-D-H5-10-Q11-8 | 1 |
| | | | - | 540249 | HAPG-69 | |
| | 12 | 8 | 2 | 2788114 | DHAA-D-H5-12-Q11-8 | |
| | | | - | 540882 | HAPG-71-B | |
| | 12 | 10 | 2 | 2785801 | DHAA-D-H4/H5-12/16-Q11-10 | |
| | | | - | 540882 | HAPG-71-B | |
| | 16 | 10 | 2 | 2785801 | DHAA-D-H4/H5-12/16-Q11-10 | |
| | | | - | 540882 | HAPG-71-B | |
| | 16 | 12 | 2 | 2784113 | DHAA-D-H4/H5-16/25-Q11-12 | |
| | | - | 540882 | HAPG-71-B | | |

1) Corrosion resistance class CRC 2 to Festo standard FN 940070

Moderate corrosion stress. Indoor applications in which condensation can occur. External visible parts with primarily decorative surface requirements which are in direct contact with a normal industrial environment.

2) With energy through-feed

3) The centring sleeves for attaching to the adapter kit HAPG-72-B are not required