







Olympian Plus plug-in system

R64G, R68G Pressure regulators

G1/4 to G1 1/2

Accessories

Series	Port size	Bracket kit	Bracket kit	Gauge 0 ... 10 bar*	3/2 Shut-off valve	Panel nut	Tamper resistant kit
							
R64G	G1/4	–	74504-50	18-013-013	T64T-2GB-P1N	4348-89	4355-50
	G3/8	–	74504-50	18-013-013	T64T-3GB-P1N	4348-89	4355-50
	G1/2	–	74504-50	18-013-013	T64T-4GB-P1N	4348-89	4355-50
	G3/4	–	74504-50	18-013-013	T64T-6GB-P1N	4348-89	4355-50
R68G	G3/4	18-001-979	–	18-013-013	T68C-6GB-B2N	–	4355-50
	G1	18-001-979	–	18-013-013	T68C-8GB-B2N	–	4355-50
	G1 1/4	18-001-978	–	18-013-013	T68C-AGB-B2N	–	4355-50
	G1 1/2	–	–	18-013-013	T68C-BGB-B2N	–	4355-50

* Other pressure ranges available – see page 486

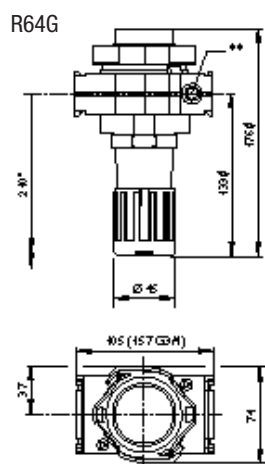

* Minimum clearance required to remove unit from yoke.
Reduces by 4 mm with knob in locked position.

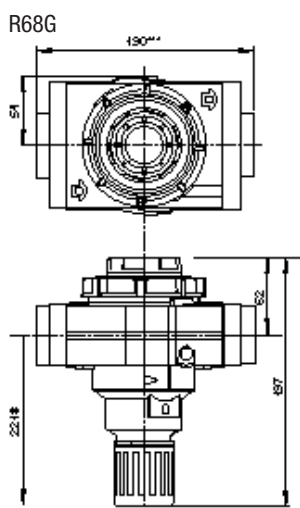

Minimum clearance required to remove unit from yoke
*** For 1 1/4" and 1 1/2" ported yokes add 10 mm
Panel mounting hole Ø: 52 mm
Panel thickness: 0 ... 6 mm

Bracket mounting (R64G)

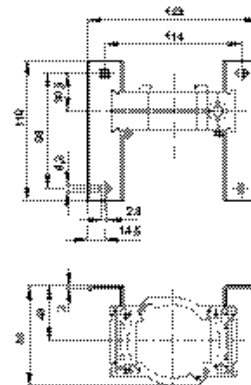

Bracket mounting (R68G)

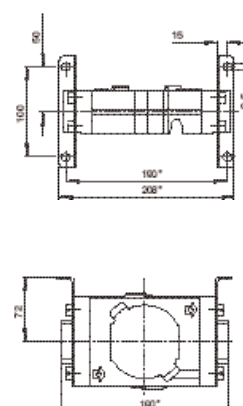

Flow characteristics

