

# Cylinders Series 61 - Aluminium profile

1

Single, double-acting, magnetic, cushioned  
 ø 32, 40, 50, 63, 80, 100, 125 (DIN/ISO 6431)



- » DIN/ISO 6431/VDMA 24562
- » Rolled stainless steel rod
- » Clean design
- » Adjustable pneumatic cushioning

The Series 61 cylinders have been designed to comply with the dimensions laid down in the DIN/ISO 6431 standards. A permanent magnet is mounted on the piston in these cylinders which enables information to be received regarding the pistons position, by means of proximity switches mounted in grooves along the cylinder profile. These grooves can be covered with a slot cover profile Mod.S-CST-500.

This cylinder series is equipped with adjustable end-stroke cushioning. Moreover, these cylinders are equipped with a mechanical cushioning in order to reduce the impact of the piston as it reaches the end of the stroke.

## GENERAL DATA

<b>Type of construction</b>	with tie-rods (inside the profile)
<b>Operation</b>	double-acting, single-acting, tandem
<b>Materials</b>	aluminium end-blocks, NBR seals, PU rod, other parts see coding
<b>Type of mounting</b>	with tie-rods, front flange, rear flange, feet front and rear trunnion, swivel combination
<b>Stroke min - max</b>	10 + 2500mm
<b>Operating temperature</b>	0°C + 80°C (with dry air -20°C)
<b>Special designs</b>	see coding example
<b>Operating pressure</b>	1 + 10 bar
<b>Speed</b>	10 + 1000 mm/sec (NO LOAD)
<b>Fluid</b>	clean air, lubrication if lubricated air is used, it is recommended to use oil ISOVG32. Once applied the lubrication should never be interrupted.

**STANDARD STROKES FOR CYLINDERS SERIES 61**

■ = Single acting  
 ✕ = Double acting

∅	25	50	75	80	100	125	150	160	200	250	300	320	400	500
32	■ ✕	■ ✕	■ ✕	✕	✕	✕	✕	✕	✕	✕	✕	✕	✕	✕
40	■ ✕	■ ✕	■ ✕	✕	✕	✕	✕	✕	✕	✕	✕	✕	✕	✕
50	■ ✕	■ ✕	■ ✕	✕	✕	✕	✕	✕	✕	✕	✕	✕	✕	✕
63	■ ✕	■ ✕	■ ✕	✕	✕	✕	✕	✕	✕	✕	✕	✕	✕	✕
80	■ ✕	■ ✕	■ ✕	✕	✕	✕	✕	✕	✕	✕	✕	✕	✕	✕
100		■ ✕	■ ✕	✕	✕	✕	✕	✕	✕	✕	✕	✕	✕	✕
125		■ ✕	■ ✕	✕	✕	✕	✕	✕	✕	✕	✕	✕	✕	✕

**CODING EXAMPLE**

<b>61</b>	<b>M</b>	<b>2</b>	<b>P</b>	<b>050</b>	<b>A</b>	<b>0200</b>	<b>-</b>
-----------	----------	----------	----------	------------	----------	-------------	----------

<b>61</b>	SERIES
<b>M</b>	VERSION M= standard, magnetic
<b>2</b>	OPERATION 1 = single-acting (front spring) (∅32 +∅100) 2 = double-acting 3 = double-acting (no cushion) 4 = double-acting (rear cushion) 5 = double-acting (front cushion) 6 = double-acting 7 = single-acting, through rod
<b>P</b>	MATERIALS P = rolled stainless steel rod AISI 420B - anodized profile aluminium tube - NBR seals - nuts and tie-rods zinc-plated steel - rod seals PU R = rolled stainless steel rod AISI 420B - anodized profile aluminium tube - NBR seals - nuts stainless steel AISI 303 - tie-rods stainless steel AISI 420B - rod seals PU
<b>050</b>	BORE 32 mm 40 mm 50 mm 63 mm 80 mm 100 mm 125 mm
<b>A</b>	CONSTRUCTION A = standard lock nut for rod RL = cylinder with rod lock
<b>0200</b>	STROKE (see table)
<b>-</b>	= standard V = rod seal FKM N = tandem R = rod seal NBR W = all seals FKM + 130 C°



**CYLINDERS ACCESSORIES SERIES 61**



Piston rod socket joint Mod. GY



Piston rod lock nut Mod. U



Clevis pin Mod. S

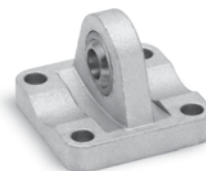

Rear trunnion ball-joint Mod. R



Coupling piece Mod. GKF (New)



Swivel ball joint Mod. GA

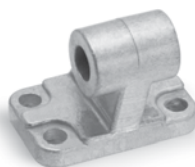

90° male trunnion Mod. ZC



Swivel Combination Mod. C+L+S

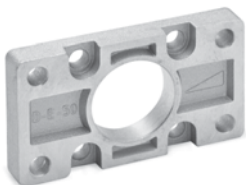

Front and rear flange Mod. D-E



Self aligning rod Mod. GK (New)



Centre trunnion Mod. F



Foot mount Mod. B

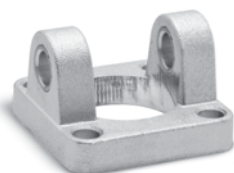

Front female trunnion Mod. H and CH



All accessories are supplied separately, except for piston rod lock nut Mod. U

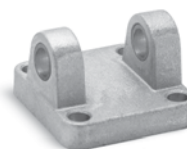

Rear female trunnion Mod. C and CH



Rod fork end Mod. G

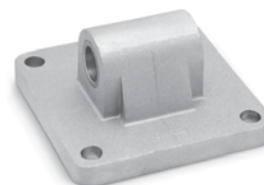

Rear trunnion male Mod. L

Cylinders Series 61

N.B. : the single-acting cylinders' sizes L1 and L2 are increased by 25 mm.



+ = add the stroke

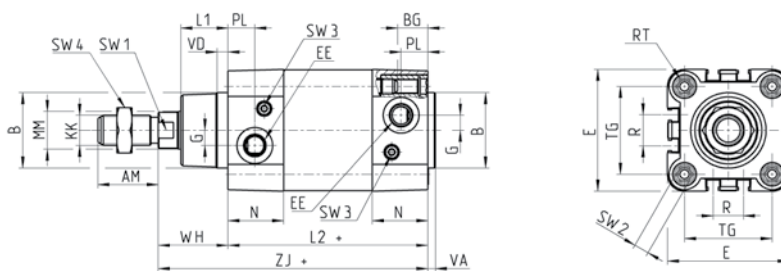

DIMENSIONS

∅	MM	KK	B	PL	L1	AM	VA	EE	WH	L2+	ZJ+	VD	N	BG	RT	G	TG	R	E	SW1	SW2	SW3	SW4	front and rear cushion stroke
32	12	M10x1,25	30	14	18	22	4	G1/8	26	94	120	5	26	16	M6	5	32,5	13	46	10	6	2	17	17 / 12
40	16	M12x1,25	35	15	21	24	4	G1/4	30	105	135	5	29	16	M6	5	38	13,5	55	13	6	2	19	20 / 17
50	20	M16x1,5	40	15	25	32	4	G1/4	37	106	143	6	29,5	16	M8	8	46,5	16	64,5	17	8	3	24	15 / 14
63	20	M16x1,5	45	21	26	32	4	G3/8	37	121	158	6	36,5	16	M8	8	56,5	28	75	17	8	3	24	17 / 16
80	25	M20x1,5	45	21	30	40	4	G3/8	46	128	174	7	36	19	M10	8	72	30	93	22	10	5	30	20 / 20
100	25	M20x1,5	55	23	35	40	4	G1/2	51	138	189	7	38,5	19,5	M10	8	89	40	110	22	10	5	30	21 / 19
125	32	M27x2	60	23,5	42	54	6	G1/2	65	160	225	8	43	23	M12	10,5	110	50	135	27	12	4	41	26 / 25

Cylinders Series 61

Through rod

N.B. : the single-acting cylinders' sizes L1 and L2 are increased by 25 mm.



+ = add the stroke  
++ = add the stroke two times

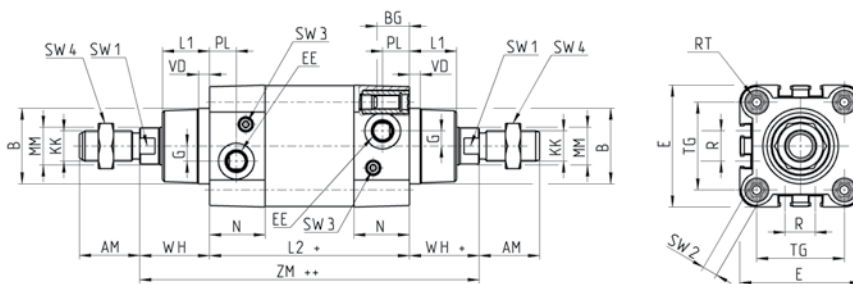

DIMENSIONS

∅	MM	KK	B	PL	L1	AM	EE	WH	L2+	ZM++	VD	N	BG	RT	G	TG	R	E	SW1	SW2	SW3	SW4	front and rear cushion stroke
32	12	M10x1,25	30	14	18	22	G1/8	26	94	146	5	26	16	M6	5	32,5	13	46	10	6	2	17	17 / 12
40	16	M12x1,25	35	15	21	24	G1/4	30	105	165	5	29	16	M6	5	38	13,5	55	13	6	2	19	20 / 17
50	20	M16x1,5	40	15	25	32	G1/4	37	106	180	6	29,5	16	M8	8	46,5	16	64,5	17	8	3	24	15 / 14
63	20	M16x1,5	45	21	26	32	G3/8	37	121	195	6	36,5	16	M8	8	56,5	28	75	17	8	3	24	17 / 16
80	25	M20x1,5	45	21	30	40	G3/8	46	128	220	7	36	19	M10	8	72	30	93	22	10	5	30	20 / 20
100	25	M20x1,5	55	23	35	40	G1/2	51	138	240	7	38,5	19,5	M10	8	89	40	110	22	10	5	30	21 / 19
125	32	M27x2	60	23,5	42	54	G1/2	65	160	290	8	43	23	M12	10,5	110	50	135	27	12	4	41	26 / 25

Cylinders Series 61 tandem



+ = add the stroke  
 ++ = add the stroke two times

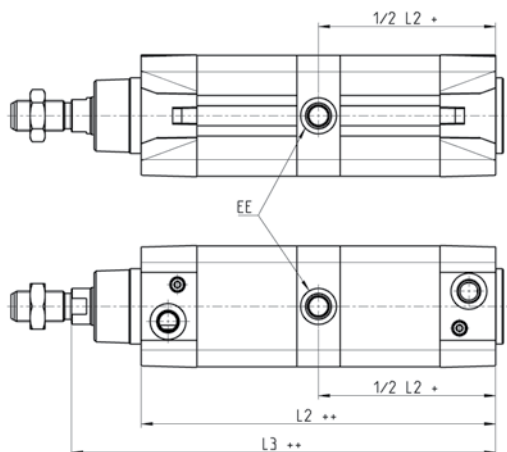

DIMENSIONS

∅	EE	L2+	L3+
32	G1/8	172,5	197,5
40	G1/4	191,5	221,5
50	G1/4	188	225
63	G3/8	204	230
80	G3/8	225,5	271,5
100	G1/2	231	282
125	G1/2	264	329

Cylinders Series 61 with rod lock



+ = add the stroke

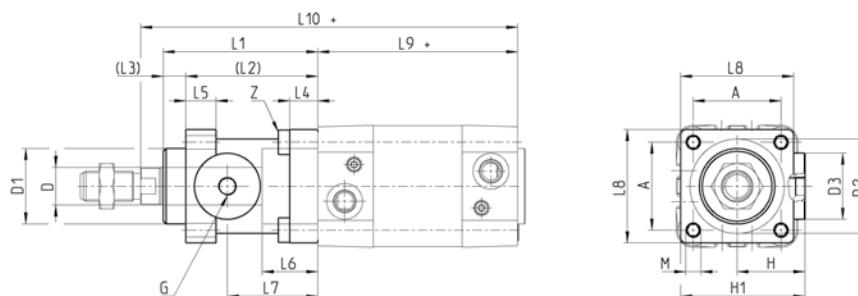

DIMENSIONS

∅	L1	L2	L3	L4	L5	L6	L7	L8	L9+	L10+	∅D	∅D1	∅D2	∅D3	A	G	H	H1	M	Z
32	58	48	10	8	13	20,5	34	45	94	160	12	30,5	35	25	32,5	M5	25,5	46,5	M6	M6x20
40	65	55	10	8	13	22,5	38	50	105	178	16	35	40	28	38	G1/8	30	53	M6	M6x20
50	82	70	12	15	16	29,5	48	60	106	200	20	40	50	35	46,5	G1/8	36	64	M8	M6x20
63	82	70	12	15	16	29,5	49,5	70	121	215	20	45	60	38	56,5	G1/8	40	75	M8	M8x30
80	110	90	20	18	20	35	61	90	128	254	25	45	80	48	72	G1/8	50	95	M10	M10x35
100	115	100	15	18	20	39	69	105	138	269	25	55	100	58	89	G1/8	58	110,5	M10	M10x35
125	167	122	45	22	30	51	86,5	140	160	350	32	60	130	65	110	G1/8	80	150	M12	M12x40

The company reserves the right to vary models and dimensions without notice.  
 Products designed for industrial applications. Sale to general public is forbidden.

Foot mount Mod. B

Material: zinc-plated steel



Supplied with:  
2x feet  
4x screws

+ = add the stroke

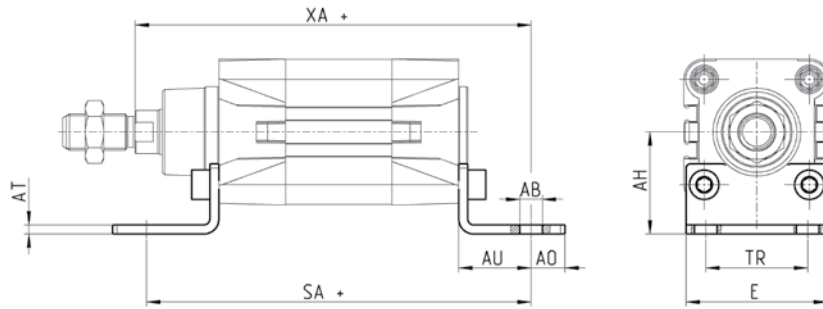

DIMENSIONS

Mod.	∅	AT	SA+	XA+	TR	E	AB	AH	AO	AU
<b>B-41-32</b>	32	4	142	144	32	45	7	32	11	24
<b>B-41-40</b>	40	4	161	163	36	53,5	10	36	15	28
<b>B-41-50</b>	50	4	170	175	45	62,5	10	45	15	32
<b>B-41-63</b>	63	5	185	190	50	73	10	50	15	32
<b>B-41-80</b>	80	6	210	216	63	92	12	63	20	41
<b>B-41-100</b>	100	6	220	230	75	108,5	14,5	71	25	41
<b>B-41-125</b>	125	7	250	270	90	132	16,5	90	25	45

Front and rear flange Mod. D-E

Material: aluminium

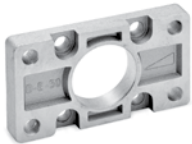

Supplied with:  
1x flange  
4x screws

+ = add the stroke

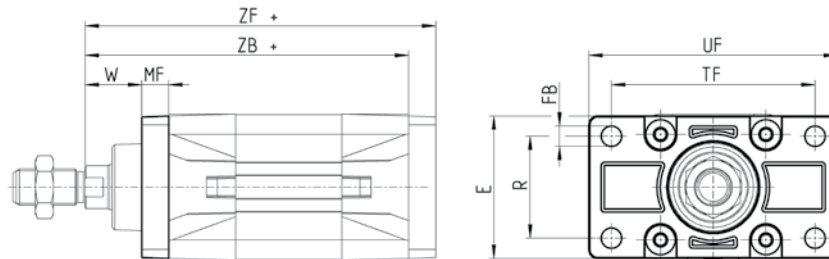

DIMENSIONS

Mod.	∅	W	MF	ZB+	TF	R	UF	E	FB	ZF+	torque force
<b>D-E-41-32</b>	32	16	10	120	64	32	86	45	7	130	6 Nm
<b>D-E-41-40</b>	40	20	10	135	72	36	88	52	9	145	6 Nm
<b>D-E-41-50</b>	50	25	12	143	90	45	110	63	9	155	13 Nm
<b>D-E-41-63</b>	63	25	12	158	100	50	116	73	9	170	13 Nm
<b>D-E-41-80</b>	80	30	16	174	126	63	148	95	12	190	19 Nm
<b>D-E-41-100</b>	100	35	16	189	150	75	176	115	14	205	22 Nm
<b>D-E-41-125</b>	125	45	20	225	180	90	224	135	16	245	26 Nm

Rear trunnion female Mod. C and C-H

Material: aluminium



Supplied with:  
N° female trunnion  
N° screws

+ = add the stroke

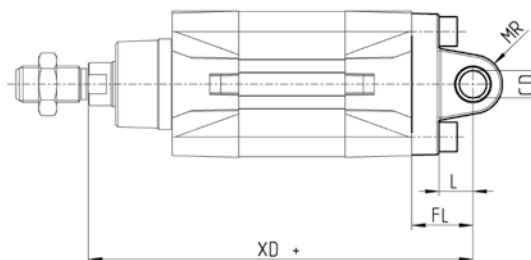
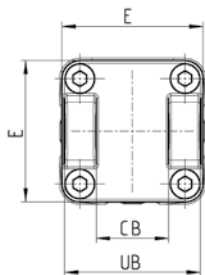

DIMENSIONS

Mod.	∅	CD	L	FL	XD+	MR	E	CB	UB	torque force
<b>C-41-32</b>	32	10	12	22	142	10	45	26	45	6 Nm
<b>C-41-40</b>	40	12	15	25	160	13	52	28	52	6 Nm
<b>C-41-50</b>	50	12	15	27	170	13	63	32	60	13 Nm
<b>C-H-41-63</b>	63	16	20	32	190	15	73	40	70	13 Nm
<b>C-H-41-80</b>	80	16	24	36	210	15	95	50	90	19 Nm
<b>C-H-41-100</b>	100	20	29	41	230	18	115	60	110	26 Nm
<b>C-H-41-125</b>	125	25	30	50	275	25	135	70	130	26 Nm

Front trunnion female Mod. H and C-H

Material: aluminium

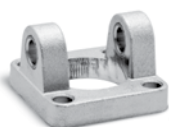

Supplied with:  
1x female trunnion  
4x screws

+ = add the stroke

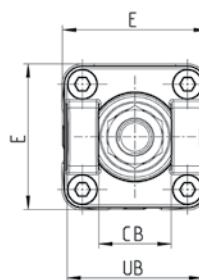
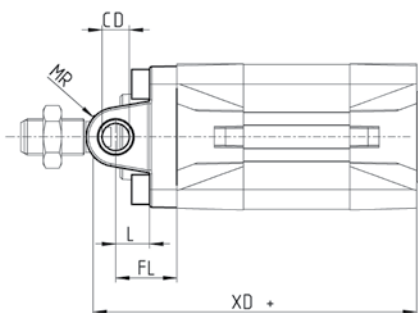

DIMENSIONS

Mod.	∅	CB	UB	E	XD	FL	L	CD	MR
<b>H-41-32</b>	32	26	45	45	120	22	12	10	10
<b>H-41-40</b>	40	28	52	52	135	25	15	12	13
<b>H-41-50</b>	50	32	60	63	143	27	15	12	13
<b>H-60-63</b>	63	40	70	73	158	32	20	16	15
<b>C-H-41-80</b>	80	50	90	95	174	36	24	16	15
<b>C-H-41-100</b>	100	60	110	115	189	41	29	20	18
<b>C-H-41-125</b>	125	70	130	135	225	50	30	25	25

Rear trunnion, male Mod. L

Material: aluminium



Supplied with:  
1x male trunnion  
4x screws

+ = add the stroke

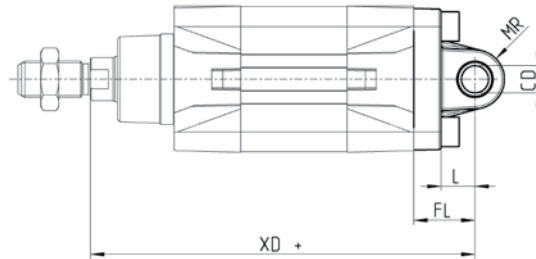
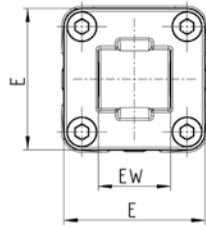

DIMENSIONS

Mod.	Ø	CD	L	FL	XD+	MR	E	EW	torque force
L-41-32	32	10	12	22	142	9	45	26	6 Nm
L-41-40	40	12	15	25	160	13	52	28	6 Nm
L-41-50	50	12	15	27	170	13	63	32	13 Nm
L-41-63	63	16	20	32	190	15	73	40	13 Nm
L-41-80	80	16	24	36	210	15	95	50	19 Nm
L-41-100	100	20	29	41	230	18	115	60	22 Nm
L-41-125	125	25	30	50	275	25	135	70	26 Nm

Centre trunnion Mod. F

Material: zinc-plated steel



Supplied with:  
1x centre trunnion  
4x screws  
4x fixing elements

+ = add the stroke

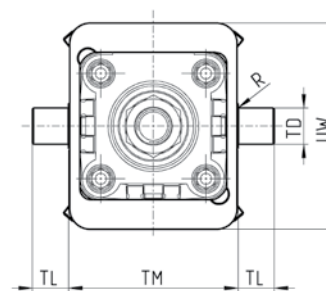
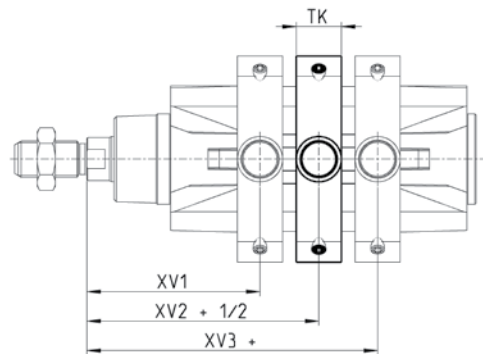

DIMENSIONS

Mod.	Ø	XV1	XV2	XV3	TM	TK	TD	TL	UW	R
F-61-32	32	61	73	85	50	18	12	12	70	0,1
F-61-40	40	69	82,5	96	63	20	16	16	78	0,15
F-61-50	50	76,5	90	103,5	75	20	16	16	91	0,15
F-61-63	63	86	97,5	109	90	25	20	20	94	0,15
F-61-80	80	94,5	110	125,5	110	25	20	20	130	0,15
F-61-100	100	104,5	120	135,5	132	30	25	25	145	0,2
F-61-125	125	123	145	167	160	30	25	25	155	0,2



Accessory combination Mod. C+L+S

Material: aluminium



+ = add the stroke

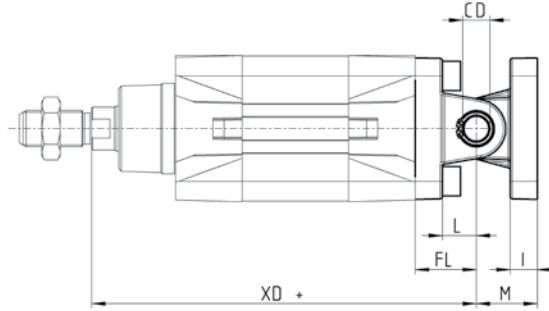
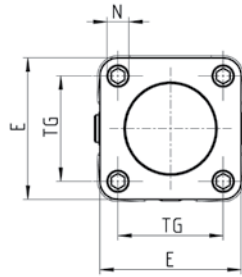

DIMENSIONS

Mod.	∅	∅CD	L	FL	XD+	MR	E	CB	UB	torque force
<b>C+L+S</b>	32	10	12	22	142	10	45	26	45	6 Nm
<b>C+L+S</b>	40	12	15	25	160	10	52	28	52	6 Nm
<b>C+L+S</b>	50	12	15	27	170	13	63	32	60	13 Nm
<b>C+L+S</b>	63	16	20	32	190	15	73	40	70	13 Nm
<b>C+L+S</b>	80	16	24	36	210	15	95	50	90	19 Nm
<b>C+L+S</b>	100	20	29	41	230	18	115	60	110	26 Nm
<b>C+L+S</b>	125	25	30	50	275	25	135	70	130	26 Nm

90° male trunnion Mod. ZC

CETOP RP 107P

Material: aluminium



Supplied with:  
1x male support

+ = add the stroke

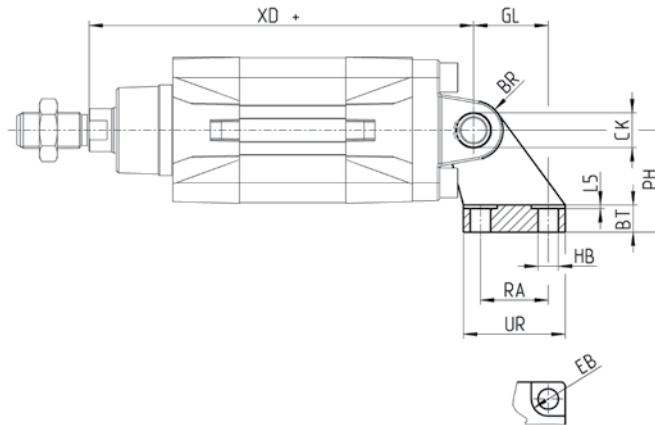
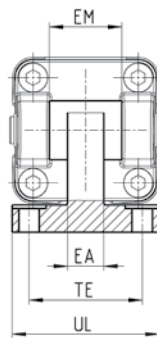

DIMENSIONS

Mod.	∅	EB	CK	HB	XD+	TE	UL	EA	GL	L5	RA	EM	UR	PH	BT	BR
<b>ZC-32</b>	32	11	10	6,6	142	38	51	10	21	1,6	18	26	31	32	8	10
<b>ZC-40</b>	40	11	12	6,6	160	41	54	15	24	1,6	22	28	35	36	10	11
<b>ZC-50</b>	50	15	12	9	170	50	65	16	33	1,6	30	32	45	45	12	13
<b>ZC-63</b>	63	15	16	9	190	52	67	16	37	1,6	35	40	50	50	12	15
<b>ZC-80</b>	80	18	16	11	210	66	86	20	47	2,5	40	50	60	63	14	15
<b>ZC-100</b>	100	18	20	11	230	76	96	20	55	2,5	50	60	70	71	15	19
<b>ZC-125</b>	125	20	25	14	275	94	124	30	70	2,5	60	70	90	90	20	22,5

**Trunnion ball-joint Mod. R**

Material: aluminium  
Not according to standard

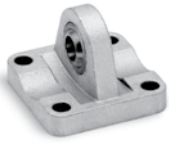

Supplied with:  
1x trunnion ball joint  
4x screws

+ = add the stroke

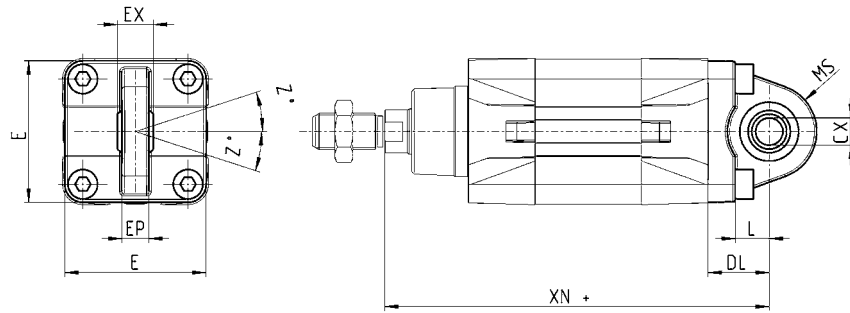

**DIMENSIONS**

Mod.	∅	CX	L	DL	XN+	MS	E	EX	EP	Z	torque force
<b>R-41-32</b>	32	10	12	22	142	16	45	14	10,5	4	6 Nm
<b>R-41-40</b>	40	12	15	25	160	20	52	16	12	4	6 Nm
<b>R-41-50</b>	50	12	15	27	170	20	63	16	12	4	13 Nm
<b>R-41-63</b>	63	16	20	32	190	24	73	21	15	4	13 Nm
<b>R-41-80</b>	80	16	24	36	210	24	95	21	15	4	19 Nm
<b>R-41-100</b>	100	20	29	41	230	30	115	25	18	4	22 Nm
<b>R-41-125</b>	125	30	30	50	275	40	140	37	25	4	26 Nm

**Counter bracket for centre trunnion Mod. BF**

Material: aluminium



Supplied with:  
2x supports

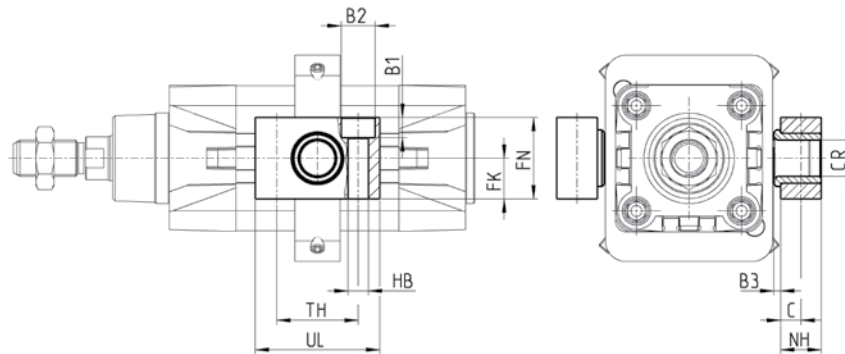

**DIMENSIONS**

Mod.	∅	CR	NH	C	B3	TH	UL	FK	FN	B1	B2	HB
<b>BF-32</b>	32	12	15	7,5	3	32	46	15	30	6,8	11	6,6
<b>BF-40-50</b>	40 - 50	16	18	9	3	36	55	18	36	9	15	9
<b>BF-63-80</b>	63 - 80	20	20	10	3	42	65	20	40	11	18	11
<b>BF-100-125</b>	100 - 125	25	25	12,5	3,5	50	75	25	50	13	20	14

Accessory to mount valves on the cylinder

The mounting subbase Mod. PCV, enable the valve or solenoid valve to be mounted directly on the cylinder.

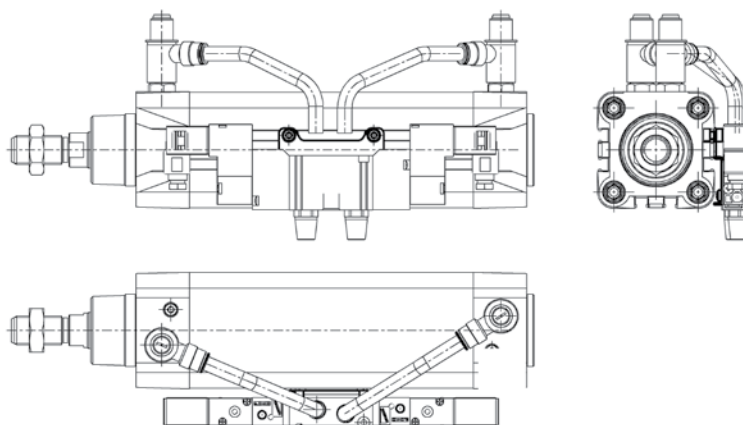

DIMENSIONS

Mod.	
<b>PCV-61-K3</b>	to connect valves - solenoid valves Series 3
<b>PCV-61-K4</b>	to connect valves - solenoid valves Series 4 port G1/4
<b>PCV-61-KE</b>	to connect valves - solenoid valves Series E
<b>PCV-61-K8</b>	to connect valves - solenoid valves Series 4 port G1/8 and Series 3 port G1/4

Clevis pin Mod. S



Supplied with:  
1x clevis pin (stainless steel 303)  
2x Seeger (steel)

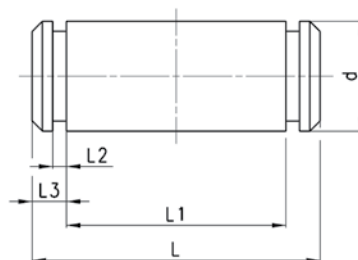

DIMENSIONS

Mod.	Ø	d	L	L1	L2	L3
<b>S-32</b>	32	10	52	46	1,1	3
<b>S-40</b>	40	12	59	53	1,1	3
<b>S-50</b>	50	12	67	61	1,1	3
<b>S-63</b>	63	16	77	71	1,1	3
<b>S-80</b>	80	16	97	91	1,1	3
<b>S-100</b>	100	20	121	111	1,3	5
<b>S-125</b>	125	25	140,5	132	1,3	4,25

Swivel ball joint Mod. GA

ISO 8139.  
Material: zinc-plated steel.

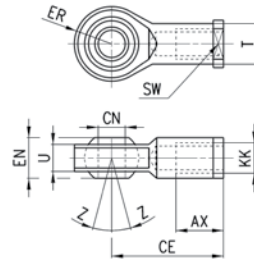

DIMENSIONS										
Mod.	øCN	U	EN	ER	AX	CE	KK	T	Z	SW
GA-32	10	10,5	14	14	20	43	M10X1,25	15	6,5	17
GA-40	12	12	16	16	22	50	M12X1,25	17,5	6,5	19
GA-50-63	16	15	21	21	28	64	M16X1,5	22	7,5	22
GA-80-100	20	18	25	25	33	77	M20x1,5	27,5	7	30
GA-41-125	30	25	37	37	51	110	M27x2	40	7,5	41

Piston rod socket joint Mod. GY

Material: zama and zinc-plated steel.

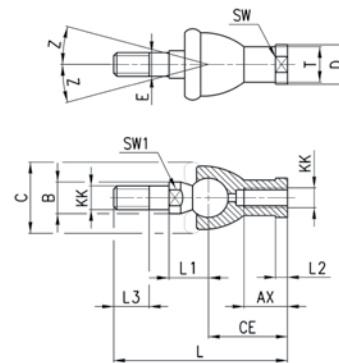

DIMENSIONS																
Mod.	Ø	KK	L	CE	L2	AX	SW	SW1	L1	L3	øT	øD	E	øB	øC	Z
GY-32	32	M10X1,25	74	35	6,5	18	17	11	19,5	15	15	19	10	14	28	15
GY-40	40	M12X1,25	84	40	6,5	20	19	17	22	17	17,5	22	12	19	32	15
GY-50-63	50-63	M16X1,5	112	50	8	27	22	23	27,5	23	22	27	16	22	40	11
GY-80-100	80-100	M20x1,5	133	63	10	38	30	25	31,5	25	27,5	34	20	29	45	7,5

Rod fork end Mod. G

Material: zinc-plated steel  
ISO 8140

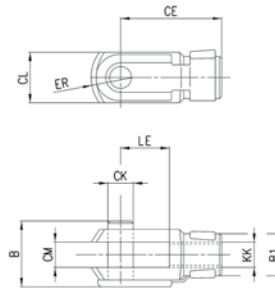

DIMENSIONS									
Mod.	øCK	LE	CM	CL	ER	CE	KK	B	B1
G-25-32	10	20	10	20	12	40	M10 X 1,25	26	18
G-40	12	24	12	24	14	48	M12 X 1,25	32	20
G-50-63	16	32	16	32	19	64	M16 X 1,5	40	26
G-80-100	20	40	20	40	25	80	M20 X 1,5	48	34
G-41-125	30	55	30	55	28	110	M27 X 2	74	48

Piston rod lock nut Mod. U

UNI EN ISO 4035.  
Material: zinc-plated steel.

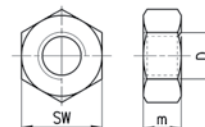

DIMENSIONS			
Mod.	D	m	SW
U-25-32	M10X1,25	6	17
U-40	M12X1,25	7	19
U-50-63	M16X1,5	8	24
U-80-100	M20x1,5	9	30
U-41-125	M27x2	12	41

Self aligning rod Mod. GK

New

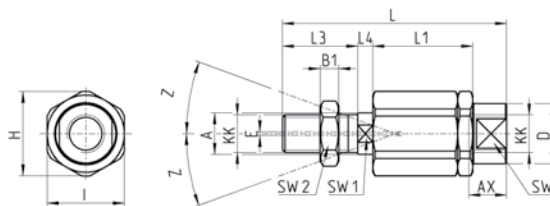

DIMENSIONS																	
Mod.	∅	KK	L	L1	L3	L4	A	∅D	H	I	SW	SW1	SW2	B1	AX	Z	E
<b>GK-25-32</b>	25-32	M10x1,25	71,5	35	20	7,5	14	22	32	30	19	12	17	5	22	4	2
<b>GK-40</b>	40	M12x1,25	75,5	35	24	7,5	14	22	32	30	19	12	19	6	22	4	2
<b>GK-50-63</b>	50-63	M16x1,5	104	53	32	10	22	32	45	41	27	20	24	8	30	3	2
<b>GK-80-100</b>	80-100	M20x1,5	119	53	40	10	22	32	45	41	27	20	30	10	37	3	2

Coupling piece Mod. GKF

New

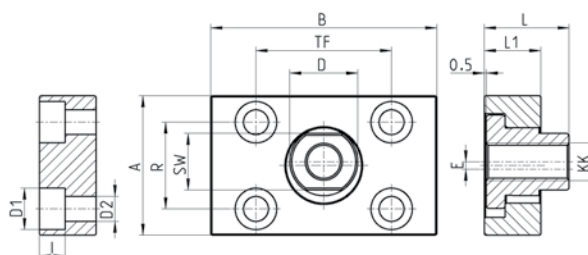
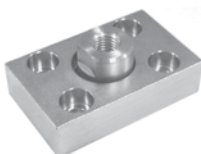

DIMENSIONS														
Mod.	∅	KK	A	B	R	TF	L	L1	I	∅ D	∅ D1	∅ D2	SW	E
<b>GKF-25-32</b>	32	M10x1,25	37	60	23	36	22,5	15	6,8	18	11	6,6	15	2
<b>GKF-40</b>	40	M12x1,25	56	60	38	42	22,5	15	9	20	15	9	15	2,5
<b>GKF-50-63</b>	50-63	M16x1,5	80	80	58	58	26,5	15	10,5	25	18	11	22	2,5
<b>GKF-80-100</b>	80-100	M20x1,5	90	90	65	65	32,5	20	13	30,5	20	14	27	2,5
<b>GKF-125</b>	125	M27x2	90	90	65	65	35,5	20	13	40	20	14	36	4