



# PIPECLAMPS

## PIPECLAMP FITTINGS

Pipeclamp fittings are a blackheart malleable casting and are manufactured to BS EN 1562 1997 for the strength requirements. Pipeclamp fittings are hot dip galvanised to BS EN 1461 1999.

Pipeclamp fittings are supplied with electro plated case hardened grubscrews. The only tool required to tighten the grubscrew is a simple allen key. When tightened to a torque of 4.1kg/m (29ft/lb), the grubscrew is capable of withstanding an applied slip load of 900kg. This torque cannot be achieved using an allen key, but can be obtained when the grubscrew is fully tightened using a ratchet key, Pipeclamp fitting reference 233.

Pipeclamp fittings are available in the standard sizes 1-5 as detailed in this brochure. If a Pipeclamp fitting reference number does not include a tube reference number then this fitting size is not available at the time of printing.

## SELECTING A PIPECLAMP FITTING

Selecting a Pipeclamp fitting is very simple. Using the information in the brochure, select the fitting to suit the task required, select the size of tube that is suitable then combine the two reference numbers.

ie. A short inline tee using 42.4mm tube = 101-3

Whilst the information and guidelines in this brochure are given as a guidance, the ultimate responsibility for selecting the correct fitting and size for any application belongs to the customer. The customer must also ensure that any structure or construction is of sufficient strength to support the weight of the Pipeclamp fittings and tube as well as any applied load.

Full technical support and assistance is available upon request.

## FINISHES

The standard finish of Pipeclamp fittings and associated tubing is hot dipped galvanised. Pipeclamp fittings can also be supplied polyester powder coated in a range of RAL or BS colours. The polyester powder coating is applied over the galvanised finish.

## AVAILABILITY

Pipeclamp fittings are available from authorised stockists around the Country. For details of your nearest stockist or if you are in doubt about the correct way of reading this brochure or interpreting any information within this brochure please contact GWS Products Ltd.

## HEALTH AND SAFETY CONTROL OF SUBSTANCES HAZARDOUS TO HEALTH REGULATIONS 1988

GWS Products Ltd have and continue to investigate the Pipeclamp fittings and associated tubing. None are considered to be hazardous within the meaning of the regulations provided that the tube is cut using pipecutters or saws and the Pipeclamp fittings are tightened with the proprietary allen or ratchet key.

Any welding will have COSHH implications, especially if any surface is pre finished, i.e. galvanised, painted, powder coated etc.

GWS Products Ltd do not recommend that Pipeclamp fittings are welded.

Whilst every effort has been taken to ensure that the information contained in this brochure is correct, GWS Products Ltd reserve the right to alter and revise this information as and when considered necessary in line with their on-going policy of product research and development.

Users of Pipeclamp fittings are reminded that no part of this brochure may be reproduced in any form without prior permission in writing.

# PIPECLAMPS

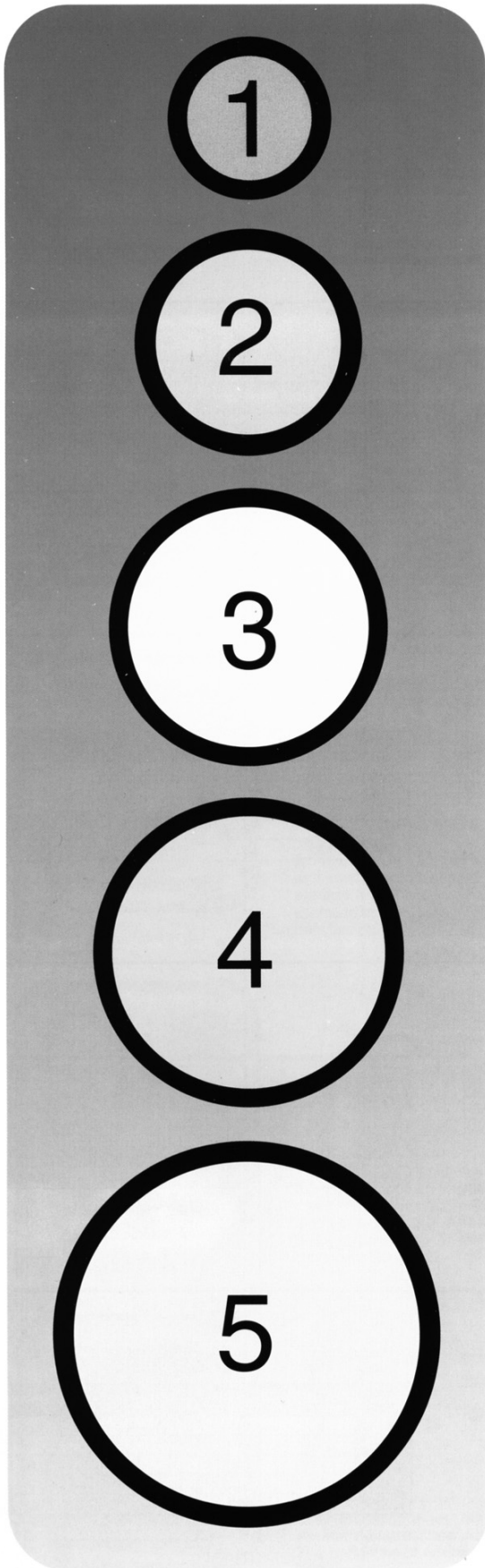

## TUBE SIZES AVAILABLE TO SUIT PIPECLAMP FITTINGS

| PIPECLAMP SIZE | Tube dia (mm) O/D | Tube dia (in.) O/D              | Nominal bore (mm) | Nominal bore (in.)            |
|----------------|-------------------|---------------------------------|-------------------|-------------------------------|
| 1              | 26.9              | 1 <sup>1</sup> / <sub>16</sub>  | 20                | <sup>3</sup> / <sub>4</sub>   |
| 2              | 33.7              | 1 <sup>11</sup> / <sub>32</sub> | 25                | 1                             |
| 3              | 42.4              | 1 <sup>11</sup> / <sub>16</sub> | 32                | 1 <sup>1</sup> / <sub>4</sub> |
| 4              | 48.3              | 1 <sup>29</sup> / <sub>32</sub> | 40                | 1 <sup>1</sup> / <sub>2</sub> |
| 5              | 60.3              | 2 <sup>3</sup> / <sub>8</sub>   | 50                | 2                             |

### NOTE:

The Nominal bore is a discretionary dimension only. The wall thickness can vary depending on the gauge of tube used which will alter the bore dimension.

## TÜV Approval



Europe's leading independent testing house, TÜV, has tested and approved the following range of Pipeclamp Fittings in sizes 1 to 5.

**101, 104, 116, 119, 125, 128, 129, 131, 132, 134, 135, 143, 144, 146, 147, 148, 149, 158, 161, 165, 167M, 168M, 169M, 173M, 173F, 176, 179, 201, 204, 219, 225, 232.**

The technical details in this brochure have not been part of the TÜV testing process.

A copy of the TÜV certificate is available upon request.

## BSI Approval



RS 00344



RS 00344

# PIPECLAMPS

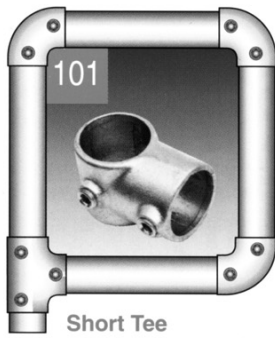

Short Tee

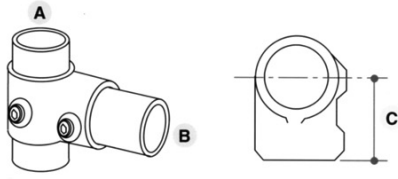

A 90° tee connection between two tubes. Typical use is on straight and level guardrail to connect the vertical to the top rail or end/mid rail to the vertical. This Pipeclamp fitting cannot be used to join tubes in the top of the short tee. For this the Pipeclamp fitting 104 Long Tee should be used.

| PIPECLAMP REF No. | A | B | C  | D | E | F | G | HOLE DIA MM | WEIGHT KGS |
|-------------------|---|---|----|---|---|---|---|-------------|------------|
| 101-1             | 1 | 1 | 42 |   |   |   |   |             | 0.23       |
| 101-2             | 2 | 2 | 46 |   |   |   |   |             | 0.29       |
| 101-3             | 3 | 3 | 60 |   |   |   |   |             | 0.45       |
| 101-3/2           | 3 | 2 | 57 |   |   |   |   |             | 0.43       |
| 101-4             | 4 | 4 | 68 |   |   |   |   |             | 0.62       |
| 101-4/3           | 4 | 3 | 64 |   |   |   |   |             | 0.51       |
| 101-5             | 5 | 5 | 85 |   |   |   |   |             | 0.97       |
| 101-5/4           | 5 | 4 | 74 |   |   |   |   |             | 0.65       |



Long Tee

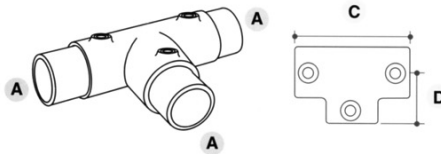

A 90° tee connection between 2 tubes. Typical use is on straight and level guardrail to connect the vertical to the top rail. This Pipeclamp fitting can be used to join tubes in the top of the twin grubscrew long tee.

| PIPECLAMP REF No. | A | B | C   | D  | E | F | G | HOLE DIA MM | WEIGHT KGS |
|-------------------|---|---|-----|----|---|---|---|-------------|------------|
| 104-1             | 1 |   | 84  | 42 |   |   |   |             | 0.38       |
| 104-2             | 2 |   | 92  | 46 |   |   |   |             | 0.50       |
| 104-3             | 3 |   | 120 | 60 |   |   |   |             | 0.86       |
| 104-4             | 4 |   | 136 | 68 |   |   |   |             | 1.10       |
| 104-5             | 5 |   | 170 | 85 |   |   |   |             | 1.75       |



3 Way Through

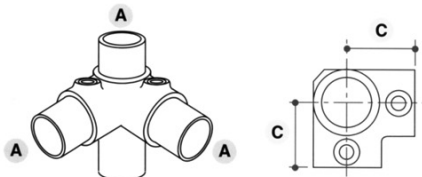

A 90° corner joint with the vertical passing through the Pipeclamp fitting. Typical use is on straight and level guardrail for connecting the mid/lower rail to the vertical at a 90° corner. Can also be used in a similar way on other rectangular structures.

| PIPECLAMP REF No. | A | B | C  | D | E | F | G | HOLE DIA MM | WEIGHT KGS |
|-------------------|---|---|----|---|---|---|---|-------------|------------|
| 116-1             | 1 |   | 42 |   |   |   |   |             | 0.28       |
| 116-2             | 2 |   | 46 |   |   |   |   |             | 0.41       |
| 116-3             | 3 |   | 60 |   |   |   |   |             | 0.70       |
| 116-4             | 4 |   | 68 |   |   |   |   |             | 0.85       |
| 116-5             | 5 |   | 85 |   |   |   |   |             | 1.38       |



2 Socket Cross

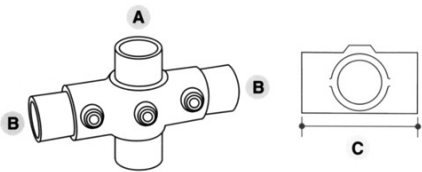

A 90° joint between a vertical and two horizontals. Typical use on straight and level guardrail to connect the mid/lower rails to the upright. The vertical must remain continuous with cross rails cut. Normally used in conjunction with the Pipeclamp fitting 104 Long Tee.

| PIPECLAMP REF No. | A | B | C   | D | E | F | G | HOLE DIA MM | WEIGHT KGS |
|-------------------|---|---|-----|---|---|---|---|-------------|------------|
| 119-1             | 1 | 1 | 84  |   |   |   |   |             | 0.28       |
| 119-2             | 2 | 2 | 92  |   |   |   |   |             | 0.40       |
| 119-3             | 3 | 3 | 120 |   |   |   |   |             | 0.65       |
| 119-4             | 4 | 4 | 136 |   |   |   |   |             | 0.86       |
| 119-5             | 5 | 5 | 170 |   |   |   |   |             | 1.47       |



90° 2 Way Elbow

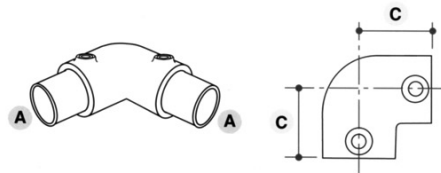

A 90° elbow. Typical use is to connect the end vertical to the top rail in straight and level guardrail. Can also be used to create a 90° tube bend.

| PIPECLAMP REF No. | A | B | C  | D | E | F | G | HOLE DIA MM | WEIGHT KGS |
|-------------------|---|---|----|---|---|---|---|-------------|------------|
| 125-1             | 1 |   | 42 |   |   |   |   |             | 0.27       |
| 125-2             | 2 |   | 46 |   |   |   |   |             | 0.38       |
| 125-3             | 3 |   | 60 |   |   |   |   |             | 0.68       |
| 125-4             | 4 |   | 68 |   |   |   |   |             | 0.77       |
| 125-5             | 5 |   | 85 |   |   |   |   |             | 1.29       |

# PIPECLAMPS



Angle Cross up to 45°

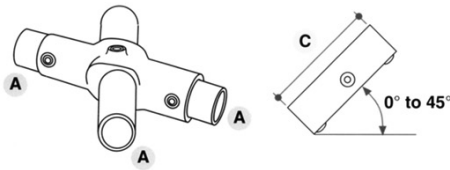

A cross connection supplied machined out to the specific angle between 0° and 45°. The fittings are stored as blanks and machined as required. Typical use on sloping guardrail for the mid/lower rails with the upright vertical. The vertical must remain continuous with the cross rails cut. Used in conjunction with Pipeclamp fitting 127.

| PIPECLAMP REF No. | A | B | C   | D | E | F | G | HOLE DIA MM | WEIGHT KGS |
|-------------------|---|---|-----|---|---|---|---|-------------|------------|
| 126-2             | 2 |   | 160 |   |   |   |   |             | 0.82       |
| 126-3             | 3 |   | 190 |   |   |   |   |             | 1.24       |
| 126-4             | 4 |   | 220 |   |   |   |   |             | 1.50       |

Weights are for blank fittings.



Angle Tee up to 45°

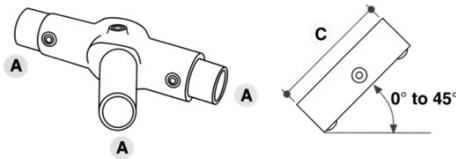

A tee connection supplied machined out to the specific angle between 0° and 45°. The fittings are stored as blanks and machined as required. Typical use on sloping guardrail for the top rails with the upright vertical. Normally used in conjunction with the Pipeclamp fitting 126.

| PIPECLAMP REF No. | A | B | C   | D | E | F | G | HOLE DIA MM | WEIGHT KGS |
|-------------------|---|---|-----|---|---|---|---|-------------|------------|
| 127-2             | 2 |   | 160 |   |   |   |   |             | 0.82       |
| 127-3             | 3 |   | 190 |   |   |   |   |             | 1.24       |
| 127-4             | 4 |   | 220 |   |   |   |   |             | 1.50       |

Weights are for blank fittings.



3 Way 90° Elbow

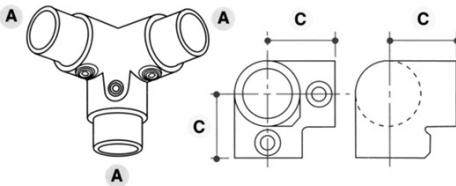

A 3 way enclosed 90° corner joint. Typical use is on straight and level guardrail at a 90° corner where an upright is in position. This Pipeclamp fitting can also be used to create enclosed corner joints in other square structures such as benches etc.

| PIPECLAMP REF No. | A | B | C  | D | E | F | G | HOLE DIA MM | WEIGHT KGS |
|-------------------|---|---|----|---|---|---|---|-------------|------------|
| 128-1             | 1 |   | 42 |   |   |   |   |             | 0.38       |
| 128-2             | 2 |   | 46 |   |   |   |   |             | 0.48       |
| 128-3             | 3 |   | 60 |   |   |   |   |             | 0.82       |
| 128-4             | 4 |   | 68 |   |   |   |   |             | 1.14       |

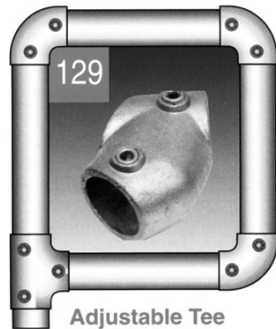

Adjustable Tee

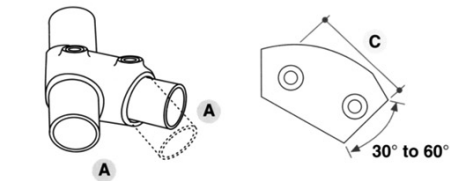

Freely adjustable tee between 30° and 60°. Typical use is a tee connection on angled top rails on steeper slopes or stairs with the upright remaining vertical. This fitting can also be used for bracing on structures. This fitting has no ability to join tubes. An alternative for this situation is the Pipeclamp fitting 127.

| PIPECLAMP REF No. | A | B | C   | D | E | F | G | HOLE DIA MM | WEIGHT KGS |
|-------------------|---|---|-----|---|---|---|---|-------------|------------|
| 129-2             | 2 |   | 86  |   |   |   |   |             | 0.44       |
| 129-3             | 3 |   | 90  |   |   |   |   |             | 0.64       |
| 129-4             | 4 |   | 105 |   |   |   |   |             | 0.97       |



Adjustable Cross

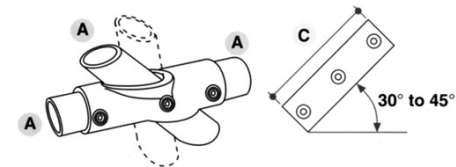

Freely adjustable cross between 30° and 45°. Typical use is as a cross connection on angled mid/lower rails on steeper slopes or stairs with the upright remaining vertical. The upright must remain continuous with the cross rails being cut. Not recommended for use on the top of the vertical.

| PIPECLAMP REF No. | A | B | C   | D | E | F | G | HOLE DIA MM | WEIGHT KGS |
|-------------------|---|---|-----|---|---|---|---|-------------|------------|
| 130-2             | 2 |   | 146 |   |   |   |   |             | 0.82       |
| 130-3             | 3 |   | 180 |   |   |   |   |             | 1.17       |
| 130-4             | 4 |   | 216 |   |   |   |   |             | 1.50       |

# PIPECLAMPS



Wall Plate

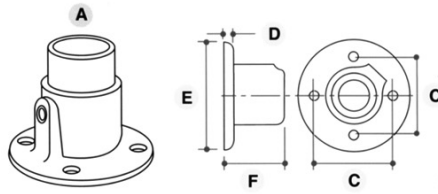

With 4 countersunk holes, this fitting is ideal as a flange to terminate handrail to a wall or other similar application. This fitting may be used on structures where it is only required as a positional fixing.

| PIPECLAMP REF No. | A | B | C  | D | E   | F  | G | HOLE DIA MM | WEIGHT KGS |
|-------------------|---|---|----|---|-----|----|---|-------------|------------|
| 131-1             | 1 |   | 57 | 6 | 80  | 40 |   | 7           | 0.34       |
| 131-2             | 2 |   | 65 | 7 | 90  | 48 |   | 7           | 0.51       |
| 131-3             | 3 |   | 76 | 7 | 102 | 51 |   | 7           | 0.63       |
| 131-4             | 4 |   | 95 | 7 | 115 | 60 |   | 8           | 0.68       |
| 131-5             | 5 |   | 95 | 7 | 127 | 63 |   | 8           | 1.60       |

**WARNING:**  
THIS FITTING IS NOT RECOMMENDED FOR USE AS A BASE PLATE FOR GUARDRAILING



Base Plate

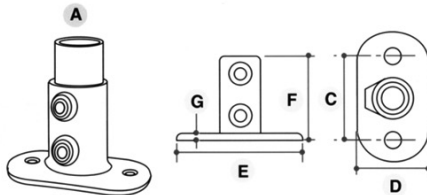

A structural base plate for all aspects of vertical post support. This fitting when used as a base plate for guardrailling should always be positioned with the holes across the line of the guardrail to give maximum strength. The holes in the base plate are large enough to enable the use of mechanical or chemical anchor fixings.

| PIPECLAMP REF No. | A | B | C   | D   | E   | F  | G  | HOLE DIA MM | WEIGHT KGS |
|-------------------|---|---|-----|-----|-----|----|----|-------------|------------|
| 132-1             | 1 |   | 76  | 64  | 114 | 76 | 7  | 11          | 0.50       |
| 132-2             | 2 |   | 90  | 76  | 130 | 90 | 7  | 14          | 0.74       |
| 132-3             | 3 |   | 100 | 80  | 140 | 90 | 7  | 14          | 1.06       |
| 132-4             | 4 |   | 114 | 90  | 150 | 90 | 10 | 14          | 1.38       |
| 132-5             | 5 |   | 127 | 100 | 165 | 90 | 10 | 17          | 1.77       |



Plastic Stop End



PLASTIC PLUG

A plastic stop end for use in the end of tubes. This stop end can be used in either medium or heavy gauge tube. This is only a friction fit and for a more permanent fix an adhesive is recommended.

| PIPECLAMP REF No. | A | B | C | D | E | F | G | HOLE DIA MM | WEIGHT KGS |
|-------------------|---|---|---|---|---|---|---|-------------|------------|
| 133-1             | 1 |   |   |   |   |   |   |             | 0.01       |
| 133-2             | 2 |   |   |   |   |   |   |             | 0.01       |
| 133-3             | 3 |   |   |   |   |   |   |             | 0.01       |
| 133-4             | 4 |   |   |   |   |   |   |             | 0.015      |
| 133-5             | 5 |   |   |   |   |   |   |             | 0.02       |



Ground Socket

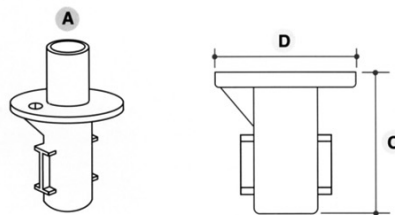

A ground socket cast into concrete which is flush to the finished ground level. The upright is held in place using the grubscrew but can easily be removed without leaving any obstructions.

| PIPECLAMP REF No. | A | B | C   | D   | E | F | G | HOLE DIA MM | WEIGHT KGS |
|-------------------|---|---|-----|-----|---|---|---|-------------|------------|
| 134-2             | 2 |   | 123 | 127 |   |   |   |             | 2.33       |
| 134-3             | 3 |   | 136 | 140 |   |   |   |             | 2.52       |
| 134-4             | 4 |   | 136 | 140 |   |   |   |             | 2.26       |

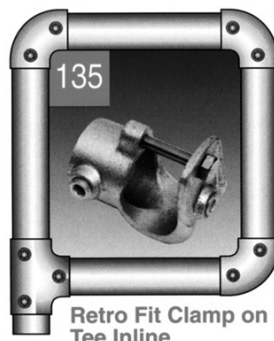

Retro Fit Clamp on Tee Inline

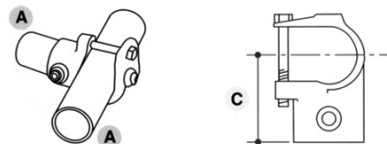

Inline Add on Tee. Used for making additions to, upgrading or modifying an existing structure without having the need to dismantle part or all of that structure.

| PIPECLAMP REF No. | A | B | C  | D | E | F | G | HOLE DIA MM | WEIGHT KGS |
|-------------------|---|---|----|---|---|---|---|-------------|------------|
| 135-1             | 1 |   | 50 |   |   |   |   |             | 0.30       |
| 135-2             | 2 |   | 52 |   |   |   |   |             | 0.33       |
| 135-3             | 3 |   | 68 |   |   |   |   |             | 0.59       |
| 135-4             | 4 |   | 73 |   |   |   |   |             | 0.61       |
| 135-5             | 5 |   | 90 |   |   |   |   |             | 0.92       |

# PIPECLAMPS



Gate Eye

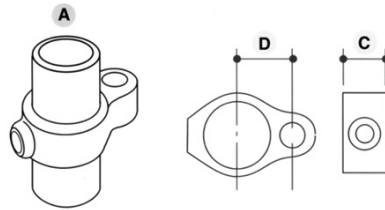

Female section of a 2 part gate hinge.  
Used in conjunction with Pipeclamp fitting reference 140.

| PIPECLAMP REF. NO. | A | B | C  | D  | E | F | G | HOLE DIA MM | WEIGHT KGS |
|--------------------|---|---|----|----|---|---|---|-------------|------------|
| 138-1              | 1 |   | 26 | 30 |   |   |   | 14          | 0.22       |
| 138-2              | 2 |   | 26 | 33 |   |   |   | 14          | 0.26       |
| 138-3              | 3 |   | 26 | 38 |   |   |   | 14          | 0.27       |
| 138-4              | 4 |   | 26 | 41 |   |   |   | 14          | 0.29       |



Gate Hinge

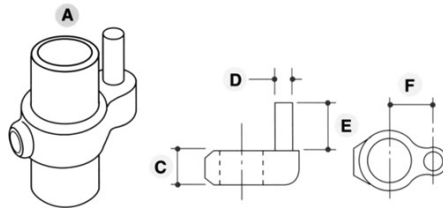

Male section of a 2 part gate hinge.  
Used in conjunction with Pipeclamp fitting reference 138.

| PIPECLAMP REF. NO. | A | B | C  | D  | E  | F  | G | HOLE DIA MM | WEIGHT KGS |
|--------------------|---|---|----|----|----|----|---|-------------|------------|
| 140-1              | 1 |   | 26 | 13 | 38 | 30 |   |             | 0.20       |
| 140-2              | 2 |   | 26 | 13 | 38 | 33 |   |             | 0.25       |
| 140-3              | 3 |   | 26 | 13 | 38 | 38 |   |             | 0.30       |
| 140-4              | 4 |   | 26 | 13 | 38 | 41 |   |             | 0.31       |



Wall Mounted Handrail Bracket

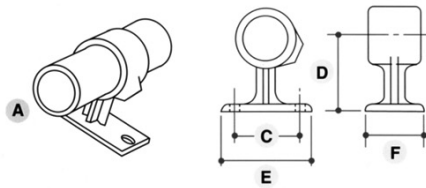

Wall mounting bracket for handrails. Can also be used to tie back structures to wall or to hold kicking plates on a guardrail. This fitting has countersunk holes and is not recommended as a structural fixing. This fitting has no ability to join tubes.

| PIPECLAMP REF. NO. | A | B | C  | D  | E   | F  | G | HOLE DIA MM | WEIGHT KGS |
|--------------------|---|---|----|----|-----|----|---|-------------|------------|
| 143-1              | 1 |   | 57 | 55 | 78  | 45 |   | 8           | 0.36       |
| 143-2              | 2 |   | 62 | 58 | 82  | 45 |   | 8           | 0.45       |
| 143-3              | 3 |   | 78 | 64 | 102 | 45 |   | 8           | 0.57       |
| 143-4              | 4 |   | 82 | 70 | 108 | 50 |   | 8           | 0.78       |

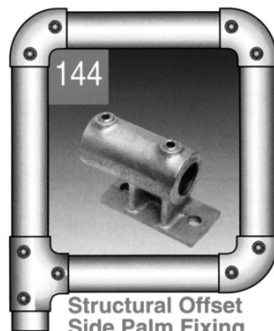

Structural Offset Side Palm Fixing

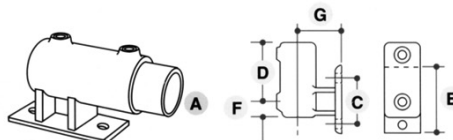

Structural offset side palm base fixing for fixing guardrailing to walls, steps, ramps, etc. The tube is unable to pass through this fitting as supplied, should this be required then the base must be reamed out. Access to the top fixing is restricted. It is recommended that a threaded stud is fixed first with a maximum projection of 25mm.

| PIPECLAMP REF. NO. | A | B | C  | D  | E   | F  | G  | HOLE DIA MM | WEIGHT KGS |
|--------------------|---|---|----|----|-----|----|----|-------------|------------|
| 144-2              | 2 |   | 70 | 75 | 100 | 30 | 60 | 14          | 0.78       |
| 144-3              | 3 |   | 80 | 85 | 110 | 30 | 65 | 14          | 1.12       |
| 144-4              | 4 |   | 90 | 90 | 125 | 30 | 70 | 14          | 1.55       |

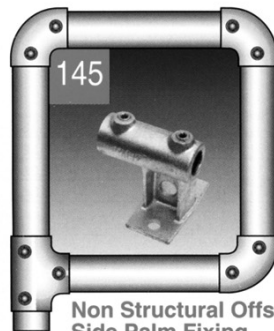

Non Structural Offset Side Palm Fixing

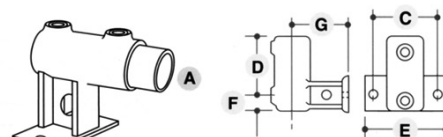

This fitting is designed for palm fixing guardrailing and balustrading to walls, parapets, steps and ramps.

| PIPECLAMP REF. NO. | A | B | C  | D  | E   | F  | G  | HOLE DIA MM | WEIGHT KGS |
|--------------------|---|---|----|----|-----|----|----|-------------|------------|
| 145-2              | 2 |   | 70 | 75 | 100 | 30 | 60 | 14          | 0.77       |

# PIPECLAMPS



**Structural Flush Side Palm Fixing**

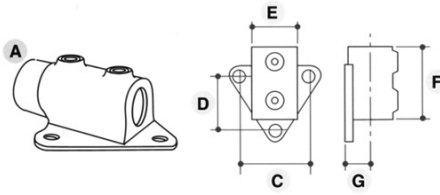

Structural flush side palm base fixing for fixing guardrailing to wall steps or ramps etc. The flush design enables posts to be tight to the structure. The tube is unable to pass through the fitting. Should this be required then the base must be reamed out. If the base is reamed out the bottom fixing will become redundant.

| PIPECLAMP REF. NO. | A | B | C  | D  | E  | F  | G  | HOLE DIA MM | WEIGHT KGS |
|--------------------|---|---|----|----|----|----|----|-------------|------------|
| 146-2              | 2 |   | 78 | 68 | 45 | 76 | 25 | 11          | 0.63       |
| 146-3              | 3 |   | 83 | 72 | 56 | 85 | 28 | 11          | 0.81       |
| 146-4              | 4 |   | 86 | 78 | 61 | 89 | 31 | 11          | 0.96       |



**Offset Swivel Tee**

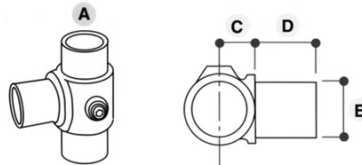

An internal swivel tee used in conjunction with other Pipeclamp fittings in the range to create a 360° swivel joint. Ideal use on handrail or offset guardrailing down variable angled slopes. Eliminates the requirement for specialised angle fittings.

| PIPECLAMP REF. NO. | A | B | C  | D  | E  | F | G | HOLE DIA MM | WEIGHT KGS |
|--------------------|---|---|----|----|----|---|---|-------------|------------|
| 147-2              | 2 |   | 22 | 28 | 34 |   |   |             | 0.36       |
| 147-3              | 3 |   | 28 | 35 | 42 |   |   |             | 0.55       |
| 147-4              | 4 |   | 31 | 42 | 48 |   |   |             | 0.65       |



**Short Swivel Inline Tee**

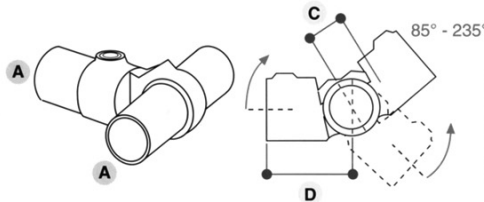

Shown, priced and sold as a single fitting but normally used in pairs to create angles between 85° and 235°. A central tube is required to join the fittings together to create the angle. When working out the correct tube length dimension 'C' should be subtracted.

| PIPECLAMP REF. NO. | A | B | C   | D  | E | F | G | HOLE DIA MM | WEIGHT KGS |
|--------------------|---|---|-----|----|---|---|---|-------------|------------|
| 148-1              | 1 |   | -31 | 55 |   |   |   |             | 0.20       |
| 148-2              | 2 |   | -33 | 60 |   |   |   |             | 0.30       |
| 148-3              | 3 |   | -40 | 75 |   |   |   |             | 0.42       |
| 148-4              | 4 |   | -55 | 90 |   |   |   |             | 0.54       |

**Note:**

When using Pipeclamp 148 fittings for the top rail of a guardrail, the top of the upright must NOT be reduced in length but left at full height. The top of the tube will need to be capped using a Pipeclamp 133.



**Inline External Tube Connector**

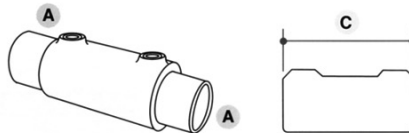

An inline external tube connector for joining two tubes of the same diameter. This fitting is not recommended to be used in high load applications. For a smooth inline joint the Pipeclamp fitting 150 can be used.

| PIPECLAMP REF. NO. | A | B | C   | D | E | F | G | HOLE DIA MM | WEIGHT KGS |
|--------------------|---|---|-----|---|---|---|---|-------------|------------|
| 149-1              | 1 |   | 76  |   |   |   |   |             | 0.27       |
| 149-2              | 2 |   | 88  |   |   |   |   |             | 0.40       |
| 149-3              | 3 |   | 100 |   |   |   |   |             | 0.52       |
| 149-4              | 4 |   | 100 |   |   |   |   |             | 0.64       |
| 149-5              | 5 |   | 120 |   |   |   |   |             | 1.09       |

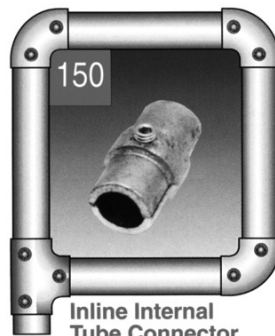

**Inline Internal Tube Connector**

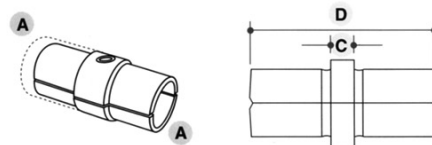

An inline internal tube connector for joining two tubes of the same diameter. This fitting can only be used with 3.2mm wall thick tube. This fitting is not recommended for high or tensile load applications.

| Pipeclamp REF. No. | A | B | C  | D  | E | F | G | HOLE DIA MM | WEIGHT KGS |
|--------------------|---|---|----|----|---|---|---|-------------|------------|
| 150-2              | 2 |   | 20 | 80 |   |   |   |             | 0.26       |
| 150-3              | 3 |   | 20 | 80 |   |   |   |             | 0.38       |
| 150-4              | 4 |   | 20 | 80 |   |   |   |             | 0.55       |

# PIPECLAMPS

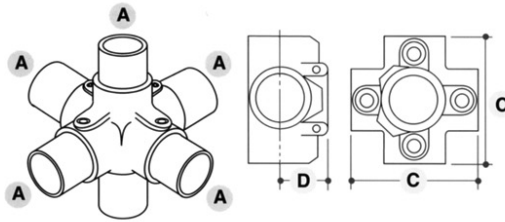

A 4 way cross that enables the vertical to pass through the centre of the fitting with the 4 horizontal tubes joining at 90° to each other. Ideal for structures with multiple verticals. The vertical must remain continuous with the cross rails being cut.

| PIPECLAMP REF. NO. | A | B | C   | D  | E | F | G | HOLE DIA. MM | WEIGHT |
|--------------------|---|---|-----|----|---|---|---|--------------|--------|
| 158-1              | 1 |   | 82  | 32 |   |   |   |              | 0.     |
| 158-2              | 2 |   | 92  | 37 |   |   |   |              | 0.     |
| 158-3              | 3 |   | 120 | 40 |   |   |   |              | 1.     |
| 158-4              | 4 |   | 136 | 53 |   |   |   |              | 1.     |
| 158-5              | 5 |   | 168 | 62 |   |   |   |              | 2.     |

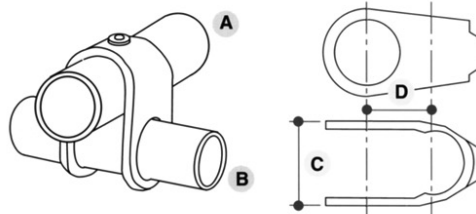

Offset add on tee. Used for making additions to, upgrading or modifying an existing structure without having the need to dismantle part or all of that structure.

| PIPECLAMP REF. NO. | A | B | C  | D  | E | F | G | HOLE DIA. MM | WEIGHT |
|--------------------|---|---|----|----|---|---|---|--------------|--------|
| 160-1              | 1 | 1 | 40 | 27 |   |   |   |              | 0.     |
| 160-2              | 2 | 2 | 48 | 34 |   |   |   |              | 0.     |
| 160-3              | 3 | 3 | 58 | 43 |   |   |   |              | 0.     |
| 160-4              | 4 | 4 | 63 | 48 |   |   |   |              | 0.     |
| 160-5              | 5 | 5 | 75 | 62 |   |   |   |              | 0.     |

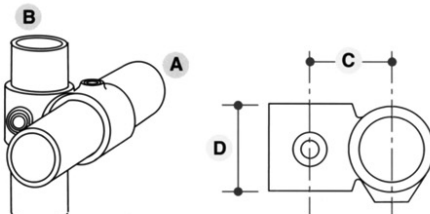

A 90° offset crossover fitting. The tube is unable to be jointed within this fitting. Ideal applications are for racking systems or offset guardrail. Where dimension 'D' indicates two figures, the first figure refers to tube 'A', the second refers to tube 'B'.

| PIPECLAMP REF. NO. | A | B | C  | D     | E | F | G | HOLE DIA. MM | WEIGHT |
|--------------------|---|---|----|-------|---|---|---|--------------|--------|
| 161-1              | 1 | 1 | 34 | 34    |   |   |   |              | 0      |
| 161-2              | 2 | 2 | 40 | 38    |   |   |   |              | 0      |
| 161-3              | 3 | 3 | 49 | 47    |   |   |   |              | 0      |
| 161-3/2            | 3 | 2 | 45 | 40/46 |   |   |   |              | 0      |
| 161-4              | 4 | 4 | 55 | 51    |   |   |   |              | 0      |
| 161-4/2            | 4 | 2 | 48 | 40/51 |   |   |   |              | 0      |
| 161-5              | 5 | 5 | 67 | 61    |   |   |   |              | 0      |

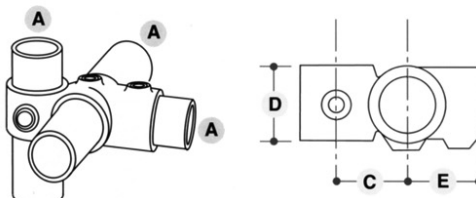

A combination fitting designed for use in the construction of racking systems. The fitting enables the connection of a vertical upright at 90° to 2 horizontal rails, 1 being the tie rail, the other being the load rail. On pallet racking the upright normally has the load rail on the inside, whilst for shelved racking the upright normally has the load rail on the outside.

| PIPECLAMP REF. NO. | A | B | C  | D  | E  | F | G | HOLE DIA. MM | WEIGHT |
|--------------------|---|---|----|----|----|---|---|--------------|--------|
| 165-1              | 1 | 1 | 34 | 38 | 42 |   |   |              | 0      |
| 165-2              | 2 | 2 | 40 | 38 | 46 |   |   |              | 0      |
| 165-3              | 3 | 3 | 49 | 46 | 60 |   |   |              | 0      |
| 165-4              | 4 | 4 | 55 | 51 | 68 |   |   |              | 0      |
| 165-5              | 5 | 5 | 67 | 61 | 85 |   |   |              | 1      |



# PIPECLAMPS

## THE SWIVEL RANGE

FITTING REFERENCE NUMBERS: 167M, 168M, 169M, 173M & 173F

The Swivel Range is constructed using the female and male parts. The 173F is common to all combinations. The range can be supplied as parts or complete using either a rivet or nut and bolt to join the male and female fittings. Because the lugs on the fittings sizes 1 to 5 are the same dimension, it is possible to mix sizes if required, ie: A 173F-1 with a 173M-4.

In addition to being used with the 173F to make the combination, all the 'M' fittings can also be used to secure various types of infill in place.

### WARNING:

**AN ENTIRE STRUCTURE SHOULD NOT BE BUILT JUST USING SWIVEL FITTINGS.**



Double Male  
Inline Swivel

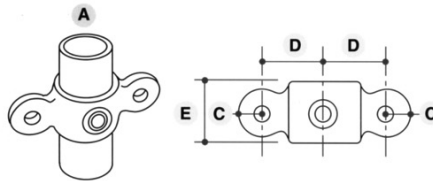

A double male fitting with the lugs at 180° to each other.

| Pipeclamp<br>REF No. | A | B | C  | D  | E  | F | G | HOLE DIA<br>MM | WEIGHT<br>KGS |
|----------------------|---|---|----|----|----|---|---|----------------|---------------|
| 167M-1               | 1 |   | 19 | 40 | 38 |   |   | 10.5           | 0.27          |
| 167M-2               | 2 |   | 19 | 43 | 40 |   |   | 10.5           | 0.38          |
| 167M-3               | 3 |   | 19 | 48 | 46 |   |   | 10.5           | 0.47          |
| 167M-4               | 4 |   | 19 | 54 | 48 |   |   | 10.5           | 0.49          |
| 167M-5               | 5 |   | 19 | 62 | 52 |   |   | 10.5           | 0.72          |



Double Inline Swivel  
Combination

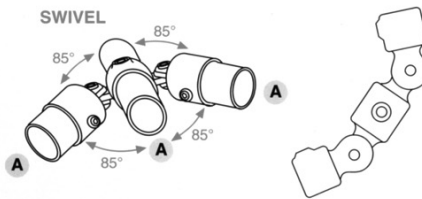

Complete double swivel with the swivel connectors at 180° to each other. Each swivel has a travel of approximately 85° from the horizontal in both vertical directions.

| PIPECLAMP<br>REF No. | A | B | C | D | E | F | G | HOLE DIA<br>MM | WEIGHT<br>KGS |
|----------------------|---|---|---|---|---|---|---|----------------|---------------|
| 167-1                | 1 |   |   |   |   |   |   |                | 0.99          |
| 167-2                | 2 |   |   |   |   |   |   |                | 1.12          |
| 167-3                | 3 |   |   |   |   |   |   |                | 1.36          |
| 167-4                | 4 |   |   |   |   |   |   |                | 1.58          |
| 167-5                | 5 |   |   |   |   |   |   |                | 2.08          |



90 Degree Male  
Corner Swivel

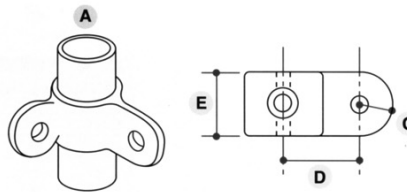

Double male fitting with the 2 lugs at 90° to each other.

| PIPECLAMP<br>REF No. | A | B | C  | D  | E  | F | G | HOLE DIA<br>MM | WEIGHT<br>KGS |
|----------------------|---|---|----|----|----|---|---|----------------|---------------|
| 168M-1               | 1 |   | 19 | 40 | 38 |   |   | 10.5           | 0.37          |
| 168M-2               | 2 |   | 19 | 43 | 40 |   |   | 10.5           | 0.40          |
| 168M-3               | 3 |   | 19 | 48 | 46 |   |   | 10.5           | 0.46          |
| 168M-4               | 4 |   | 19 | 54 | 48 |   |   | 10.5           | 0.47          |



90 Degree  
Corner Swivel

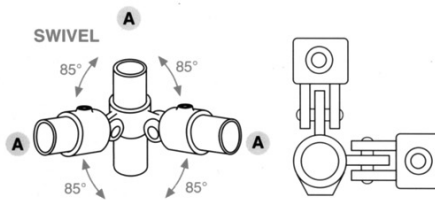

Complete double swivel with the swivel connectors at 90° to each other. Each swivel has a travel of approximately 85° from the horizontal on both vertical directions.

| PIPECLAMP<br>REF No. | A | B | C | D | E | F | G | HOLE DIA<br>MM | WEIGHT<br>KGS |
|----------------------|---|---|---|---|---|---|---|----------------|---------------|
| 168-1                | 1 |   |   |   |   |   |   |                | 0.98          |
| 168-2                | 2 |   |   |   |   |   |   |                | 1.13          |
| 168-3                | 3 |   |   |   |   |   |   |                | 1.35          |
| 168-4                | 4 |   |   |   |   |   |   |                | 1.57          |

# PIPECLAMPS

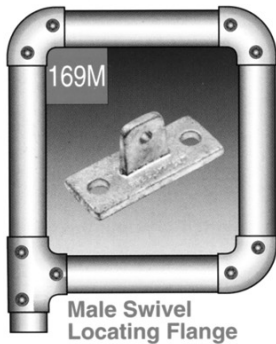

**Male Swivel Locating Flange**

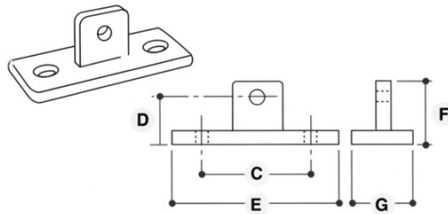

Non structural male locating flange.

| PIPECLAMP REF No. | A | B | C  | D  | E   | F  | G  | HOLE DIA MM | WEIGHT KGS |
|-------------------|---|---|----|----|-----|----|----|-------------|------------|
| 169M              |   |   | 85 | 35 | 120 | 51 | 50 | 11.0        | 0.38       |



**Swivel Locating Flange**

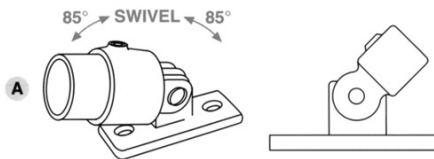

Complete locating swivel. Swivel has a travel of approximately 85° from the vertical in each direction.

| PIPECLAMP REF No. | A | B | C | D | E | F | G | HOLE DIA MM | WEIGHT KGS |
|-------------------|---|---|---|---|---|---|---|-------------|------------|
| 169-1             | 1 |   |   |   |   |   |   |             | 0.71       |
| 169-2             | 2 |   |   |   |   |   |   |             | 0.76       |
| 169-3             | 3 |   |   |   |   |   |   |             | 0.84       |
| 169-4             | 4 |   |   |   |   |   |   |             | 0.95       |
| 169-5             | 5 |   |   |   |   |   |   |             | 1.08       |

**WARNING:**  
THIS IS NOT A STRUCTURAL FITTING AND SHOULD NOT BE USED AS AN ANGLED BASE FLANGE.



**Female Swivel**

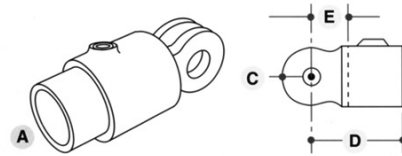

This fitting is designed to be used in conjunction with the "M" fittings and is not generally used on its own. This can be connected to the "M" fitting by either rivet or nut and bolt.

| PIPECLAMP REF No. | A | B | C  | D  | E  | F | G | HOLE DIA MM | WEIGHT KGS |
|-------------------|---|---|----|----|----|---|---|-------------|------------|
| 173F-1            | 1 |   | 19 | 60 | 25 |   |   | 10.5        | 0.28       |
| 173F-2            | 2 |   | 19 | 65 | 25 |   |   | 10.5        | 0.35       |
| 173F-3            | 3 |   | 19 | 68 | 25 |   |   | 10.5        | 0.43       |
| 173F-4            | 4 |   | 19 | 76 | 25 |   |   | 10.5        | 0.52       |
| 173F-5            | 5 |   | 19 | 85 | 32 |   |   | 10.5        | 0.66       |



**Single Male Swivel**

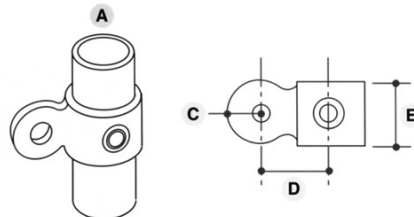

Single male fitting with only 1 lug.

| PIPECLAMP REF No. | A | B | C  | D  | E  | F | G | HOLE DIA MM | WEIGHT KGS |
|-------------------|---|---|----|----|----|---|---|-------------|------------|
| 173M-1            | 1 |   | 19 | 40 | 38 |   |   | 10.5        | 0.25       |
| 173M-2            | 2 |   | 19 | 43 | 40 |   |   | 10.5        | 0.27       |
| 173M-3            | 3 |   | 19 | 48 | 46 |   |   | 10.5        | 0.36       |
| 173M-4            | 4 |   | 19 | 54 | 48 |   |   | 10.5        | 0.45       |
| 173M-5            | 5 |   | 19 | 62 | 52 |   |   | 10.5        | 0.54       |

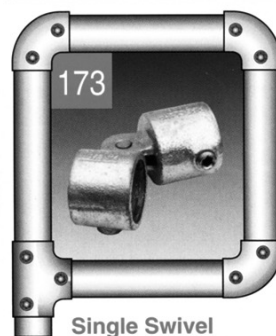

**Single Swivel**

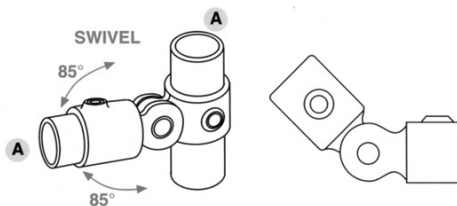

Complete single swivel. The swivel has a travel of approximately 85° from the horizontal in both vertical directions.

| PIPECLAMP REF No. | A | B | C | D | E | F | G | HOLE DIA MM | WEIGHT KGS |
|-------------------|---|---|---|---|---|---|---|-------------|------------|
| 173-1             | 1 |   |   |   |   |   |   |             | 0.57       |
| 173-2             | 2 |   |   |   |   |   |   |             | 0.66       |
| 173-3             | 3 |   |   |   |   |   |   |             | 0.83       |
| 173-4             | 4 |   |   |   |   |   |   |             | 1.01       |
| 173-5             | 5 |   |   |   |   |   |   |             | 1.24       |

# PIPECLAMPS

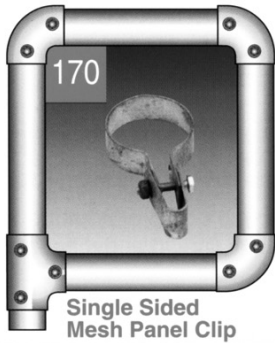

**Single Sided Mesh Panel Clip**

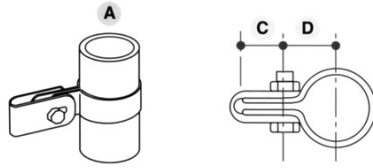

Single location weldmesh panel clip. The slotted design of the panel clip enables adjustment in the location of the mesh panels. Supplied with M6 x 30mm long nut and bolt. This fitting can also be used to locate other materials up to 10mm thick provided the safety saddle is removed.

| PIPECLAMP REF No. | A | B | C  | D  | E | F | G | HOLE DIA MM | WEIGHT KGS |
|-------------------|---|---|----|----|---|---|---|-------------|------------|
| 170-1             | 1 |   | 22 | 25 |   |   |   |             | 0.07       |
| 170-2             | 2 |   | 25 | 28 |   |   |   |             | 0.08       |
| 170-3             | 3 |   | 25 | 33 |   |   |   |             | 0.08       |
| 170-4             | 4 |   | 25 | 35 |   |   |   |             | 0.09       |
| 170-5             | 5 |   | 25 | 40 |   |   |   |             | 0.10       |

Dimension "C" can be increased by up to 7mm because of the slotted hole.

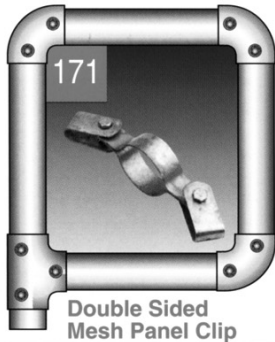

**Double Sided Mesh Panel Clip**

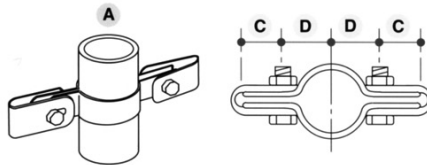

Double location weldmesh panel clip. The slotted design of the panel clip enables adjustment in the location of the mesh panels. Supplied with M6 x 30mm long nut and bolt. This fitting can also be used to locate other materials up to 10mm thick provided the safety saddle is removed.

| PIPECLAMP REF No. | A | B | C  | D  | E | F | G | HOLE DIA MM | WEIGHT KGS |
|-------------------|---|---|----|----|---|---|---|-------------|------------|
| 171-1             | 1 |   | 22 | 25 |   |   |   |             | 0.12       |
| 171-2             | 2 |   | 25 | 28 |   |   |   |             | 0.13       |
| 171-3             | 3 |   | 25 | 33 |   |   |   |             | 0.14       |
| 171-4             | 4 |   | 25 | 35 |   |   |   |             | 0.15       |
| 171-5             | 5 |   | 25 | 40 |   |   |   |             | 0.16       |

Dimension "C" can be increased by up to 7mm because of the slotted hole.



**3 Way Outlet Tee**

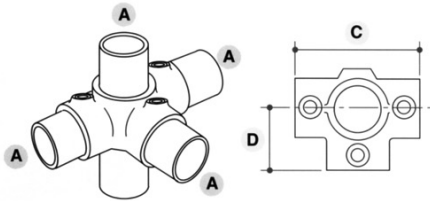

3 way tee used to join 3 tubes at 90° to each other with the vertical passing through the fitting. Typical use would be on structures such as market stall or play frames.

| PIPECLAMP REF No. | A | B | C   | D  | E | F | G | HOLE DIA MM | WEIGHT KGS |
|-------------------|---|---|-----|----|---|---|---|-------------|------------|
| 176-1             | 1 |   | 84  | 42 |   |   |   |             | 0.35       |
| 176-2             | 2 |   | 92  | 46 |   |   |   |             | 0.46       |
| 176-3             | 3 |   | 120 | 60 |   |   |   |             | 0.78       |
| 176-4             | 4 |   | 136 | 69 |   |   |   |             | 1.20       |
| 176-5             | 5 |   | 170 | 85 |   |   |   |             | 1.84       |



**Locking Collar**

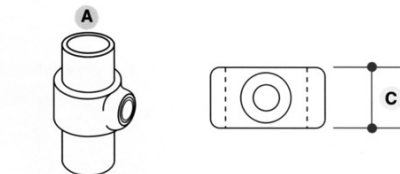

A locking collar used as extra support for a Pipeclamp fitting on structures where the slip load on the grubscrew may be exceeded i.e. racking. Can also be used to support a Pipeclamp fitting that is required to be left undone. i.e. a gate hinge.

| PIPECLAMP REF No. | A | B | C  | D | E | F | G | HOLE DIA MM | WEIGHT KGS |
|-------------------|---|---|----|---|---|---|---|-------------|------------|
| 179-1             | 1 |   | 22 |   |   |   |   |             | 0.15       |
| 179-2             | 2 |   | 26 |   |   |   |   |             | 0.15       |
| 179-3             | 3 |   | 26 |   |   |   |   |             | 0.18       |
| 179-4             | 4 |   | 26 |   |   |   |   |             | 0.21       |
| 179-5             | 5 |   | 26 |   |   |   |   |             | 0.30       |



**Hook**

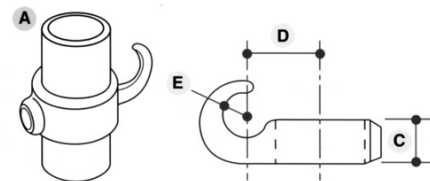

Chain hook. Used to locate chains across openings. Not ideal for permanent chain location. Recommended that one end of the chain is fixed using a Pipeclamp fitting reference 173M and held in place with a nut and bolt.

| PIPECLAMP REF No. | A | B | C  | D  | E  | F | G | HOLE DIA MM | WEIGHT KGS |
|-------------------|---|---|----|----|----|---|---|-------------|------------|
| 182-1             | 1 |   | 26 | 31 | 8  |   |   |             | 0.17       |
| 182-2             | 2 |   | 26 | 35 | 13 |   |   |             | 0.21       |
| 182-3             | 3 |   | 26 | 40 | 13 |   |   |             | 0.23       |
| 182-4             | 4 |   | 26 | 43 | 13 |   |   |             | 0.24       |

Dimension 'E' is the hooks internal radius.

# PIPECLAMPS

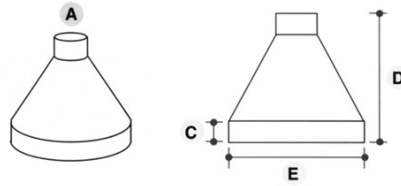

| PIPECLAMP REF No. | A | B  | C   | D   | E | F | G | HOLE DIA MM | WEIGHT KGS |
|-------------------|---|----|-----|-----|---|---|---|-------------|------------|
| 192-2             | 2 | 25 | 125 | 146 |   |   |   |             | 0.35       |
| 192-3             | 3 | 25 | 150 | 157 |   |   |   |             | 0.40       |
| 192-4             | 4 | 25 | 155 | 170 |   |   |   |             | 0.45       |

A weather shield for the Pipeclamp base fixing 132. Used on flat roofs to give additional protection around the base fixing following installation. The weather shield needs to be sealed with a silicone sealant. For installation procedure refer to technical details on page 18.

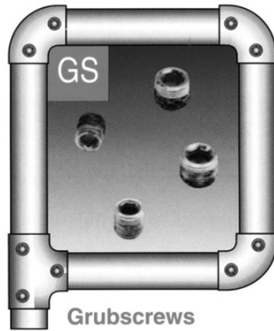

| PIPECLAMP REF No. | A     | B | C       | D | E | F | G | HOLE DIA MM | WEIGHT KGS |
|-------------------|-------|---|---------|---|---|---|---|-------------|------------|
| GS 1-2            | 1-2   |   | 1/4 BSP |   |   |   |   |             |            |
| GS 3-4-5          | 3-4-5 |   | 3/8 BSP |   |   |   |   |             |            |

Electro plated case hardened grubscrews. These grubscrews are supplied pre fitted into the fittings.

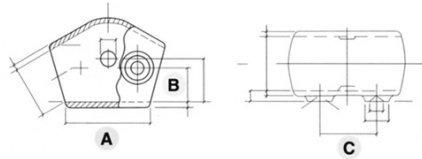

| PIPECLAMP REF No. | A    | B    | C    |
|-------------------|------|------|------|
| 224-2             | 58.0 | 21.0 |      |
| 224-3             | 72.0 | 28.0 | 48.0 |
| 224-4             | 76.0 | 30.0 | 52.0 |

A variable angle in line connector (110° - 180°) Ideally suited for use between the vertical end post and sloping top rail on stair guard railing.

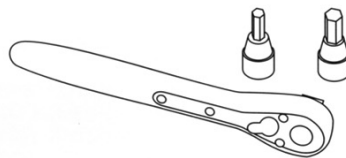

| PIPECLAMP REF No. | A   | B | C | D | E | F | G | HOLE DIA MM | WEIGHT KGS |
|-------------------|-----|---|---|---|---|---|---|-------------|------------|
| 233               | 1-5 |   |   |   |   |   |   |             |            |

Dual sized ratchet key. The ratchet has two removable hexagon socket heads to enable the complete range of Pipeclamp fitting to be tightened. The use of the ratchet enables the grubscrews to be tightened to the correct torque.

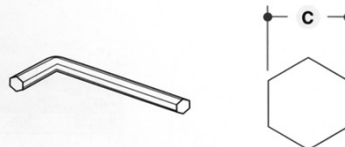

| PIPECLAMP REF No. | A     | B | C                 | D | E | F | G | HOLE DIA MM | WEIGHT KGS |
|-------------------|-------|---|-------------------|---|---|---|---|-------------|------------|
| 235 1-2           | 1-2   |   | 1/4" across flats |   |   |   |   |             |            |
| 235 3-4-5         | 3-4-5 |   | 3/8" across flats |   |   |   |   |             |            |

Hexagonal key. The allen key is the only tool required to tighten up a Pipeclamp fitting. The use of the dual ratchet Pipeclamp reference 233 is recommended to achieve the required torque.

# PIPECLAMPS

## FITTINGS FOR USE ON INVALID RAMPS OR SHALLOW GRADIENTS BETWEEN 4° AND 10°

The following range has been designed to enable a guardrail to be constructed down (up) a slope between 4° and 10° without the need for specially reamed out fittings or bending the tube.



**201**  
Slope Range  
Short Tee

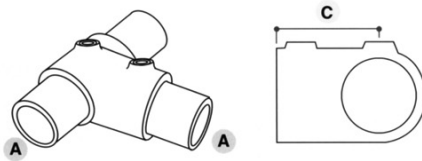

| PIPECLAMP REF No. | A | B | C  | D | E | F | G | HOLE DIA MM | WEIGHT KGS |
|-------------------|---|---|----|---|---|---|---|-------------|------------|
| 201-4             | 4 |   | 70 |   |   |   |   |             | 0.62       |

An adjustable tee connection between two tubes. Used on ramps and shallow gradient guardrail between verticals and top rails or the mid/lower rails to an end vertical. This fitting cannot be used to joint tubes in the short tee. For this the Pipeclamp fitting 204 long tee should be used.



**204**  
Slope Range  
Long Tee

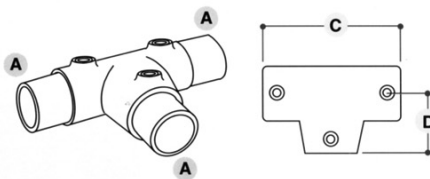

| PIPECLAMP REF No. | A | B | C   | D  | E | F | G | HOLE DIA MM | WEIGHT KGS |
|-------------------|---|---|-----|----|---|---|---|-------------|------------|
| 204-4             | 4 |   | 160 | 70 |   |   |   |             | 1.26       |

An adjustable tee connection between two tubes. Used on ramps and shallow gradient guardrail between verticals and top rails. This fitting can be used to joint tubes in the long tee.



**219**  
Slope Range  
Socket Cross

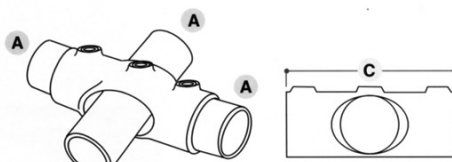

| PIPECLAMP REF No. | A | B | C   | D | E | F | G | HOLE DIA MM | WEIGHT KGS |
|-------------------|---|---|-----|---|---|---|---|-------------|------------|
| 219-4             | 4 |   | 160 |   |   |   |   |             | 0.95       |

An adjustable cross for connecting tubes between mid/lower rails and the vertical on ramps or shallow gradients. The vertical must remain continuous with the cross rails being cut.

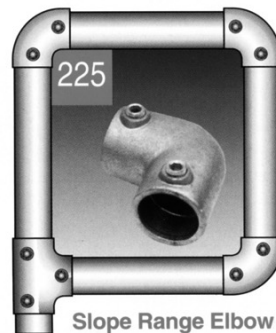

**225**  
Slope Range  
Elbow

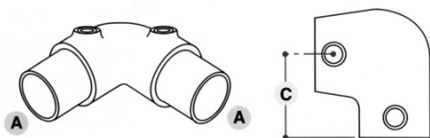

| PIPECLAMP REF No. | A | B | C  | D | E | F | G | HOLE DIA MM | WEIGHT KGS |
|-------------------|---|---|----|---|---|---|---|-------------|------------|
| 225-4             | 4 |   | 70 |   |   |   |   |             | 0.95       |

An adjustable elbow. Used for the connection of the first vertical post at the start of the incline to the top rail. Only one barrel has the ability to take the adjustability, the other is fixed.

# PIPECLAMPS



Slope Range Base

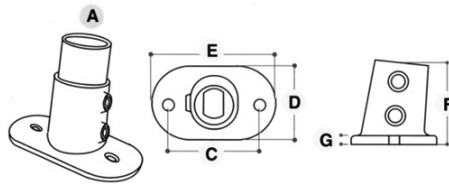

| PIPECLAMP REF No. | A | B | C   | D  | E   | F  | G | HOLE DIA MM | WEIGHT KGS |
|-------------------|---|---|-----|----|-----|----|---|-------------|------------|
| 232-4             | 4 |   | 114 | 90 | 150 | 90 | 7 | 14          | 1.25       |

An adjustable structural base fitting for the vertical. The design of this fitting will only allow it to be installed in the correct plane. For correct orientation see details below.

## FITTINGS DESIGNED TO ENABLE CONSTRUCTION TO MEET THE REQUIREMENTS OF BS6180.

### To achieve a loading of 0.74 kN/m

Dimension A = 1830mm max when using 48.3mm od Grade 50C tube with a 5mm wall thickness for the upright.  
 Dimension A = 830mm max when using BS1387 48.3mm od tube with a 3.2mm wall thickness for the upright.  
 All the cross rails can be BS 1387 48.3 od tube with a 3.2mm wall.

Height B = 1100mm from finished floor level to  $\phi$  of the top rail.

A maximum gap of 100mm, Dim C, can be achieved by placing the bottom rail on the 232 base fitting and a suitable infill panel installed.

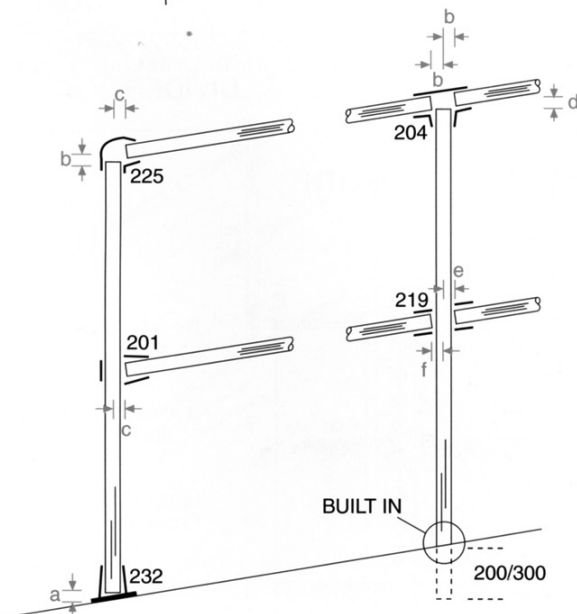
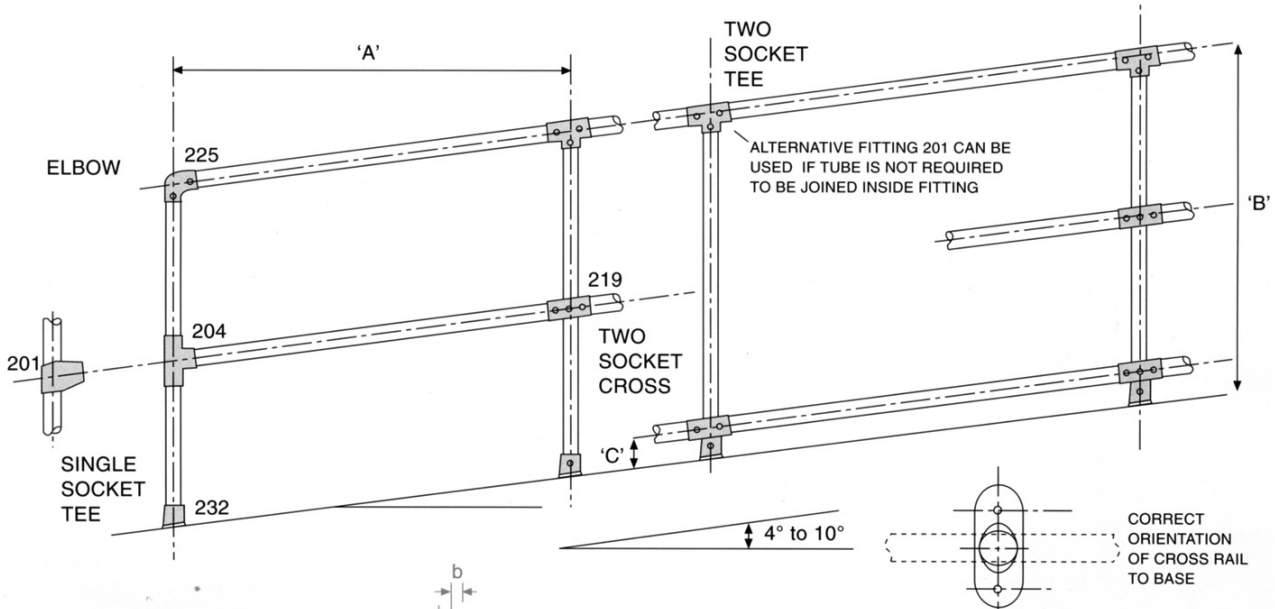

## HOW TO CALCULATE CORRECT TUBE LENGTH.

### Upright

To calculate the upright height select the top post fitting to be used (201, 204, 225). Dim 'd' is the same for the 201 and 204 fitting. Subtract the relevant dimension from the upright length then either add or subtract the dimension for the ground fitting being used.

### Cutting Chart

|   |    |
|---|----|
| a | 7  |
| b | 25 |
| c | 28 |
| d | 28 |
| e | 28 |
| f | 28 |

### Crossrail

To calculate the crossrail length select the fittings being used then subtract the relevant dimension from the upright centres measured on the slope.

# PIPECLAMPS

## UPRIGHT CONSTRUCTION FOR INLINE GUARDRAIL ON LEVEL GROUND.

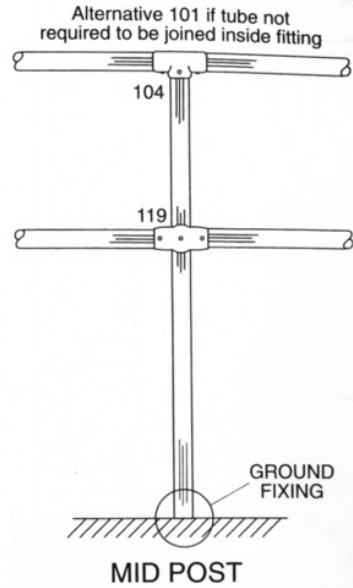
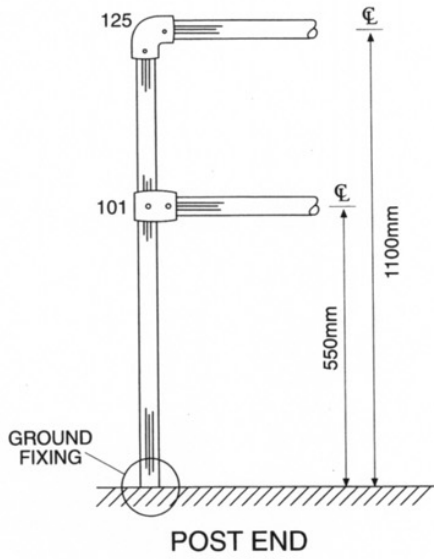

For details on ground fixing cutting sizes refer to page 18.

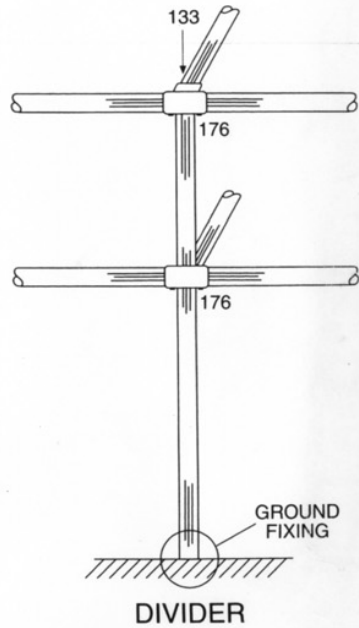
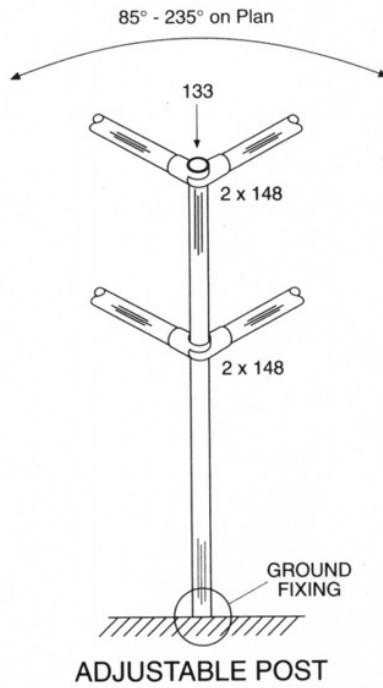
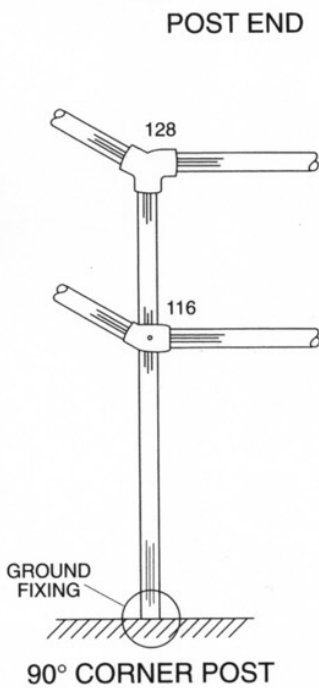

## HOW TO CALCULATE CORRECT TUBE LENGTH

|   | c   |
|---|-----|
| 1 | -14 |
| 2 | -17 |
| 3 | -22 |
| 4 | -25 |
| 5 | -30 |

This applies to Pipeclamp fittings: 101, 104, 116, 119, 125, 128, 135, 158, 176, when calculating the cutting lengths of the upright and crossrails to avoid tube interference.

For Pipeclamp fitting 148 refer to fitting details for the cutting sizes.

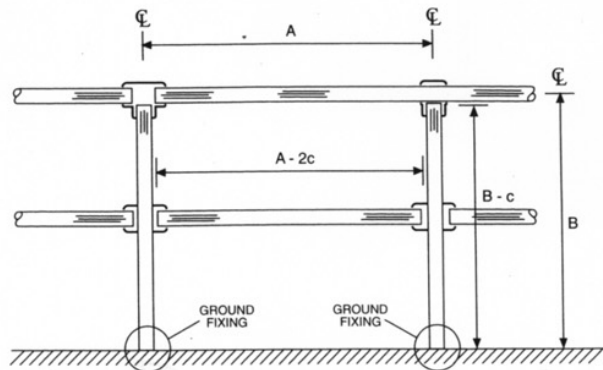

A = Distance between uprights centre to centre

B = Height of upright ground level to  $\text{€}$  top rail

Upright height =  $B - c$   
Cross rail =  $A - 2c$

# PIPECLAMPS

## UPRIGHT CONSTRUCTION FOR INLINE GUARDRAIL ON A SLOPE

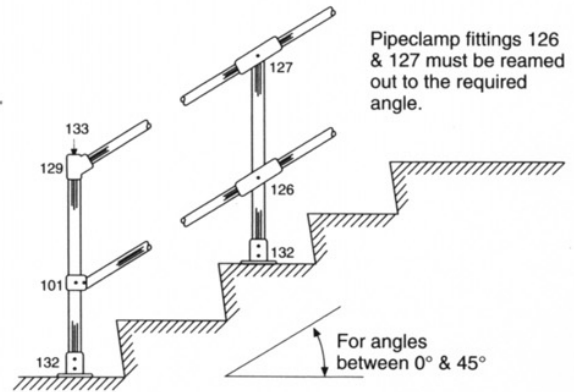
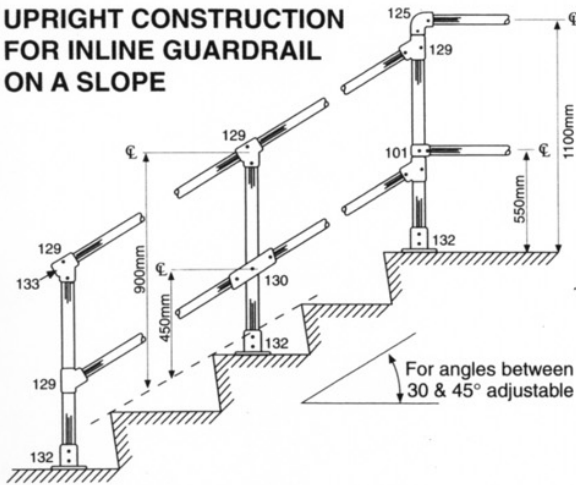

Note: Between 30° and 45° 129 fitting may be used to terminate handrails, between 10° & 30° 101 fitting with tube bent to suit may be used, between 0° & 10° type 201 fitting may be used.

## HOW TO CALCULATE CORRECT TUBE LENGTH - UPRIGHTS

### Using fittings 126 & 127

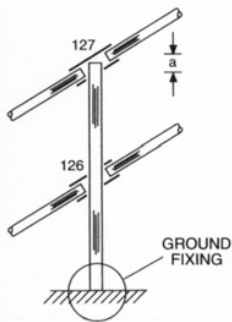

DIMENSION 'a'

|    | 2  | 3  | 4  |
|----|----|----|----|
| 0  | 19 | 22 | 25 |
| 5  | 16 | 19 | 22 |
| 10 | 16 | 16 | 19 |
| 15 | 13 | 16 | 19 |
| 20 | 13 | 13 | 16 |
| 25 | 9  | 13 | 16 |
| 30 | 9  | 13 | 13 |
| 35 | 9  | 9  | 13 |
| 40 | 6  | 9  | 9  |
| 45 | 6  | 6  | 9  |

To calculate upright height add dimension 'a' to the guardrail height and + or - ground fixing dimension.

### Using fittings 129 & 130

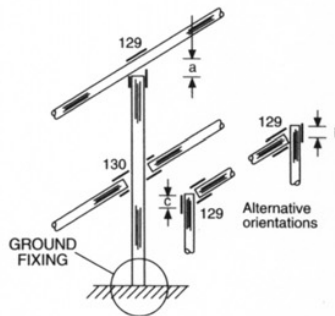

| Angle | 30° | 35° | 40° | 45° |
|-------|-----|-----|-----|-----|
| 2     | a   | -34 | -34 | -37 |
|       | b   | +24 | +18 | +11 |
|       | c   | +36 | +42 | +49 |
| 3     | a   | -40 | -44 | -48 |
|       | b   | +29 | +21 | +12 |
|       | c   | +44 | +52 | +61 |
| 4     | a   | -45 | -50 | -55 |
|       | b   | +33 | +24 | +14 |
|       | c   | +46 | +55 | +65 |

To calculate upright height select the correct orientation for the 129 fitting and then either add or subtract the dimension, + or - ground fixing dimension.

## HOW TO CALCULATE CORRECT TUBE LENGTH - CROSSRAILS

### Using fittings 126 & 127

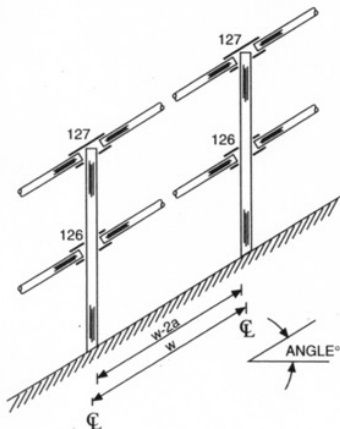

DIMENSION 'a'

|    | 2  | 3  | 4  |
|----|----|----|----|
| 0  | 19 | 23 | 26 |
| 5  | 22 | 25 | 29 |
| 10 | 25 | 29 | 33 |
| 15 | 25 | 33 | 35 |
| 20 | 29 | 33 | 38 |
| 25 | 33 | 35 | 42 |
| 30 | 35 | 42 | 45 |
| 35 | 39 | 45 | 52 |
| 40 | 42 | 49 | 57 |
| 45 | 48 | 55 | 64 |

To calculate the rail length subtract 2 x dim 'a' from the upright centres measured on the slope.

### Using fittings 129 & 130

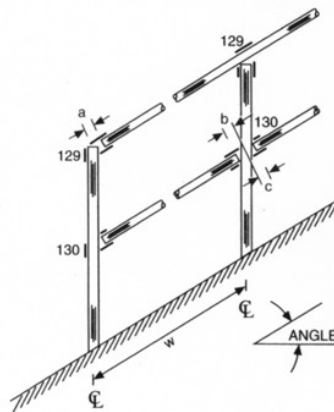

| Angle | 30° | 35° | 40° | 45° |
|-------|-----|-----|-----|-----|
| 2     | a   | 32  | 34  | 37  |
|       | b   | 55  | 51  | 48  |
|       | c   | 36  | 40  | 43  |
| 3     | a   | 40  | 45  | 49  |
|       | b   | 64  | 61  | 57  |
|       | c   | 41  | 45  | 49  |
| 4     | a   | 46  | 51  | 56  |
|       | b   | 78  | 74  | 64  |
|       | c   | 55  | 58  | 61  |

To calculate the rail length subtract the relevant dimensions from the upright centres measured on the slope.



# PIPECLAMPS

## BASES AND WALL PLATES

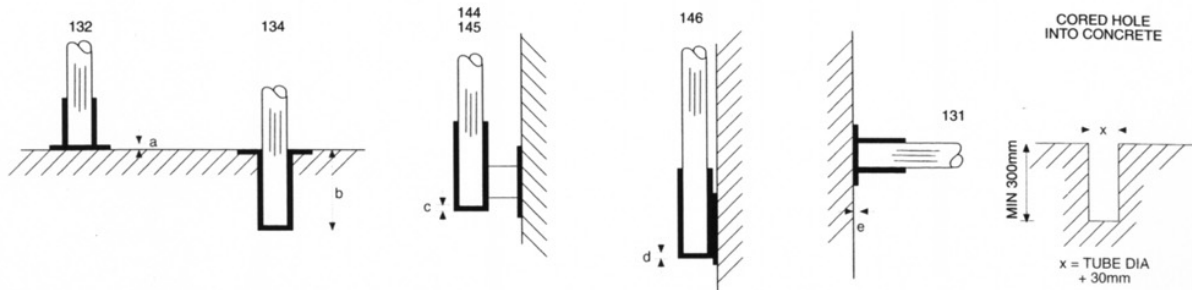

|   | a | b   | c | d | e |
|---|---|-----|---|---|---|
| 1 | 6 | -   | 5 | 5 | 6 |
| 2 | 6 | 115 | 5 | 5 | 6 |
| 3 | 6 | 127 | 6 | 6 | 6 |
| 4 | 6 | 127 | 6 | 6 | 6 |
| 5 | 6 | -   | 6 | 6 | 6 |

Dimensions a, c, d and e are to be subtracted from upright length.

Dimension b is to be added to the upright length.

For uprights cast into concrete pockets the upright must be flat on one end and the pocket min 300 x 300 x 300.

## WELDMESH INFILL PANNELLING

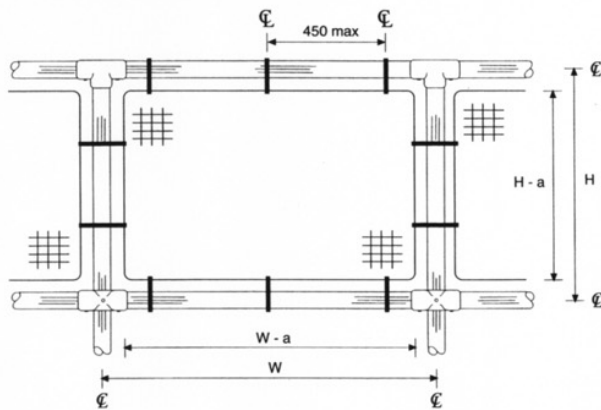

To calculate the width and height of a weldmesh infill panel use the following table and subtract the dimension.

|   | a  |
|---|----|
| 1 | 60 |
| 2 | 76 |
| 3 | 86 |
| 4 | 90 |
| 5 | 99 |

Panel height =  $H - a$

Panel width =  $W - a$

It is recommended that the weldmesh panel is framed with an 8mm rod.

Panel clip centres should be **no greater** than 450mm.

Mesh size under 35mm square will require cut outs in the mesh to accommodate the panel clip.

## INSTALLATION PROCESS FOR BASE WEATHER FLANGE

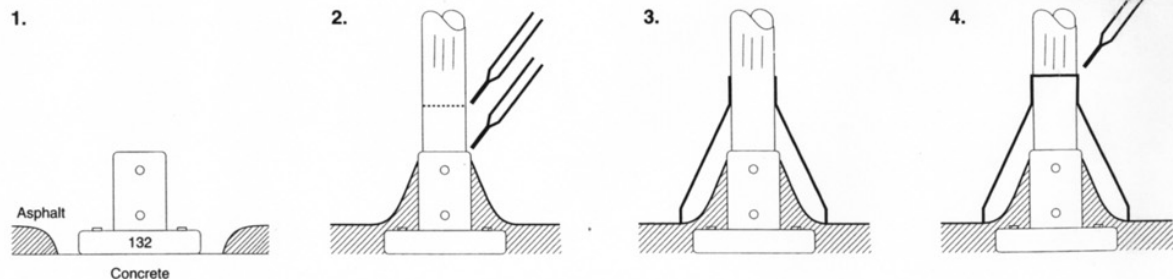

1. Remove all asphalt and fix Pipeclamp fitting 132 onto the roof.

2. Fix upright into 132 fitting and seal fitting to tube.  
Dress asphalt over 132 fitting.

3. Slide 192 weather flange down upright and over circle of sealant.

4. Seal top of the weather flange.  
Complete fixing guardrail.

Put a circle of sealant around tube. ....