

613 MULTI-SLICER

A STAPLE IN THE INDUSTRY OFFERS HIGH QUALITY SLICING, STACKING & PORTIONING



The 613 Multi-Slicer is ideal for food processors and foodservice providers that need a versatile, high quality slicer to automate their operations. It bulk slices, stacks and shingles portions of a variety of products quickly and consistently. With the 613 you control an additional step in your operation, increasing output and safety while ensuring consistent quality at a lower cost than pre-sliced products. Its user-friendly operation and sanitation allow for fast set-up, function selection and thorough cleaning.

- Slice, stack and shingle portions at up to 90 strokes per minute, per lane
- Easy-to-use touch screen panel for quick selection of a variety of functions
- Modular, mobile design makes it easy to move around your facility or kitchen
- Sanitary design with sloped services and easily removable parts allows for quick and thorough cleaning
- Disposable AccuBand® band blades eliminate resharpening, simplify clean-up and provide optimal slice quality, consistency and yield

COMMON FOOD APPLICATIONS

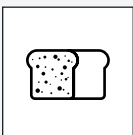

Bread

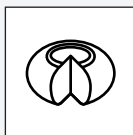

Cheese



Fresh Meats



Fresh Produce

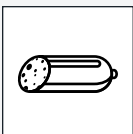

Lunch Meats



Plant-based



613 MULTI-SLICER

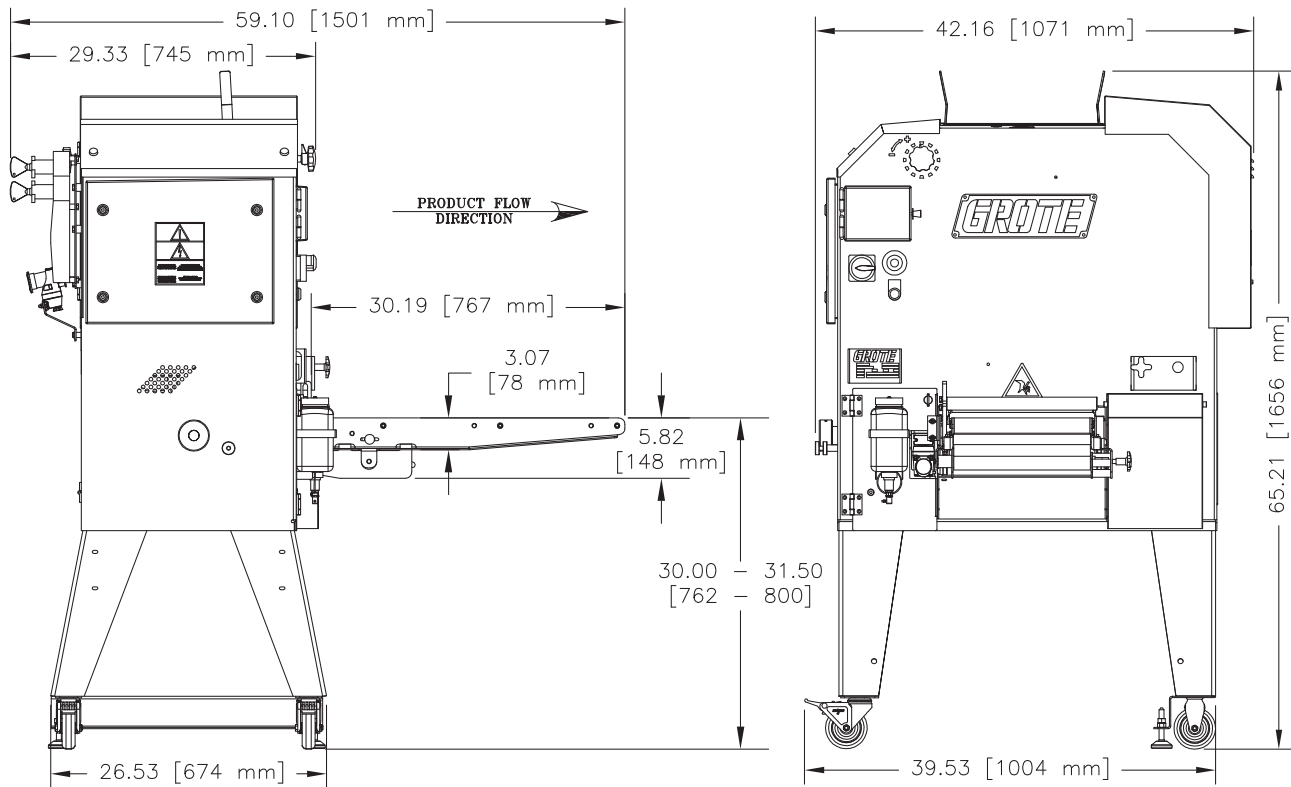

ALL DIMENSIONS ARE APPROXIMATE
PRIMARY DIMENSIONS IN INCHES

This drawing contains confidential information is the exclusive property of the J.E. Grote Co. Neither this document, nor its contents, are to be used, reproduced or disclosed in whole or in part without the express written permission of the J.E. Grote Co. Copyright 2017, J.E. Grote Company, Inc.

SPECIFICATIONS

Product Size: 6x13" (152x330 mm) maximum

Slice Thickness: .04-.50" (1-12.7 mm).
Thicker than .5" available upon request

Stack Height: Up to 2" (51mm)

Electrical: 200-240 VAC, 50/60 Hz, 1 Phase

FEATURES/PARTS

- AccuBand blades and blade guides
- Custom 26" (660 mm) tall product holders
- Carryout conveyor (extended length available)
- Safety enhancements including: interlocking latches, variable frequency drives and zero speed switch
- Slice counter for grouping

- Shuttle conveyor for stacking or shingling
- Variable speed conveyor

OPTIONS

- Pass-Through Conveyor & Targeting
- PPI Paper Sheeter

E 6.21v7

CONTACT US

Grote Company is proud to provide top quality equipment, exceptional service and peace of mind worldwide. Contact us for more information or to schedule a demo of the 613 Multi Slicer with your product in your exact operating conditions in our Demo Facility.



To feed our growing world - Together

sales@grotecompany.com
grotecompany.com