

Clamco 120 Combo

Dependable seal and shrink system

The Clamco Combo shrink system combines the L-Bar sealer and shrink tunnel for packing, sealing, and shrinking products. The sealer and tunnel share a common heavy-duty frame and base which allows for quick set up, alignment, and product transfer between the sealer and the tunnel.

The Clamco Combo system includes standard features such as a film cradle with a pinwheel perforator and a unitized package tray to assist in the fast and efficient placement of the product into the film.

The sturdy design of the Combo provides the framework for greater productivity and insures consistently strong seals. The use of integrated application specific controls allow for easy and fast operator set up and provides for years of trouble free operation.



Logical, user friendly control panel



Temperature controlled L-bar for consistent sealing



Adjustable workshelf height adds versatility

User benefits

- Temperature controlled system provides repeatable, strong seal
- Digitally controlled tunnel temperature with heavy-duty blower provides 360° air circulation for consistency and performance
- 11-gauge steel construction throughout for 24x7 productivity, with minimal maintenance
- Quick height adjustment facilitates centering the seal on the product
- Dwell control provides additional flexibility
- Powerful magnetic hold down for consistent trim seal pressure
- Film cradle can accommodate up to 20" wide roll of film
- Designed to seal and shrink most polyolefin and PVC films

Set-up benefits

- Logical, user friendly controls
- Adjustable unitized package tray and film cradle with pinwheel perforator for easy product loading

Operating benefits

- Adjustable airflow and variable tunnel conveyor speed to maximize shrink performance
- Seal temperature control provides repeatability of seal performance
- Tunnel curtain design minimizes heat loss and maintains tunnel temperature consistency

Safety benefits

- Designed to meet CE requirements
- Emergency stop buttons ensure quick machine shutdown



a PAC Machinery company

Options and Accessories

- Power take-away conveyor
- Variable speed power take-away conveyor
- Hot knife (220 Combo only)
- Scrap take-up wheel
- Short console stand (74") with film cradle underneath
- Tunnel—4 KW, 220V/Cold room—Severe operating conditions
- 2" Seal bar extension (22" Long)

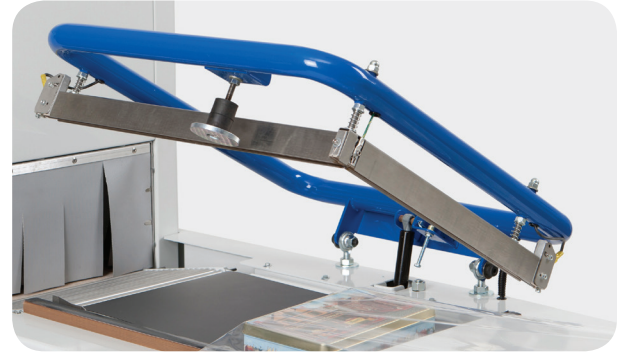

The Clamco Combo semi-automatic shrink packaging system includes many standard features combined with its comparatively lower price makes it the best value in its category.

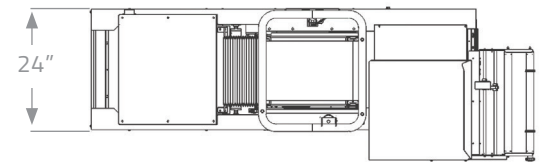
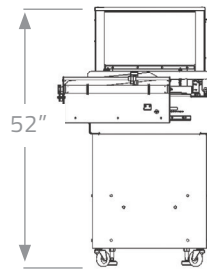
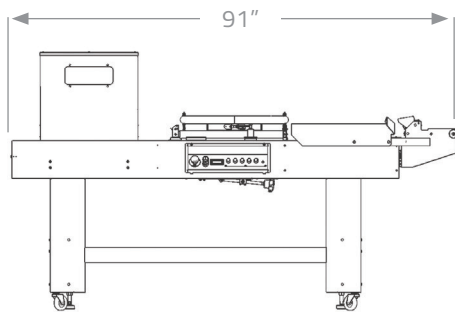

Technical Specifications

Model	Combo
L-Bar Seal Area:	16" W x 20" L
Max Film Width:	20" Centerfold
Tunnel Chamber:	16"W x 20"W x 8"H
Machine Dimensions:	91" L x 24" W x 52" H
120 Combo Electrical Requirements:	120V, 20 amp, 50/60 Hz, 2,400w
220 Combo Electrical Requirements:	220V, 20 amp, 50/60 Hz, 4,400w
Weight:	480 lbs.
Warranty:	2 year limited warranty

Features

- Heavy duty seal bar arm
- Independent seal temperature and dwell control
- Easy, operator friendly controls for fast set-up
- Heavy duty console stand with adjustable levelers
- Single heavy duty magnetic hold down
- Unitized, adjustable package tray and film cradle with pinwheel perforator and variable brake
- Tunnel heating power
 - 2100 Watts 120 Combo
 - 2300 Watts 220 Combo
- Automatic cool down timer
- Adjustable airflow and variable speed conveyor
- Made in USA

Contact us today:

(800) 985-9570 ■ sales@clamcopackaging.com



*Watch the 120 Combo
L-Bar Sealer & Shrink
Tunnel in action!*



a PAC Machinery company

775 Berea Industrial Parkway, Berea OH 44017 ■ (800) 985-9570 ■ www.pacmachinery.com
©2015 PAC Machinery all rights reserved. Specifications may change without notice