

SEAL-A-TRON

Shrink Packaging Equipment

SEGMENT 1

KOMBI WRAPPER 5 COMBINATION L-BAR SEALER & SHRINK TUNNEL

EQUIPPED
TO OUR NEW
ADJUSTABLE
STAND

L-BAR SEALER

Standard Features:

SEAL BAR DIMENSIONS: 16" W x 20" L x 6"H

- Hold up to a 20" wide roll of film
- Tru-Temp Digital Seal Wire Control
- Mag-LOK Extra Strong Magnets
- Lightly Balanced Seal Head Pivot
- EZ-Perf Venting Pin Perf
- Proximity Sensor Switching for Impulse Seal Wires
- Anodized Aluminum Seal Head with Film Clamps
- Heavy Duty Welded Frame with Locking Casters

Power Required: 120 VAC 12 Amp Service



Standard Digital Temp Controls

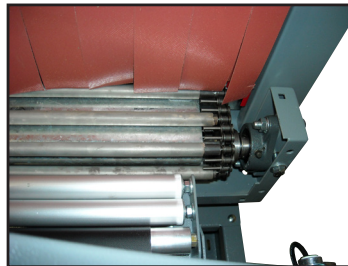

Live Roller

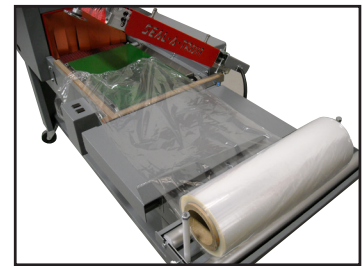

Holds a 20" Roll of Plastic



GFN Conveyor Upgrade

SHRINK TUNNEL

Standard Features:

TUNNEL DIMENSIONS: 15" W x 8"H x 30"L

- KOOL-TOUCH Exterior
- Surround Air Flow All 4 Sides
- .50" Live Rollers on 1.5" Centers
- Digital Temperature Controls
- Cool Down Cycle
- Parallel Shaft DC Motor driven by Chain and Sprocket
- Heavy Duty Shafts and Bearings
- Power Required:

220 VAC Single Phase 25 Amps Service

Options:

- Variable Speed Discharge Conveyor
- GFN Glass Filled Nylon Conveyor Belt for Tunnels

Seal-A-Tron Corporation™ • 3815 S.E. Naef Road. • Portland, OR 97267 • Phone (503) 652-5200

Visit us on the Internet at: <http://www.seal-a-tron.com>

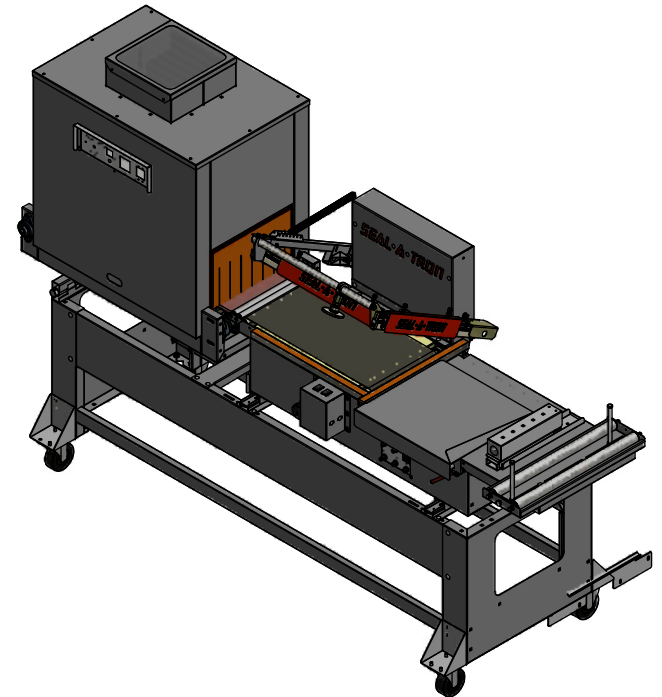
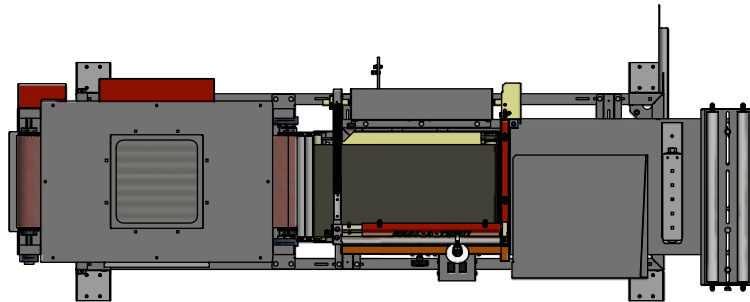

KR5 SEALER AND TUNNEL

OS-1620 L-BAR SEALER
120Vac - 12Amp - Single Phase

OT-1508-30 SHRINK TUNNEL
220Vac - 25Amp - Single Phase

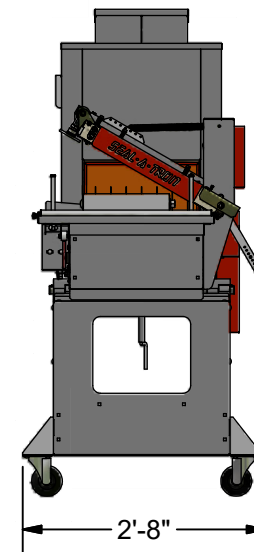
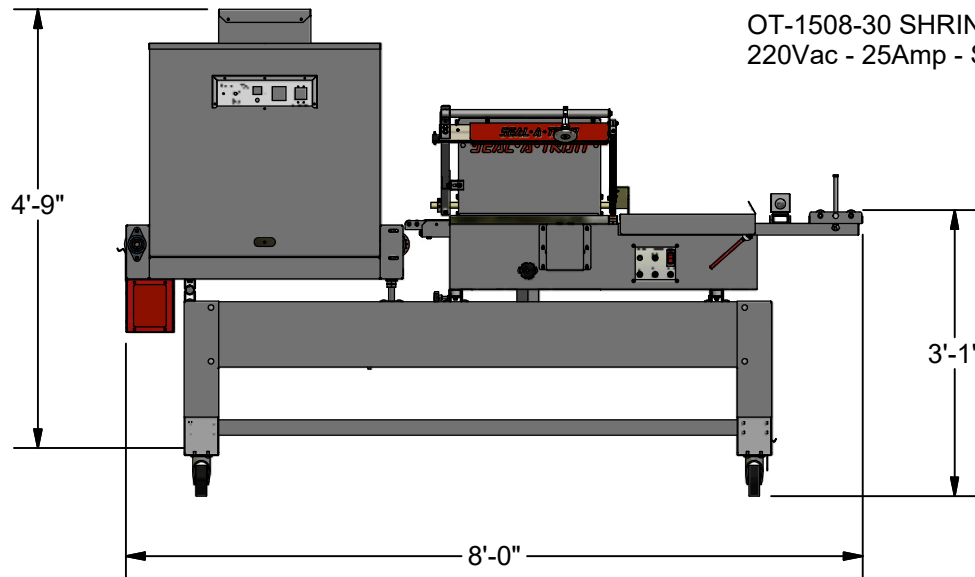

SEALATRON

TITLE: KR5 - SEALER AND TUNNEL		SIZE A
PART # KR5	PG 1 OF 1	REV. A