

DT-125-1C

ECONOMICAL SINGLE COLOR PAD PRINTING MACHINE



DT-125-1C
single color model

- Simple to operate using touch panel
- Microprocessor controlled
- SMC pneumatics
- Easily accessible pad stroke adjustments
- X/Y/R/Z work table
- X/Y/R cliché adjustment
- Smooth & quiet machine performance



solutions in pad printing™

DT-125-1C

ECONOMICAL SINGLE COLOR PAD PRINTING MACHINE

The **DT-125-1C** pad printing machine is a compact and economical one color pad printing system that is both user-friendly and quick to setup. It features a membrane control panel on the front faceplate and the easily accessible pad stroke controls are on the right side of the machine with numerical calibration. The **DT-125-1C** pad printer comes with a solid built welded steel machine base and it has adjustable floor levelers and a height adjustable work table. Inside the machine base you have room to store your pad printing supply items like; inks, thinners, ink cups, mixing cups, stir sticks, etc. This **DT-125-1C** is equipped with one ink cup (see specs below for size) and a X/Y/R adjustable cliché holder for precise alignment of artworks. The clichés can be; photo polymer, thin steel or laser etched varieties and **DECO TECH** provides a full array of consumable supplies, technical support & product training for our **DT SERIES** of pad printing machinery. This **DECO TECH** pad printing machine is backed with a one year warranty against defects in manufacturing.

MACHINE SPECS

Printing capacity:	Up to 1,800/hr
Drive:	Electro-pneumatic
Printing force:	629N
Vertical pad stroke:	125mm (4.92")
Air requirements:	5-6 bar (87psi)
Air consumption:	3 cfm @ 80psi
Control system:	12V PCB
Main voltage:	110 - 220V 50-60Hz
Control voltage:	24 VDC
Weight:	80 kg (176 lbs)
Origin:	China

PRINT SPECS

Plate sizes:	100 x 215mm (Standard) 100 x 200mm (Optional)
Plate thickness:	0.5mm or 10mm
Ink cup size (ID): 90mm (3.54")	Print size (diameter): 80mm (3.14")

*Specifications are subject to change without prior notification

DIMENSIONS

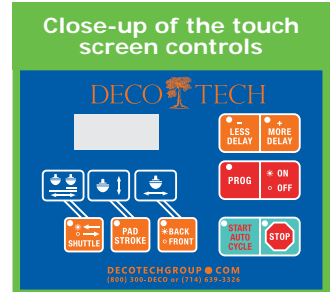
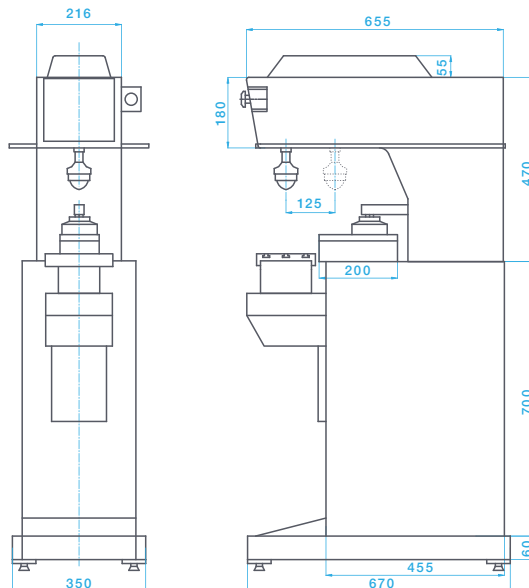

01/31/14 Rev A



© Deco Technology Group, Inc. All rights reserved.

DECO TECHNOLOGY GROUP, INC.
 749 N. MAIN STREET
 ORANGE, CA 92868
 ☎ (800) 300-DECO
 ☎ (714) 639-3326
 ☎ (714) 639-2261
DECOTECHGROUP.COM