



RTP 10i[®] Tablet Press User Manual



We don't just sell machines—
we provide service.

Copyright Notice

© LFA Machines Oxford Limited, published in 2020 by LFA Machines Oxford Limited 2020. Registered in England and Wales, company number 08428898, registered office for service Demar House 14 Church Road East Wittering, Chichester, West Sussex, PO20 8PS.

All rights reserved. No part of this publication may be reproduced or transmitted, in any form or by any means, or stored in any retrieval system of any nature, without prior permission, except for fair dealing under the Copyright, Designs and Patents Act 1988, or in accordance with the terms of license issued by the Copyright Licensing Agency in respect of photocopying and/or reprographic reproduction. Application for permission for other use of the copyright material including permission to reproduce extracts in other published works shall be made to the publisher. Full acknowledgment of author, publisher and source must be given.

All trade marks are acknowledged and are owned by their respective owners.

Important Safety Information

READ THIS BEFORE OPERATING MACHINE

Intended Use

The intended use of this machine is to press dry raw materials into tablet form.

Potential misuse of this machine includes:

- Applying too much force to the powder.
- Trying to fill the Dies with powder by hand.
- Inserting Tooling that is too big for the machine.
- Using powders that could explode under pressure.
- Using wet or damp material.

Personal Protection

For personal protection while transporting the RTP 10i®, abide by these actions:

- Use a forklift to lift the machine.
- Wear steel toe boots to prevent foot injury.
- Wear heavy duty grip gloves to ensure firm grasp on machine.
- Wear back support belt to prevent injury if needed.

For personal protection while operating the RTP 10i®, abide by these actions:

- Avoid wearing loose jewelry to prevent machine entanglement.
- Contain long hair to prevent machine entanglement.
- Wear safety goggles.
- Wear disposable latex/rubber gloves.
- Wear a hairnet (food grade products only).
- Wear a beard net if needed (food grade products only).

General Hazards

In the case of an emergency during operation, immediately push the Emergency Stop button.

- Be aware of risk of entanglement and pinch point due to moving parts.
- Do not operate in a wet environment or with wet hands due to risk of electrical shock or burn.
- Do not operate if any wires are exposed in cables due to risk of electrical shock or burn.
- Keep out of reach of children.
- Keep fingers away from all moving parts.
- Ensure that it is securely against the workspace surface.
- Inspect machine before use.
- Check that nuts and bolts are suitably tightened.
- Use this machine only for its intended use as described in this manual.
- Do not modify the machine in any way.
- Turn off and unplug the machine before conducting cleaning and maintenance.

Important Safety Information

READ THIS BEFORE OPERATING MACHINE

Symbols



WARNING

This signals potential risk for personal injury.



WARNING

This signals potential risk for electrical shock.



CAUTION

This signals potential risk for damage to the machine or other parts.

Modes for Stopping

In the case of an emergency during automatic operation, immediately unplug the RTP 10i® and/ or push the Emergency Stop button:



Table of Contents

Copyright Notice	2
Important Safety Information	3
Intended Use	3
Personal Protection	3
General Hazards	3
In the case of an emergency during operation, immediately push the Emergency Stop button.	3
Important Safety Information	4
Symbols	4
Modes for Stopping	4
RTP 10i® Components	6
RTP 10i® Electrical Components (front)	7
RTP 10i® Electrical Components (back)	8
Preface	9
Training	10
On-Site/Off-Site Training	10
Training via Video Chat/Phone	10
LFA Articles	10
LFA Videos	10
Installation	11
Tools and Materials Needed	11
The Appropriate Workstation for the Machine	11
Assembly	14
Positioning the RTP 10i®	14
Controls	15
Settings and Adjustment	19
Maintenance	28
General Maintenance Prescriptions	28
Lubrication	28
Dismantling for Repair and Replacement	32
Wear Parts and Causes of Damage	33
Tooling	34
Force Feeder Wear Plate	43
Take-Off Blade and Force Feeder Scraper	46
Adjustment Knobs	51
Troubleshooting	53
Common Machine/Part Issues	53
Common Tablet Issues	55
De-Jamming the RTP 10i®	56
Cleaning	57
Storing the RTP 10i®	63
Appendix	65
Glossary	65
Description of RTP 10i® Parts	66
Material of Contact Parts	74
Technical Specifications	74
Maintenance Checklist	75
Diagrams	76
Resources	82

RTP 10i[®] Components

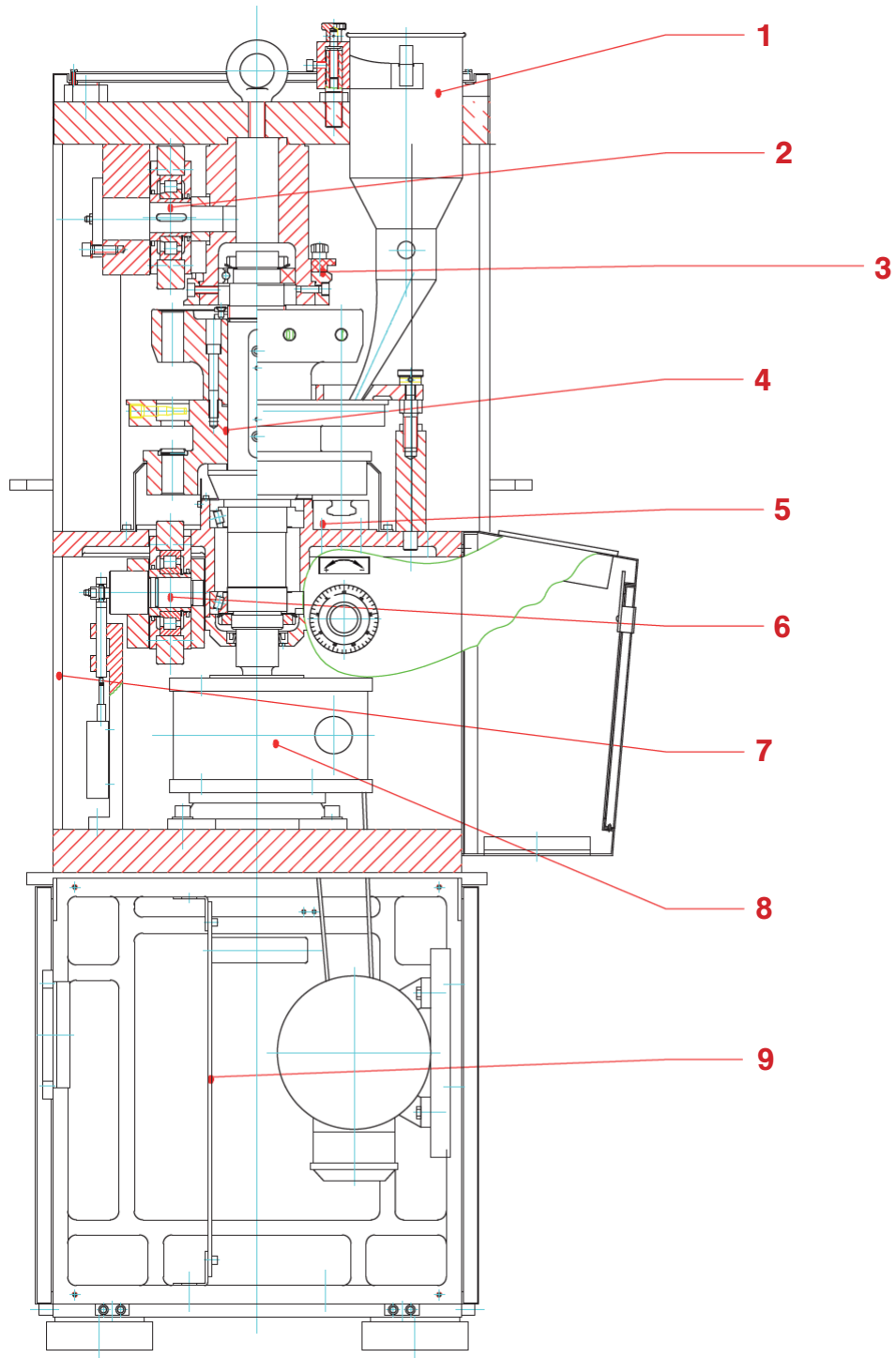

- 1. Hopper
- 2. Upper Roller Cam
- 3. Upper Tracking Key
- 4. Main Turret

- 5. Lower Tracking
- 6. Lower Roller Cam
- 7. Machine Panel Door (Back)
- 8. Worm Gear
- 9. Electric Mounting Board

RTP 10i[®] Electrical Components (front)



WARNING

Only qualified electricians should work with these controls.

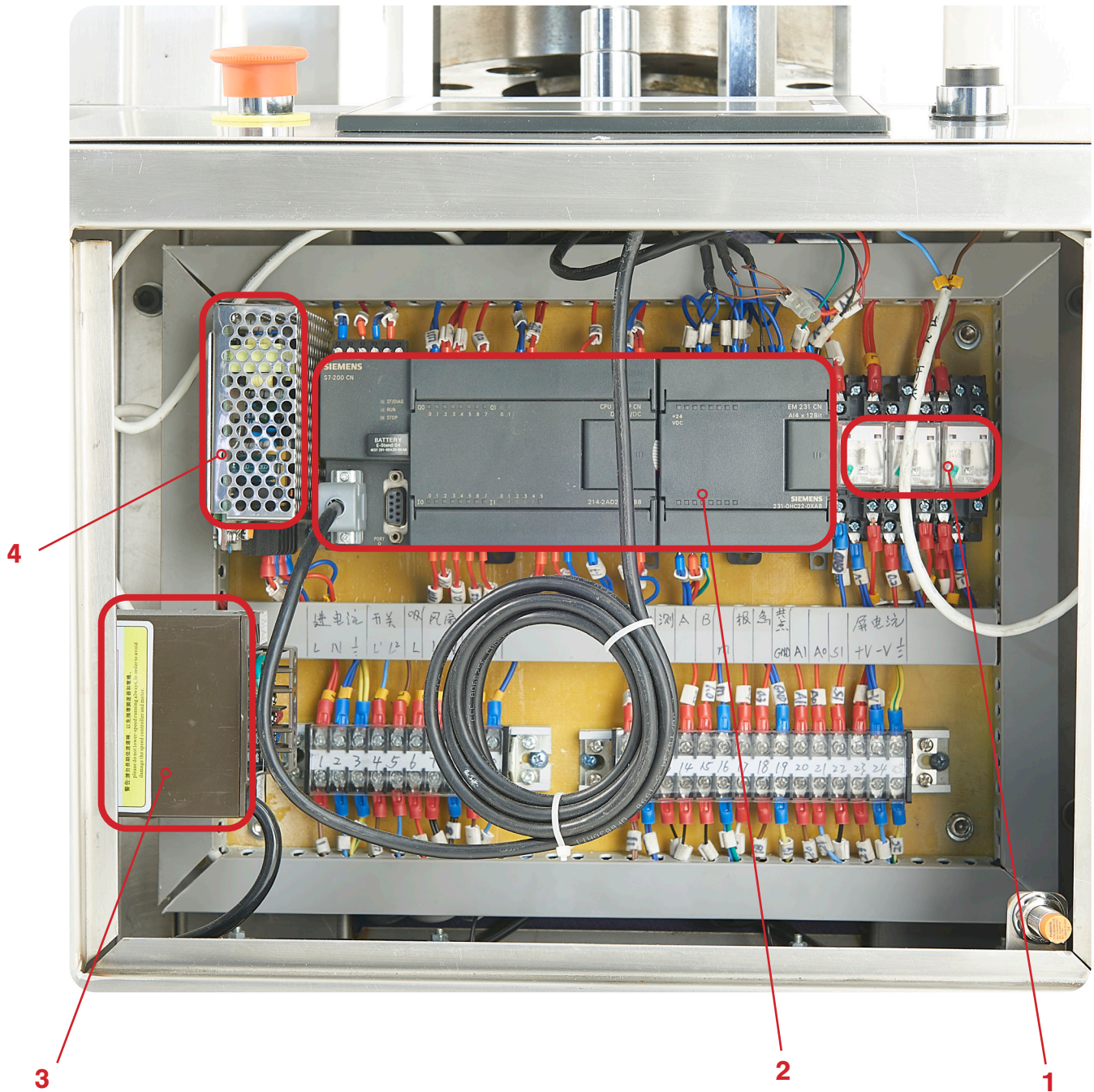

1. Solenoid switches for Motor, Vacuum, and Force Feeder

(HMI)

3. Force Feeder Controller

2. Programmable Logic Controller (PLC) for Human Machine Interface

RTP 10i[®] Electrical Components (back)



WARNING

Only qualified electricians should work with these controls.

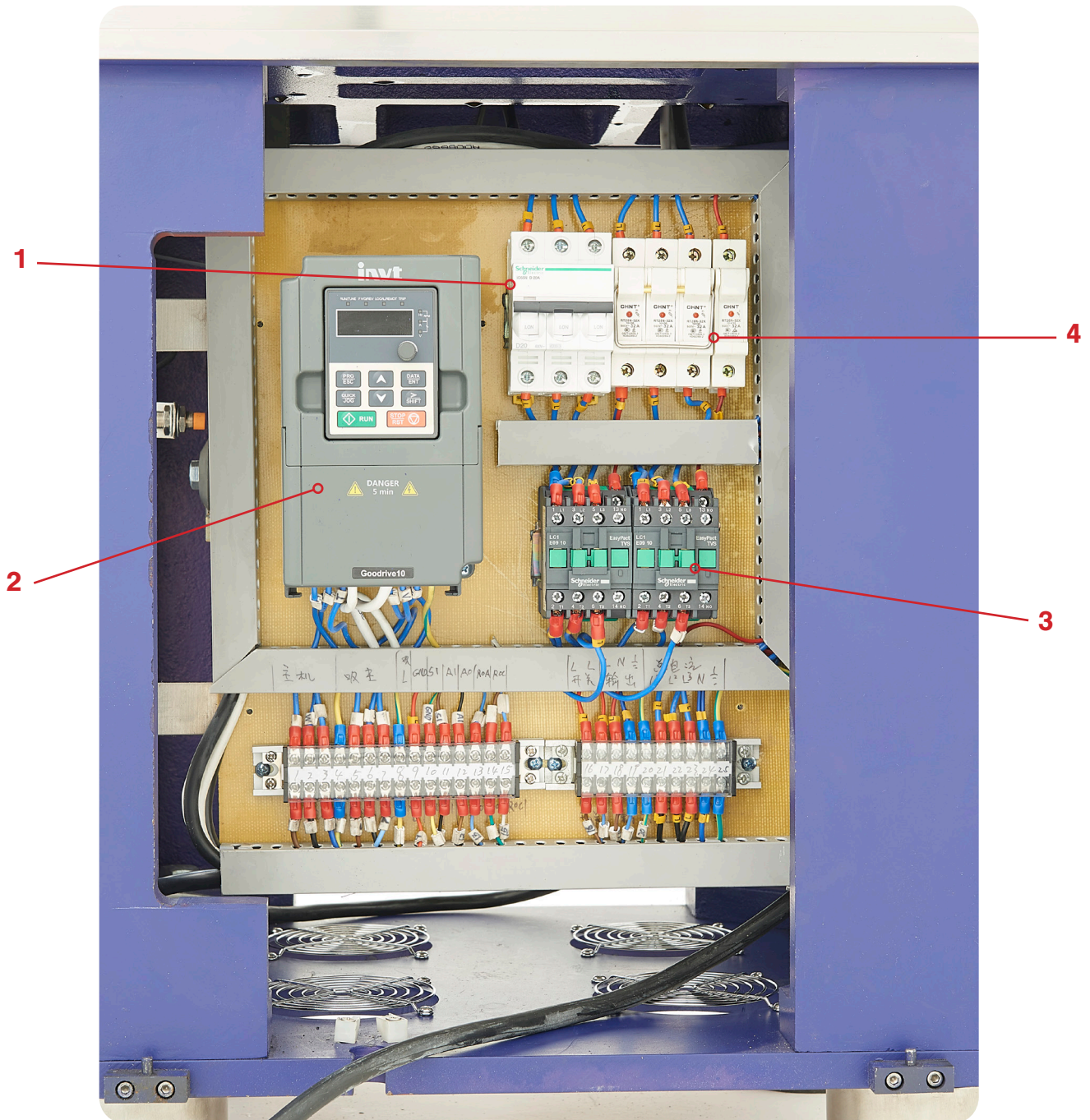

- 1. Breaker
- 2. Variable frequency drive (for motor speed)

- 3. Solenoid switches for Vacuum and Force Feeder
- 4. Fuses

Preface



The RTP 10i[®] is an intelligent rotary tablet press that uses a touch screen digital display and control to efficiently and accurately produce high quality tablets. With a fast 2.2 kW motor and ten sets of Tooling, the RTP 10i[®] has the ability to make up to 12,000 tablets an hour. Particularly popular in the pharmaceutical, chemical, food, and electronic industries, the RTP 10i[®] has been designed for fast production with an emphasis on safety and ease of use.

The purpose of this document is to support your understanding of the RTP 10i[®]'s components, features, functions, and design. With this manual, you will be able to successfully operate and maintain your RTP 10i[®] machine.

The user manual's content includes:

- Important safety information
- RTP 10i[®] installation instructions
- Description of the RTP 10i[®]'s operation
- RTP 10i[®] maintenance information
- Appendix with supplemental information

Training

RTP 10i® training is essential for the machine's successful operation and your personal safety. There are several methods to prepare you for working with the RTP 10i®.

On-Site/Off-Site Training

LFA technicians can travel and train you at your own facility with your own machines. LFA also offers free training at our UK, USA, and Taiwan facilities for all our customers and their teams. For more information, go to <https://www.lfatabletpresses.com/services>

Training via Video Chat/Phone

Using an online video chat system, an LFA technician can interact face-to-face with you and assist with your understanding of the machine. Or, if you prefer, LFA can provide training via phone for all customers who call the office. To set up a training, call or email your local LFA office:

UK

Phone

+44 (0) 0345 165 20 25

Email

sales@lfamachines.com

USA

Phone

(682) 312-0034

Email

sales.usa@lfamachines.com

Taiwan

Phone

+886 2773 74704

Email

sales.asia@lfamachines.com

LFA Articles

LFA writes informative articles about tablet presses, which includes instructions, procedures, and guides. To access the articles, go to <https://www.lfatabletpresses.com/articles>

LFA Videos

LFA has created several videos involving the RTP 10i® and other tablet presses. To access the videos, go to <https://www.lfatabletpresses.com/videos> or <https://www.youtube.com/user/TabletPilPress>

Installation

Tools and Materials Needed

Before you install and operate the RTP 10i®, it is best to have the following tools and materials on hand for general operation and maintenance:

- Forklift
- Lifting strap
- Level
- Crowbar
- Hammer
- Rubber mallet
- Metric wrench set
- Crosshead screwdriver
- Flathead screwdriver
- Set of metric Allen keys with ball ends
- Long wire pipe cleaner
- Cleaner (e.g. Member's Mark Commercial Lemon Disinfectant)
- Sanitizer (e.g. Member's Mark Commercial Sanitizer)
- Lubricant (NSF approved type for food grade products)
- Grease gun
- Toothbrush
- Cleaning brush set
- Plastic sheet or something similar to cover machine
- Safety goggles
- Hairnet and/or beard net (food grade products only)
- Sterile shoe covers (food grade products only)

The Appropriate Workstation for the Machine

The floor on which the machine is to be placed must support the RTP 10i®'s 500 kg (about 1,100 lbs) weight. The static floor loading limit is 2.43 kN/m².

Environmental Conditions

It is important that the environment in which you operate and store the RTP 10i® has the appropriate temperature and relative humidity levels. These two environmental factors can potentially cause the machine to rust and/or cause the tablets to have a lower quality. The table below shows the acceptable temperature and relative humidity levels:

Machine	Temperature		Humidity
	°C	°F	
RTP 10i®	0-40	32-104	20-80% RH

The shipping crate will contain the following:

1. The assembled RTP 10i®



2. The Tooling (already installed)

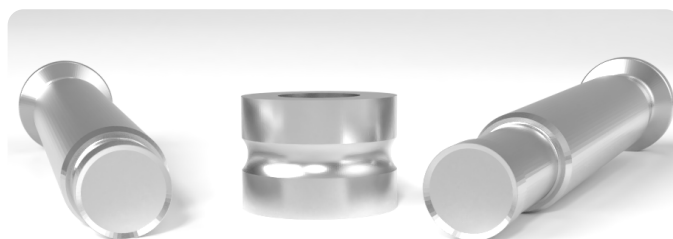

3. Toolkit including:



Note: Door keys not needed for RTP 10i®.

- Die Installation/Removal Bar
- Grease guns
- Crosshead screwdriver
- Flathead screwdriver
- Wrenches
- Allen key set

Unpacking the RTP 10i®

Tools Needed

- Crowbar
- Hammer
- Socket set or impact driver

Instructions

1. Remove the nuts and bolts from the shipping container's base with a socket set or impact driver.
 - 1.1 Note: Keep the nuts, bolts, and the shipping container's base in case you need to return the RTP 10i®.
2. Pry apart the shipping container with a crowbar until the machine is accessible for a forklift.

Assembly

The RTP 10i® also comes with anti-vibration feet to insert underneath its base's four corners. The anti-vibration feet not only absorb noise and vibrations, but also reduce the machine's movement. The anti-vibration feet's assembly must be done while the machine is suspended in the air with a forklift during its positioning.

Positioning the RTP 10i®

WARNING: To prevent personal injury, wear steel toe boots and heavy duty grip gloves while transporting the RTP 10i®.



Because of its 500 kg (around 1,100 lbs) weight, LFA does NOT recommend carrying the machine manually but rather with a forklift. At least two people should be involved (one operating the forklift and one stabilizing the machine) in removing the machine from the shipping container and placing it in the workspace.

Moving the RTP 10i® with a Forklift

Tools Needed

- Forklift that is rated to lift at least 1,000 kg
- Lifting straps that are rated for at least 1,000 kg
- Heavy duty grip gloves
- Steel toe boots

Instructions

1. Insert the eyelet bolt into the top of the machine.
 - 1.1 Note: Make sure that the eyelet bolt is securely tightened.
2. Feed the lifting straps through the eyelet bot.
3. Position the forks of a forklift truck over the top of the RTP 10i® and securely attach the lifting straps.
4. Unbolt the RTP 10i® from the metal pallet.
5. Carefully lift the RTP 10i® off the pallet and attach the anti-vibration feet.
6. Lower the machine so that it is no more than 2-3 cm off the floor.
7. Position the RTP 10i® in the desired location and carefully lower the machine.

Controls

Basic Components

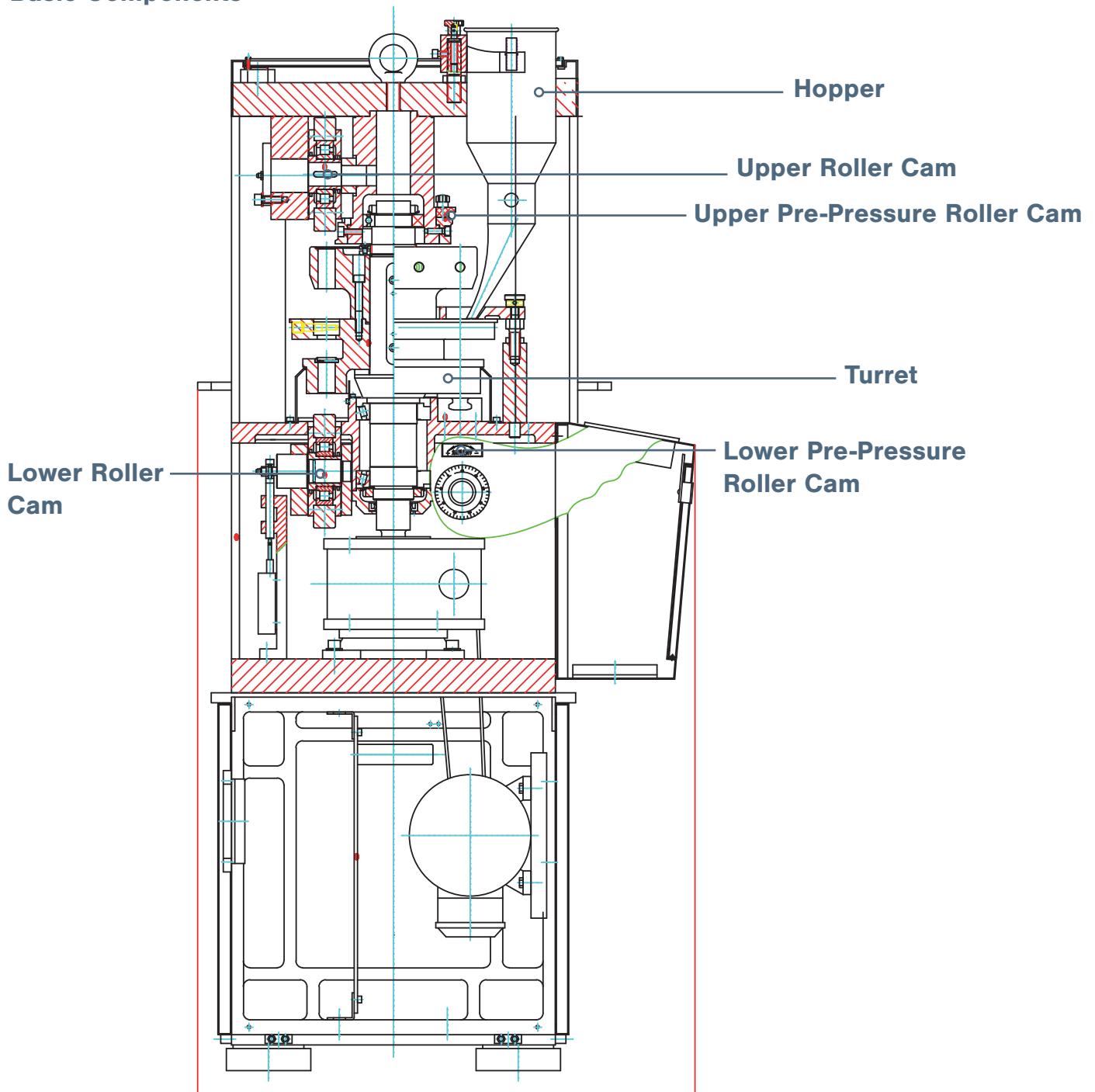

A description of the principal components follows:

- The **Hopper** holds the dry materials that will be compressed.
- The **Force Feeder** distributes the dry materials into the Die bores and its Take-Off Blade pushes tablets into the Tablet Chute (not pictured above).
- The **Dies** define the size and shape of the powder.
- The **Upper Punches** and **Lower Punches** compress the materials within the Dies.
- The **Turret** houses the Tooling.
- The **Upper Pre-Pressure Roller Cam** and **Lower Pre-Pressure Roller Cam** provide the initial compression force onto the powder to remove any air within the Die bore or powder particles.
- The **Upper Roller Cam** and **Lower Roller Cam** compress the Upper Punches and Lower Punches to create the tablet.

Control Console

To watch a video of an introduction to the RTP 10i's digital screen controls, go to <https://www.lfatablepresses.com/rtp10i-screen-introduction>

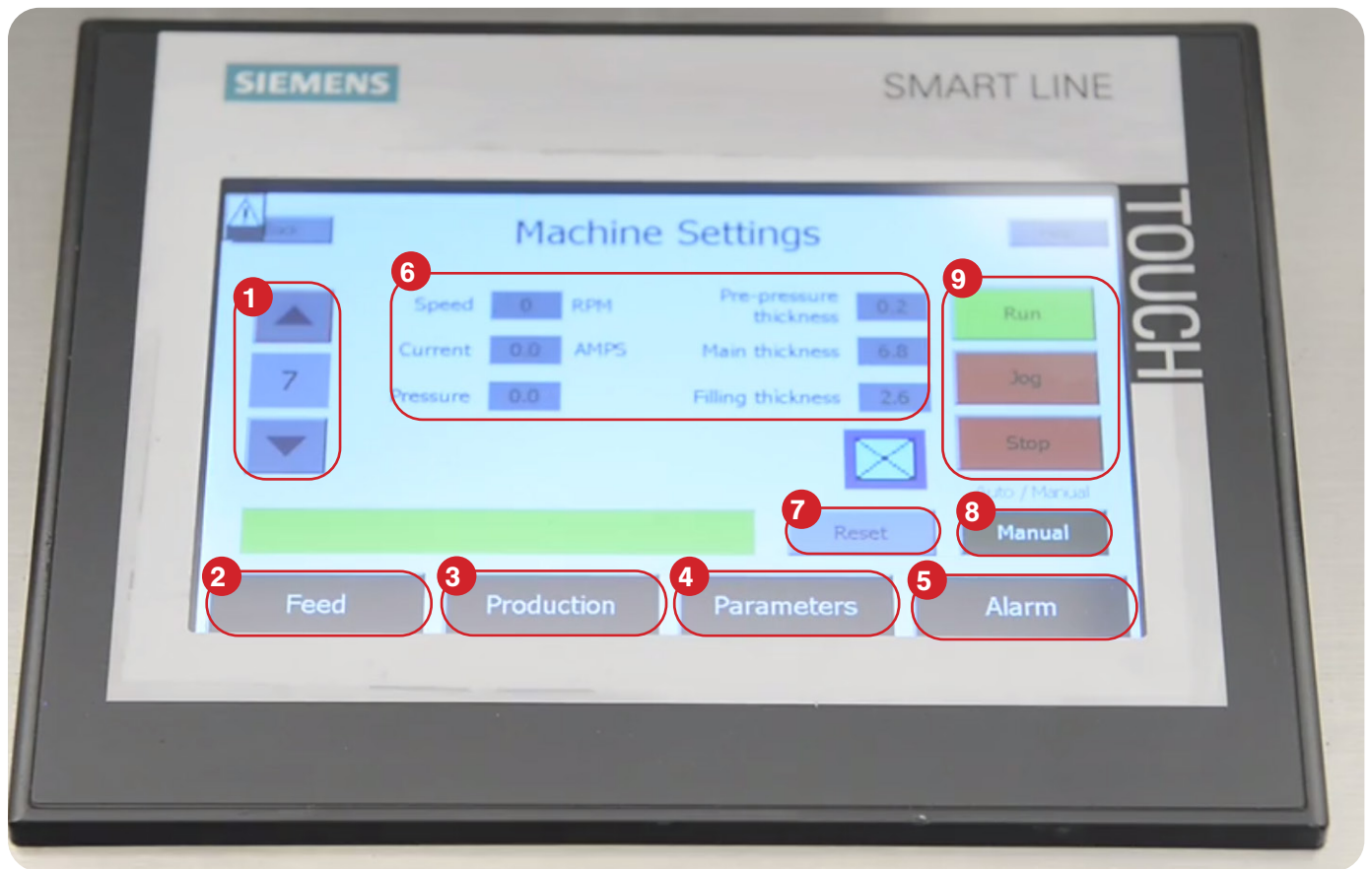

1. Adjusts Turret speed.
2. Runs/jogs the Force Feeder and/or Vacuum.
3. Shows how long the machine has been running, how many tablets have been produced, and the pressure levels during production.
4. Sets parameters for pressure, current, transmission ratio, and station quantity and also shows the preset parameters that come with the machine.
5. Shows alarm warning messages.
6. Displays current settings for production.
7. Resets all adjustments.
8. Switches between Auto and Manual run.
9. Starts machine operation (Run), slowly operates machine (Jog), and cuts off operation (Stop).

RTP 10i® Process

The basic mechanism of the RTP 10i® involves filling the Tooling (Dies, Upper Punches, and Lower Punches) with powder, compressing the powder, and ejecting the tablets.

Filling the Tooling with Powder

The dry materials are poured into the Hopper and funneled into Force Feeder via the connecting pipe. As the machine operates, the Turret moves, which causes the Upper Punches to withdraw from the Dies. During this process, powder is fed by the Force Feeder into the moving Turret and the Die bores.

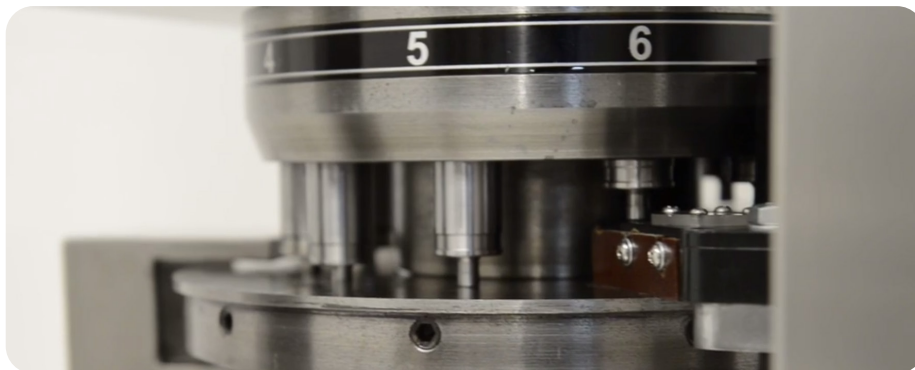

Compressing the Powder

After the Die bore is filled with powder, the Upper Punch is driven into the Die. The Upper and Lower Punches then compress the powder under high pressure.

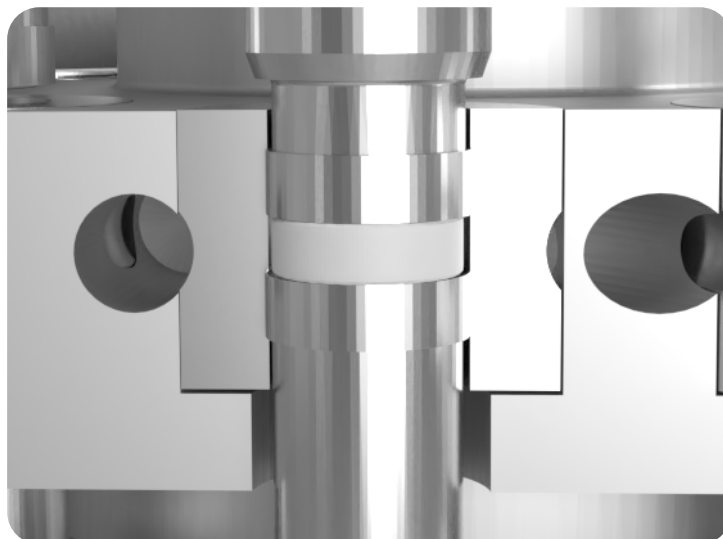
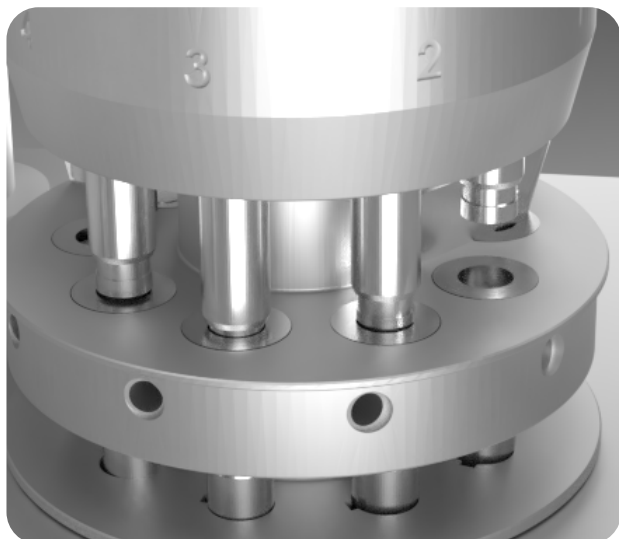

Ejecting the Tablet

After both punches compress the powder into a tablet, the Upper Tooling is withdrawn and the tablet is then pushed out of the Die bore by the Lower Punch. Once the tablet has been ejected out of the Die bore, it is slid out of the way by the Force Feeder's Take-Off Blade to prepare for the next tablet compression.

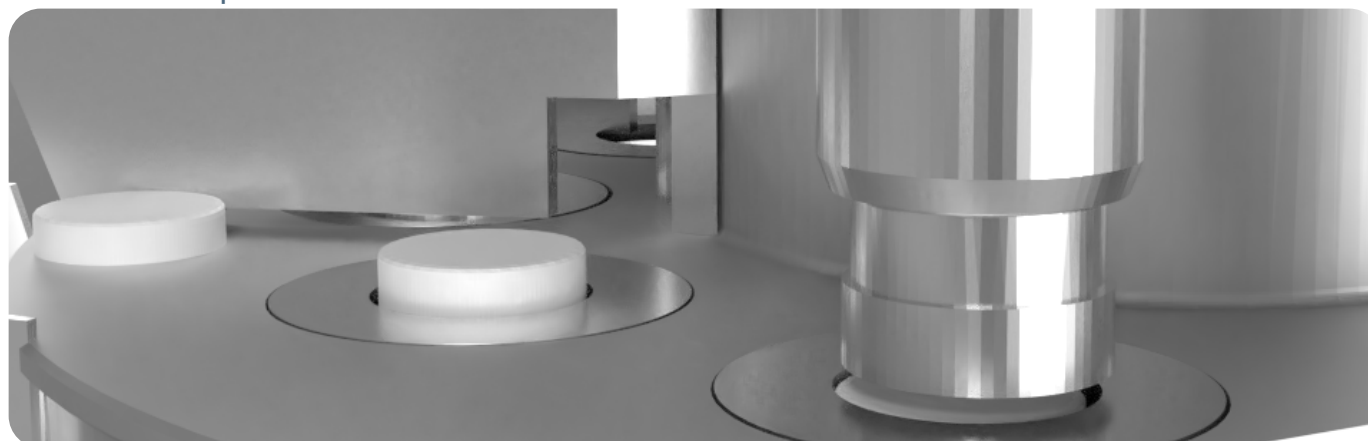

How to Create Tablets with the RTP 10i®

Tools and Materials Needed

- Raw material formulation
- RTP 10i®
- Safety goggles
- Disposable latex/rubber gloves (for food grade products and to protect hands from grease)
- Hairnet and/or beard net (food grade products only)
- Sterile shoe covers (food grade products only)



WARNING: To prevent any potential personal injury, unplug the RTP 10i® from the electrical outlet when manually operating the machine.

Instructions

Note: Wear latex/rubber gloves (and appropriate food grade attire if applicable) during this process.

1. Pull off the upper righthand side panel door.
2. Pull out the handle on Hand Wheel.

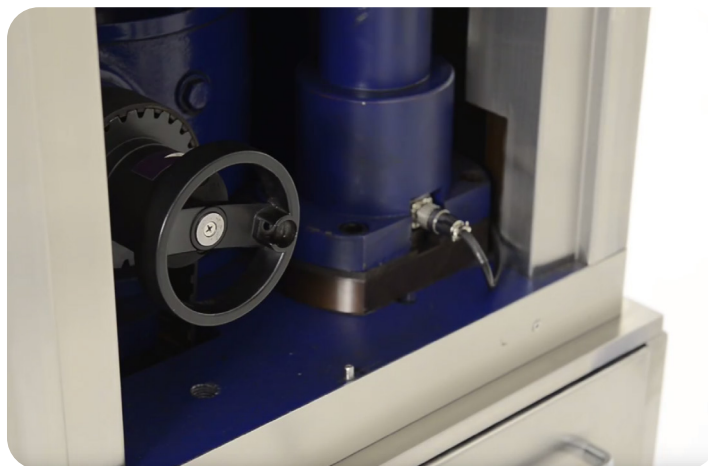

3. Turn the Hand Wheel manually clockwise for one full Turret rotation to ensure proper machine operation.
4. Pour the dry materials into the Hopper and manually press a tablet to avoid the chance of jamming the machine.
5. Push in and lower the Handle in its previous position and reinsert the panel door.
6. Plug in the RTP 10i® to an outlet.
7. Start up the machine's digital touch screen by turning the key on the front console to the right.
8. Touch the Start button on the digital screen.
9. Choose your preferred language by pressing the relevant button.
10. Press the Run button on the digital screen to start tablet compression.

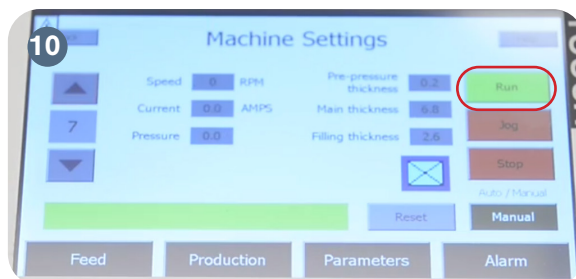
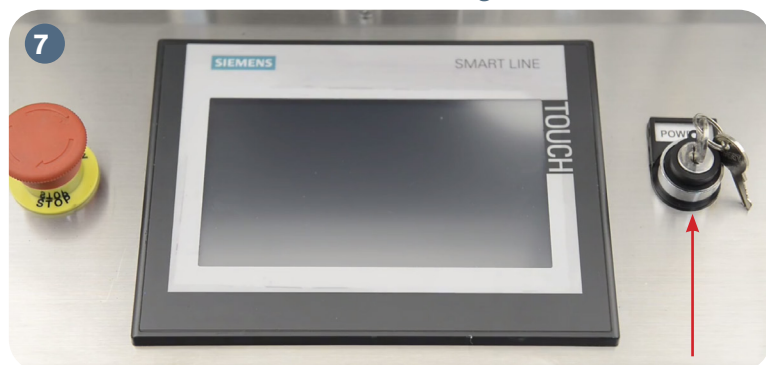

Settings and Adjustment

The RTP 10i®'s settings can be adjusted. Tuning the machine can help with changing the tablets' characteristics.

Fill Depth

At times, a tablet will be too small or too large, and its weight must change. This simple adjustment determines the tablet's weight.

Tools and Materials Needed

- Disposable latex/rubber gloves (for food grade products and to protect hands from grease)
- Hairnet and/or beard net (food grade products only)
- Sterile shoe covers (food grade products only)



WARNING: To prevent any potential personal injury, unplug the RTP 10i® from the electrical outlet.

Instructions

Note: Wear latex/rubber gloves (and appropriate food grade attire if applicable) during this process.

1. Produce test tablets to determine how the machine should be adjusted.
2. Turn the rightmost innerknob counterclockwise to unlock the fill depth adjustment knob.
3. Rotate the rightmost knob on the console to change the fill depth.
 - 3.1 Note: To increase the weight rotate the knob counterclockwise (this lowers the Dosing Cam). To decrease the weight rotate the knob clockwise (this raises the Dosing Cam).
4. Turn the rightmost innerknob clockwise to lock the fill depth adjustment knob.



Force Feeder Height

The size of granules in your powder can affect how smoothly dry materials are moved through the Force Feeder, which can affect how much powder is wasted. Sometimes this requires the Force Feeder's height to be adjusted.

To watch a video of Force Feeder calibration, go to <https://www.lfatabletpresses.com/rtp10i-force-feeder-calibration>

Tools and Materials Needed

- Set of metric Allen keys
- Feeler gauge
- Wrench set
- Level
- Disposable latex/rubber gloves (for food grade products and to protect hands from grease)
- Hairnet and/or beard net (food grade products only)
- Sterile shoe covers (food grade products only)



WARNING: To prevent any potential personal injury, unplug the RTP 10i® from the electrical outlet.

Instructions

Note: Wear latex/rubber gloves (and appropriate food grade attire if applicable) during this process.

1. Raise each of the Perspex Casing's doors and lock them into an upward position.
2. Unscrew the Powder Shutoff Gate's bolt by hand and remove the Hopper and the Hopper to Force Feeder Connecting Pipe from the RTP 10i®.
3. Loosen the Force Feeder's 17 mm bolts with a wrench and remove them.
4. Remove the Force Feeder from the RTP 10i®.



5. Loosen the Force Feeder Height Adjustment Base with an Allen key.
6. Adjust the three Force Feeder Height Adjusters with a wrench/by hand.
 - 6.1 Note: To raise the Force Feeder Adjustment Base, turn counterclockwise. To lower the Force Feeder, turn clockwise.

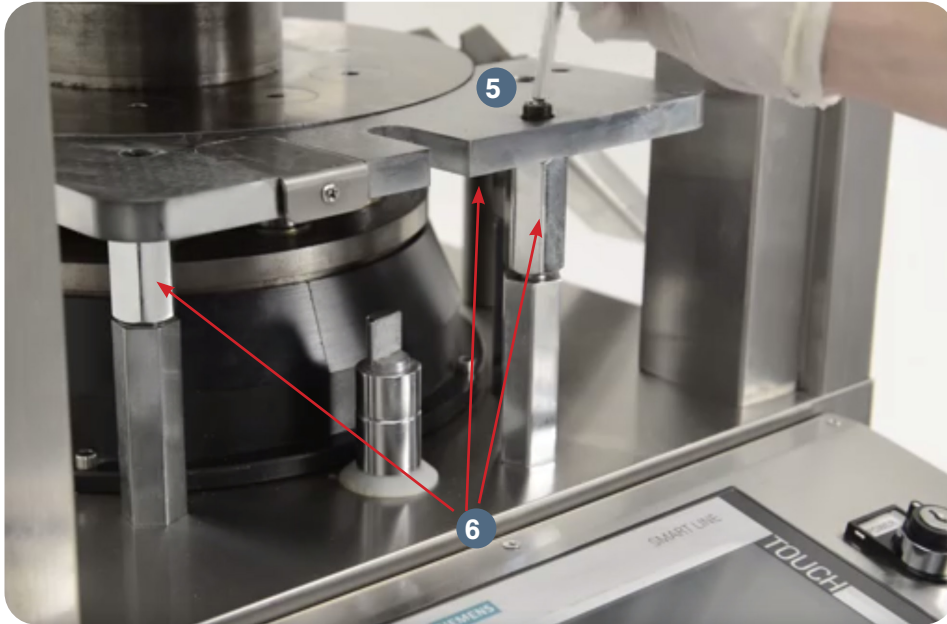

7. Place a level on the Force Feeder Adjustment Base and make any necessary adjustments to ensure that it is flat.
8. Place the Force Feeder back on the Force Feeder Adjustment Base and run a feeler gauge underneath the Force Feeder to determine the adjustment.
 - 8.1 Note: Start at 0.15 mm and raise appropriately if there is no powder waste/damage to the Force Feeder Adjustment Base. If there is waste, lower it.

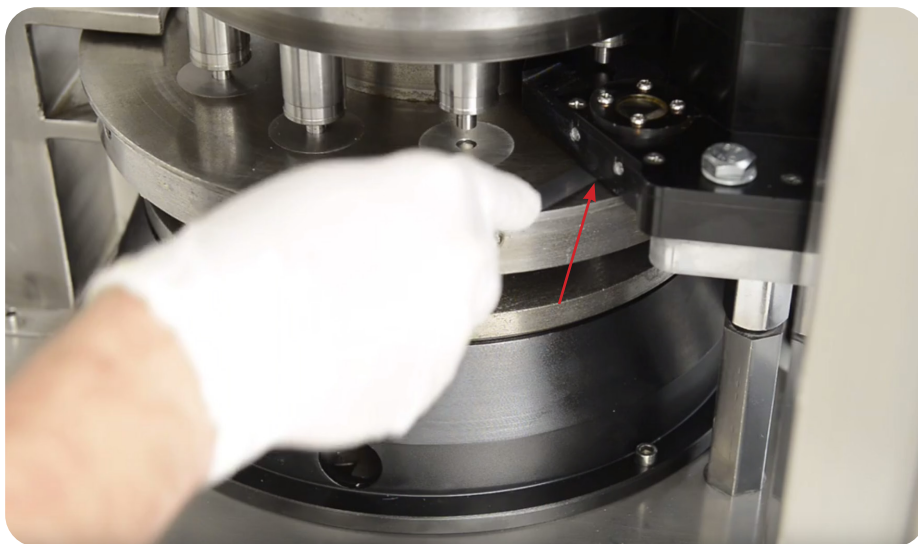

9. Adjust the Force Feeder Scraper so that it is flush against the Die Table.
8. Adjust the Take-Off Blade's distance from the Die Table so that it is $\frac{1}{3}$ of the tablet's height.
9. Tighten the Force Feeder's bolts.
10. Reinsert the Hopper to Force Feeder Connecting Pipe and the Hopper into the Force Feeder.
11. Tighten the Powder Shutoff Gate's bolt.

Force Feeder Speed

There is a variable speed control on the lefthand side of the RTP 10i®'s console to adjust the Force Feeder's speed. The Force Feeder's speed can be increased to address any flow issues with the powder.

Tools and Materials Needed

- Disposable latex/rubber gloves (for food grade products and to protect hands from grease)
- Hairnet and/or beard net (food grade products only)
- Sterile shoe covers (food grade products only)



WARNING: To prevent any potential personal injury, unplug the RTP 10i® from the electrical outlet.

Instructions

Note: Wear latex/rubber gloves (and appropriate food grade attire if applicable) during this process.

1. Ensure that the speed control switch is in the START position.
2. Rotate the speed control dial to adjust the Force Feeder's speed.
 - 2.1 Note: To increase the speed, turn the dial clockwise. To decrease the speed, turn the dial counterclockwise.



Tablet Thickness

Sometimes you will need to adjust the tablets' thickness so that the pressure level relative to the fill is high, which results in creating a solid tablet.

Tools and Materials Needed

- Disposable latex/rubber gloves (for food grade products and to protect hands from grease)
- Hairnet and/or beard net (food grade products only)
- Sterile shoe covers (food grade products only)



WARNING: To prevent any potential personal injury, unplug the RTP 10i® from the electrical outlet.

Instructions

Note: Wear latex/rubber gloves (and appropriate food grade attire if applicable) during this process.

1. Produce test tablets to determine how the machine should be adjusted.
2. Turn the leftmost most innerknob counterclockwise to unlock the pressure adjustment knob.
3. Rotate the leftmost knob on the console to change the tablet thickness.
3.1 Note: To make tablets thinner rotate the knob counterclockwise (increase punch pressure). To make tablets thicker, rotate the knob clockwise (decrease punch pressure).
4. Turn the leftmost innerknob clockwise to lock the pressure adjustment knob.



CAUTION: If the punch pressure is increased too much, the machine will automatically cut off and show an error message on the display. Simply decrease the punch pressure to get the machine running again.

Pre-Pressure Thickness

The pre-pressure thickness could be adjusted in the event that ejection forces are exceedingly high and it needs to be reduced, or it needs to be increased to help with air elimination in powder.

Tools and Materials Needed

- Disposable latex/rubber gloves (for food grade products and to protect hands from grease)
- Hairnet and/or beard net (food grade products only)
- Sterile shoe covers (food grade products only)



WARNING: To prevent any potential personal injury, unplug the RTP 10i® from the electrical outlet.

Instructions

Note: Wear latex/rubber gloves (and appropriate food grade attire if applicable) during this process.

1. Produce test tablets to determine how the machine should be adjusted.
2. Turn the middle innerknob counterclockwise to unlock the pre-pressure adjustment knob.
3. Rotate the middle knob on the console to change the pre-pressure thickness.
3.1 Note: To make tablets thinner rotate the knob counterclockwise (increase punch pressure). To make tablets thicker, rotate the knob clockwise (decrease punch pressure).
4. Turn the middle innerknob clockwise to lock the pre-pressure adjustment knob.



Oil Flow

If black spots are appearing on the tablets, it is due to over-lubrication of the machine, and oil cups or billows can be used to reduce the black spots. Tight Upper Punches and Lower Punches can be an indication of not enough oil. Adjusting the flow of the RTP 10i®'s oil wick well (located at the top of the machine) can help with these lubrication issues.

Tools and Materials Needed

- Disposable latex/rubber gloves (for food grade products and to protect hands from grease)
- Hairnet and/or beard net (food grade products only)
- Sterile shoe covers (food grade products only)



WARNING: To prevent any potential personal injury, unplug the RTP 10i® from the electrical outlet.

Instructions

Note: Wear latex/rubber gloves (and appropriate food grade attire if applicable) during this process.

1. Raise the oil wick's attachment in the upward position.
2. Rotate the adjustment to increase/decrease oil flow.

2.1 Note: Rotate the adjustment counterclockwise to increase the oil flow. Rotate the adjustment clockwise to decrease the oil flow.



Upper Roller Cam Penetration Adjustment

The Upper Punches' penetration can be adjusted by moving the Upper Roller Cam up or down. This could be done in response to capping in tablets or excessive ejection forces.

Tools and Materials Needed

- Wrench set
- Crosshead screwdriver
- Disposable latex/rubber gloves (for food grade products and to protect hands from grease)
- Hairnet and/or beard net (food grade products only)
- Sterile shoe covers (food grade products only)



WARNING: To prevent any potential personal injury, unplug the RTP 10i® from the electrical outlet.

Instructions

Note: Wear latex/rubber gloves (and appropriate food grade attire if applicable) during this process.

1. Raise each of the Perspex Casing's doors and lock them into an upward position.
2. Take off the Upper Roller Cam's cover with a crosshead screwdriver.
3. Loosen the Upper Roller Cam's bolt with a wrench.



4. Rotate the Upper Roller Cam to adjust the punch penetration.
 - 4.1 Note: Rotate clockwise to increase punch penetration and counterclockwise to decrease punch penetration.

Powder Flow

If there is an overflow of powder or if the formulation is not moving fast enough, there is a flow adjustment panel in the Hopper to address any flow issues.

To watch a video of powder flow adjustment, go to <https://www.lfatabletpresses.com/rtp10i-adjusting-formulation-flow>

Tools and Materials Needed

- Disposable latex/rubber gloves (for food grade products and to protect hands from grease)
- Hairnet and/or beard net (food grade products only)
- Sterile shoe covers (food grade products only)



WARNING: To prevent any potential personal injury, unplug the RTP 10i® from the electrical outlet.

Instructions

Note: Wear latex/rubber gloves (and appropriate food grade attire if applicable) during this process.

1. Raise each of the Perspex Casing's doors and lock them into an upward position.
2. Rotate the flow adjuster to change the powder flow.

2.1 Note: Turn the flow adjuster clockwise to decrease the amount of powder flowing into the Force Feeder; completely tightening the flow adjuster will stop all flow. Turn the flow adjuster counterclockwise to increase the amount of powder flowing into the Force Feeder.



Maintenance

To ensure that the RTP 10i® will have a long operational life, maintenance is essential. This section includes methods for replacing parts, troubleshooting solutions, and how often to grease and clean your machines to keep its performance optimal.

General Maintenance Prescriptions

- Use the maintenance checklist (found in the Appendix) before, during, and after machine operation.
- Make sure all grease points are maintained and regularly lubricated.
- Use an appropriate amount of lubricant. Excess grease can drip into the tablets as they are formed.
- Before reassembling the machine after cleaning, make sure that the parts are dried and oiled.
- Constantly check for any loose nuts and/or screws before, during, and after machine operation.
- If the machine is not used for more than a week, place the Tooling in an air-tight container and cover in lubricant.

Lubrication

Regularly greasing your machine is vital to prolonging its operational life. Parts that are not greased properly can make the machine seize up and cause major problems later. LFA recommends maintaining a lubrication schedule for your RTP 10i®, which can be found in this section.

Tools and Materials Needed

- Grease gun
- NLGI Grade 1 and Grade 2 grease
- SAE 90 or NSF approved equivalent
- SAE 10 oil
- Set of metric Allen keys with ball ends
- Disposable latex/rubber gloves (for food grade products and to protect hands from grease)
- Hairnet and/or beard net (food grade products only)
- Sterile shoe covers (food grade products only)



WARNING: To prevent any potential personal injury, unplug the RTP 10i® from the electrical outlet.

Instructions

Note: Wear latex/rubber gloves (and appropriate food grade attire if applicable) during this process.

1. Raise each of the Perspex Casing's doors and lock them into an upward position.

2. Remove the Upper Punches and Lower Punches.

2.1 For additional assistance, please refer to the Tooling replacement instructions on page 33.

3. Lubricate the heads of the Upper Punches and Lower Punches with NLGI Grade 1 grease.

4. Lubricate the barrels of the Upper Punches and Lower Punches with SAE 10 oil.



5. Apply SAE 90 or food grade equivalent to the wick of the Upper Cam's oil well with a grease gun.



6. Lubricate the Upper Roller Cam's grease nipple with NLGI Grade 2 grease.



7. Pull off the righthand side panel door.

8. Lubricate the Lower Roller Cam's grease nipple with NLGI Grade 2 grease.



Lubrication Schedule

LFA recommends the following RTP 10i® parts to be lubricated according to the following frequency:

Part	Location	Image	Frequency	Type of Lubricant
Main Worm Gear	Mounted above the Motor in the lower section of the press		Visually inspect through the eye glass and apply when dry (approximately every 6 months).	WA 460 Oil (0.55 L)
Upper Roller Cam	Oil well with wick on the top of the machine		Visually inspect and apply when dry.	SAE 90 or NSF food grade equivalent
Upper Cam Shaft	Grease nipple located in the center of the Upper Roller Cam		Apply every 100 hours/ once per week.	NLGI Grade 2
Lower Cam Shaft	Grease nipple located in the center of the Lower Roller Cam		Apply every 100 hours/ once per week.	NLGI Grade 2
Tooling Heads	Heads of Upper Punches and Lower Punches		Inspect and apply when dry.	NLGI Grade 1
Tooling	Air-tight container		Cover and store in oil after cleaning.	Mineral oil
Tooling Barrels	The main shaft of the Upper Punches and Lower Punches		Every time Tooling is installed in the press.	SAE 10

Dismantling for Repair and Replacement

Eventually due to wear and tear, some parts of the RTP 10i® will need to be removed for repair and replacement. To prevent any delays in your tablet production, it is best practice to keep extra parts just in case.

To buy a RTP 10i® part replacement, simply go to <https://www.lfatabletpresses.com/products/pill-press-machine-spare-parts/rtp-10i-parts>

Warranty

To access LFA's warranty policy, go to <https://www.lfatabletpresses.com/warranty>
If your part is eligible for warranty, have your part's serial number on hand and please contact LFA:

UK

Phone

+44 (0) 0345 165 20 25

Email

sales@lfamachines.com

USA

Phone

(682) 312-0309

Email

sales.usa@lfamachines.com



WARNING: To prevent any potential personal injury, ALWAYS unplug the RTP 10i® from the electrical outlet when replacing parts.

Wear Parts and Causes of Damage

Wear Part	Cause of Damage
Tooling	The Tooling can become chipped or broken. Lead times for a new set of Tooling can take as long as 6-8 weeks, so LFA recommends having a spare set or two.
Force Feeder	On the RTP 10i®, the Force Feeder is used to spread the powder over the Die Table and into the Die bores. There is a brass wear part located on the bottom of the Force Feeder. It protects the Turret/Die Table and the Tooling. If this part is damaged by a Die sitting above the Die Table, it is possible to refinish it using a flat stone, some oil, and 3000 grit sandpaper.
Force Feeder Scraper and Take-Off Blade	The Force Feeder Scraper is used to take off the excess powder from the Die Table after the Dosing Cam has forced out the powder. The Take-Off Blade is used to aid in tablet ejection. These parts can become damaged if a Die is protruding from the Die Table or if a Lower Punch jumps up from the Dosing Cam. To reduce waste, these parts will need to be replaced if damaged.
Ejection Cam	The Ejection Cam ejects the tablets at the correct moment in the Turret's cycle. This part is not able to be tuned and is fixed in place. Over time this part can wear, and the tablet's ejection point can get lower until they are not ejecting correctly from the Die bores. The three main causes of this are: 1) tight Lower Punches due to buildup of excess fines in powder, 2) high ejection forces that are caused by sticky powders clinging to the Die bore's wall, and 3) powder that mixes with oil/grease, which creates a sandpaper effect on the Ejection Cam.
Fill Cam	The Fill Cam pulls down the Lower Punches to fill the Die bores with powder. This part is built from brass and is designed to wear to protect the Tooling and the press. The main causes of a worn Fill Cam are: 1) tight Lower Punches due to buildup of excess fines in powder, 2) use of incorrect Tooling with the wrong head profile, and 3) powder that mixes with oil/grease, which creates a sandpaper effect on the Fill Cam.
Dosing Cam	The Dosing Cam is used to calibrate the press to produce the desired tablet weight. This is done by pushing excess powder out of the Die bore after it has been filled. The main causes of a worn Dosing Cam are: 1) Tight Lower Punches due to buildup of excess fines in powder, 2) use of incorrect Tooling with the wrong head profile, and 3) powder that mixes with oil/grease, which creates a sandpaper effect on the Dosing Cam.
Upper/Lower Roller Cams	The Roller Cams apply all the pressure onto the Tooling. If these become worn, it can cause damage to the tops of the Tooling and affect tablet hardness and consistency. This is predominantly caused by general wear and, in some cases, excess punch pressure being applied.
Upper/Lower Pre-Pressure Roller Cams	The Pre-Pressure Roller Cams apply a small amount of pressure to the Tooling to remove excess air from the Die bores and powder. If these become worn it can cause damage to the tops of the Tooling, which can affect tablet hardness and consistency.

Tooling

If you want to change the shape and diameter of the tablet, or if any of the Upper Punches, Lower Punches, and/or Dies you currently have are damaged, it is necessary to change the Tooling.

To watch a video of an RTP 10i® Tooling change, go to <https://www.lfatabletpresses.com/rtp10i-tooling-change>

To buy new Tooling from LFA, simply go to <https://www.lfatabletpresses.com/products/tablet-press-tooling>

Tools and Materials Needed

- Set of metric Allen keys with ball ends
- Wrench set
- Crosshead screwdriver
- New Tooling (Upper Punches, Dies, and Lower Punches)
- Toolkit (comes with machine)
- Lubricant (NSF approved for food grade products)
- Heavy rubber mallet
- Disposable latex/rubber gloves (for food grade products and to protect hands from grease)
- Hairnet and/or beard net (food grade products only)
- Sterile shoe covers (food grade products only)



WARNING: To prevent any potential personal injury, ALWAYS unplug the RTP 10i® from the electrical outlet when replacing parts.

Instructions

Note: Wear latex/rubber gloves (and appropriate food grade attire if applicable) during this process.

Remove the Old Tooling

1. Raise each of the Perspex Casing's doors and lock them into an upward position.
2. Unscrew the Hopper to Force Feeder Connecting Pipe's bolt by hand and remove the Hopper.



3. Remove the Hopper to Force Feeder Connecting Pipe.
4. Unscrew and remove the Force Feeder's 17 mm bolts with a wrench or by hand.
5. Pull up the Force Feeder and remove it from the RTP 10i®.



6. Remove the entire Upper Tooling Shroud with a crosshead screwdriver.



7. Remove the Upper Tracking Key with an Allen key.



8. Pull off the upper righthand side panel door and pull out the Hand Wheel's handle.
9. Rotate the Hand Wheel until an Upper Punch is where the Upper Tracking Key was previously.
10. Pull the Upper Punch upwards to remove it from the Turret.
11. Repeat steps 9-10 until all Upper Punches are removed.

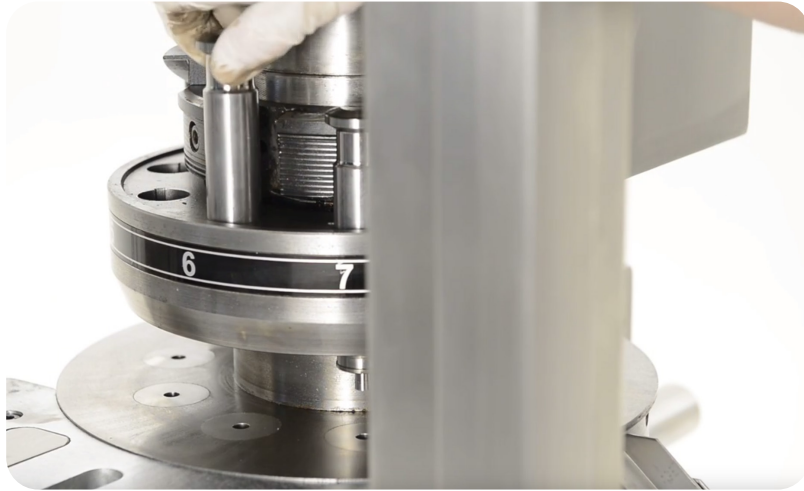

12. Remove the Lower Tooling Shroud with an Allen key.

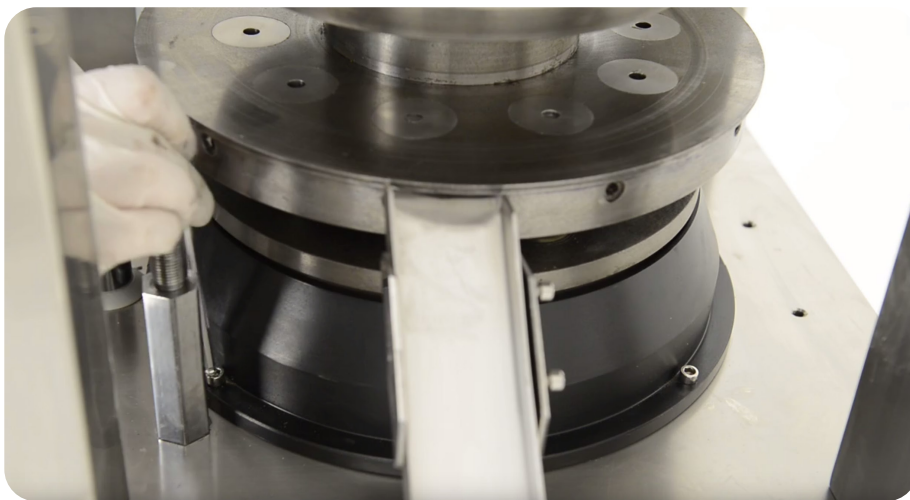

13. Push up the the Lower Punch Retaining Puck underneath the Lower Punches and remove it from the RTP 10i®.



14. Rotate the Hand Wheel until a Lower Punch is aligned with where the Lower Punch Retaining Puck was previously.
15. Gently pull on the Lower Punch's head through the hole.
 - 15.1 Note: Be sure to have a firm hold on the Lower Punch so that it does not fall and become damaged.
16. Repeat steps 14-15 until all Lower Punches are removed.

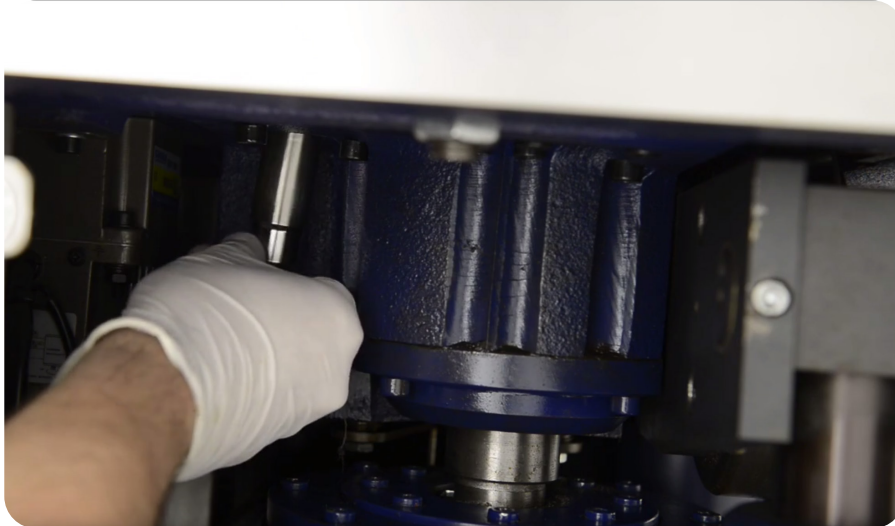

17. Rotate the Hand Wheel until a Die is aligned with where the Lower Punch Retaining Puck was previously.
18. Remove the Die's bolt with an Allen key.

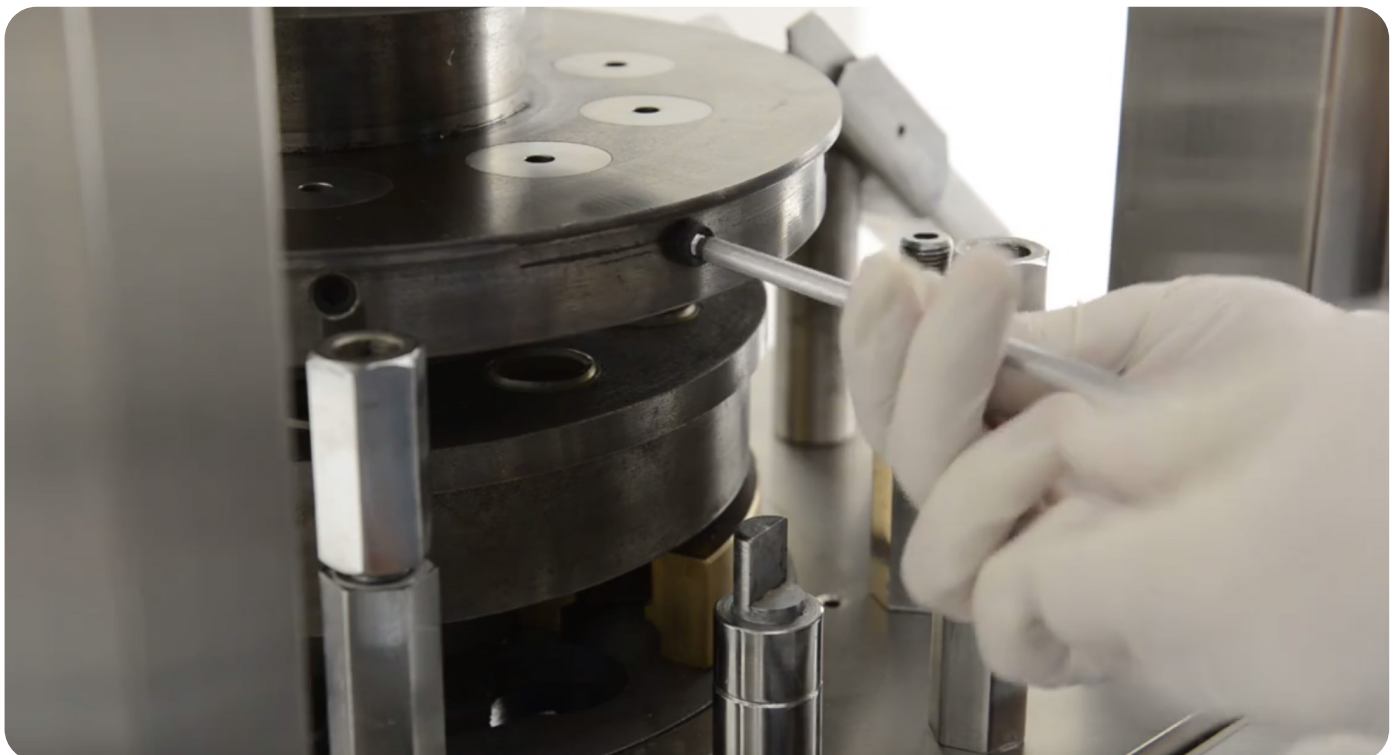

19. Insert the Die Removal Bar up through the hole where the Lower Punch Retaining Puck was previously.

20. Tap the Die with the Die Removal Bar until it pops up from the Turret.

20.1 Note: If Die is difficult to remove, tap the end of the Die Removal Bar with a rubber mallet.

21. Repeat steps 17-20 until all Dies are removed.

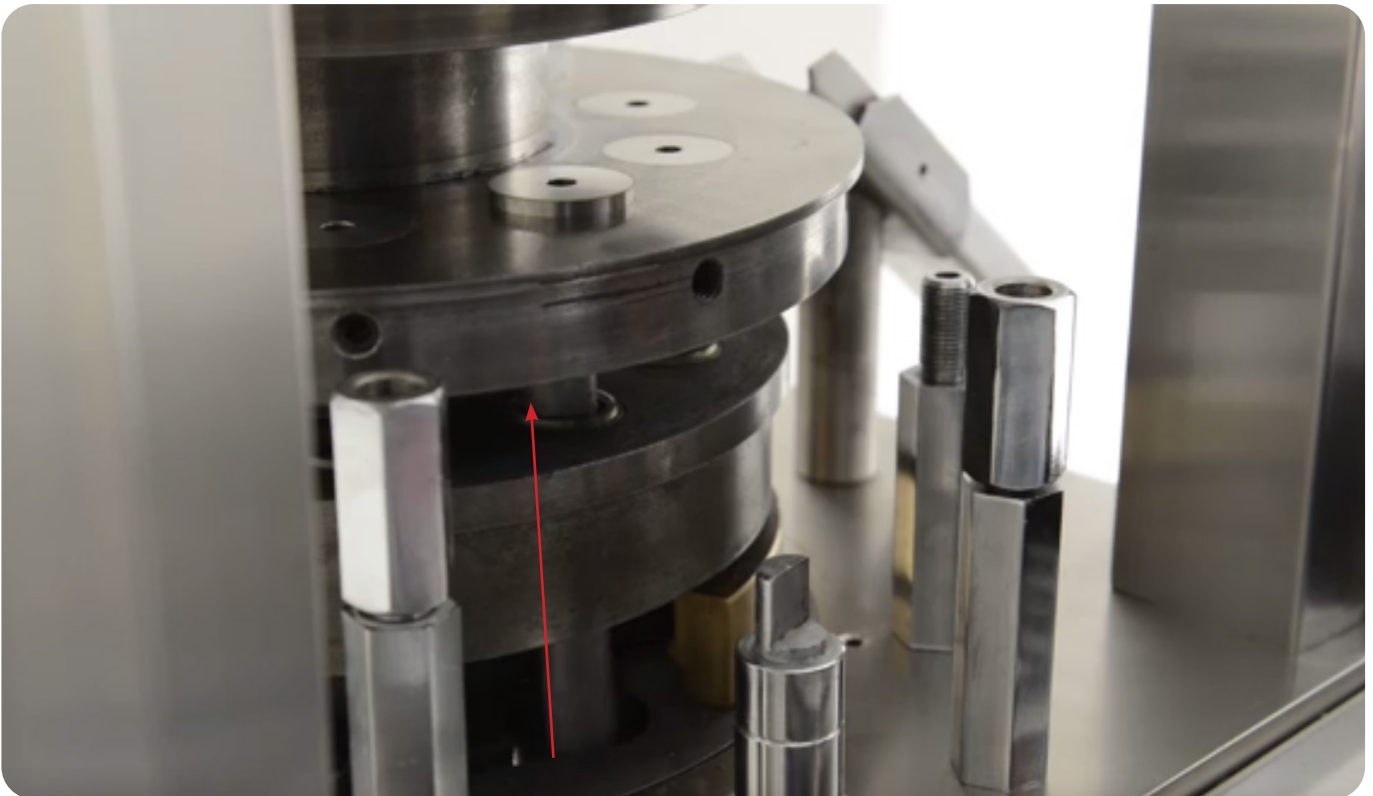
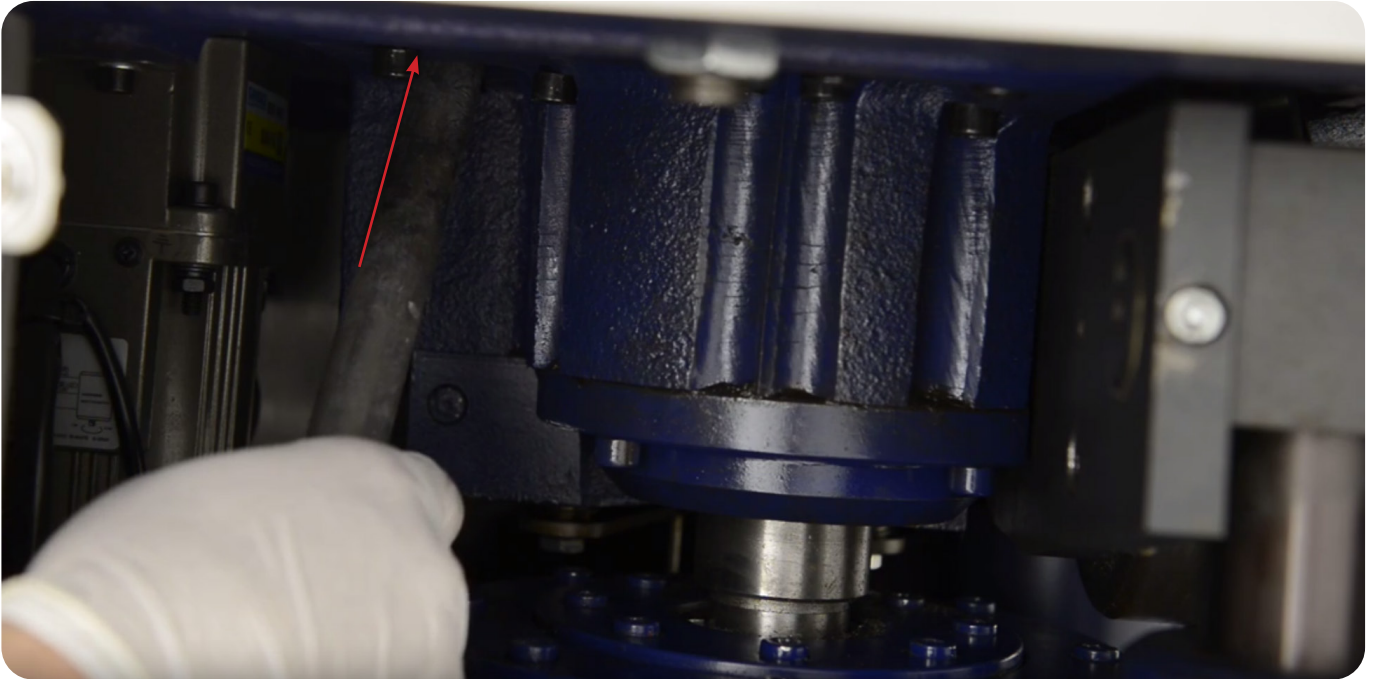

Note: To help ensure that the Dies are inserted correctly, LFA recommends using an Insertion Ring. You can order the Die Seat Cleaner and Insertion Ring on our website at <https://www.lfatabletpresses.com/die-seat-cleaner-insertion-ring>



Replace the Tooling

22. Position the new Die on the Turret.

22.1 Note: Place a bit of grease around the new Die's sides to make insertion easier.

23. Insert the Die Installation Bar through the Upper Punch's hole and over the new Die.

24. Tap the Die Installation Bar with a rubber mallet until the new Die is inserted into the Turret.

24.1 Note: Make sure that the new Die is flush with the Turret.

24.2 Note: The photo below displays installing the Die with the Insertion Ring.

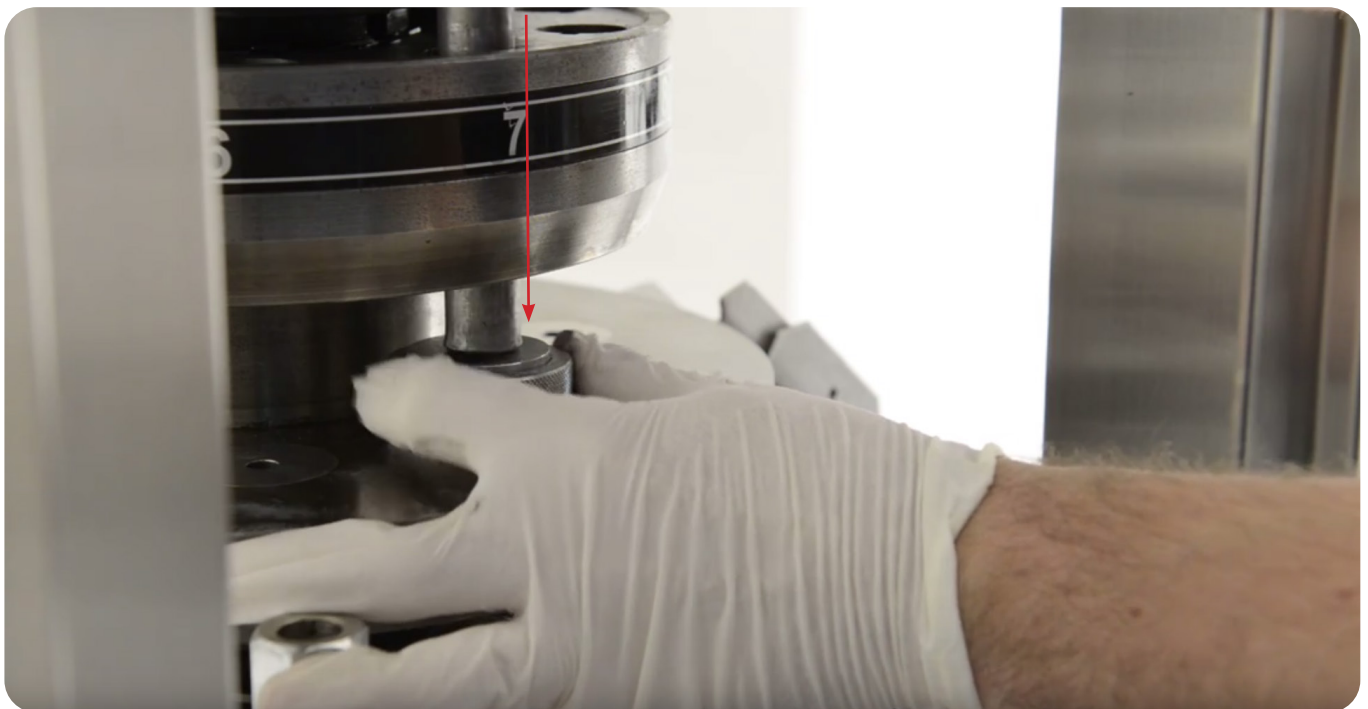

25. Reinsert the Die's bolt in the Turret and tighten with an Allen key.

25.1 Note: The bolt should be tightened to around 16 lbs/ft.

26. Rotate the Hand Wheel until the next new Die can be inserted.

27. Repeat steps 22-26 until all the new Dies are secured in the Turret.

28. Insert a new Lower Punch up through the Lower Punch Retaining Puck's hole and into the new Die's bore.

28.1 Note: Lubricate the barrel of the Lower Punch.

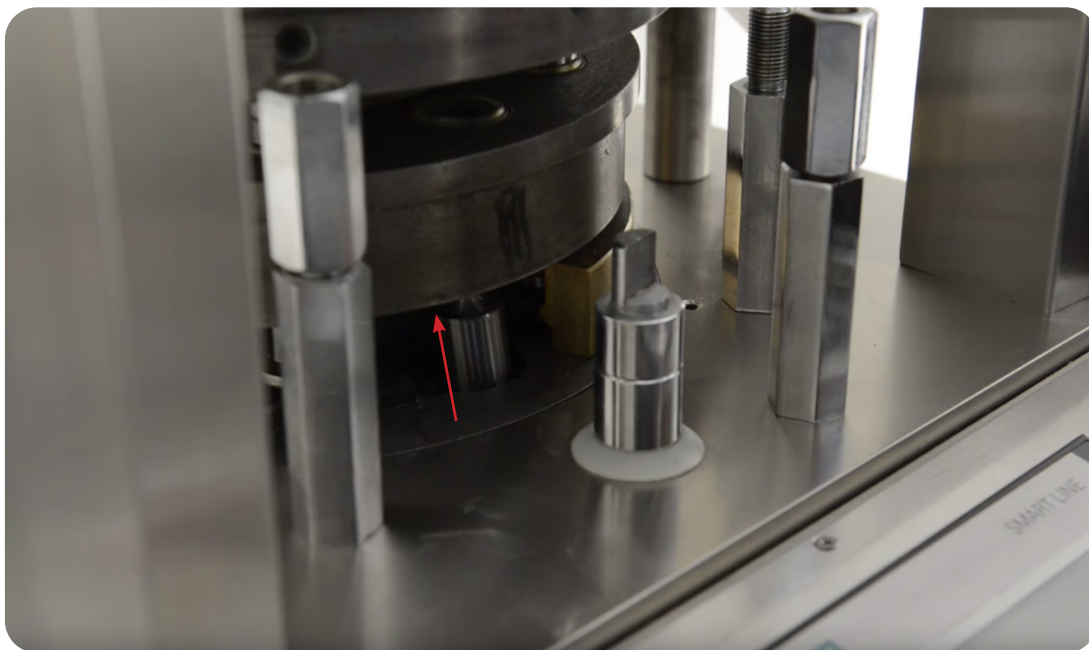

29. Rotate the Hand Wheel until the next new Lower Punch can be inserted.

30. Repeat steps 28-29 until all the new Lower Punches are inserted into the Turret.

30.1 Note: Manually turn the RTP 10i® Turret for a couple of rotations to ensure that the new Lower Punches are situated correctly.

31. Reinsert the Lower Punch Retaining Puck with the beveled side facing up.

31.1 Note: Make sure that the Lower Punch Retaining Puck is flat in the hole and not sticking up.

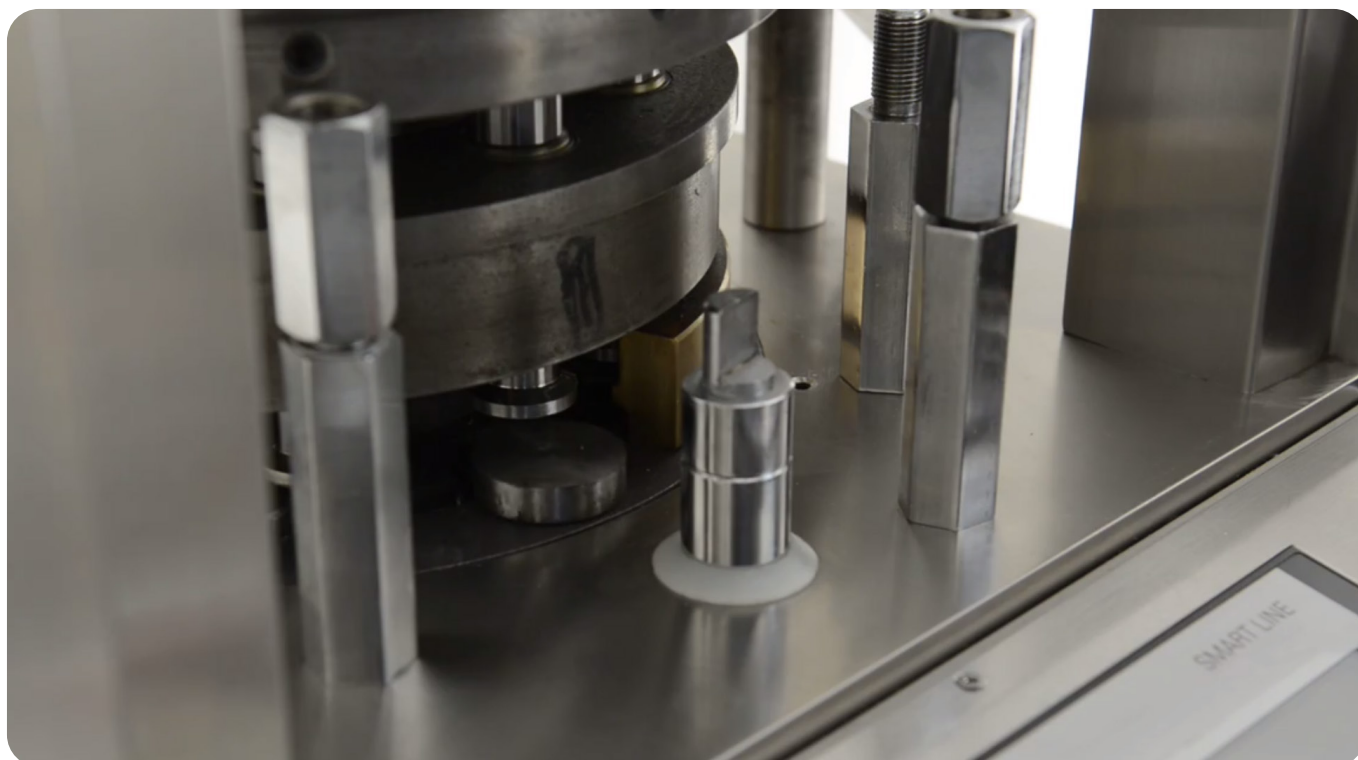

32. Insert a new Upper Punch through the top of the Turret.
32.1 Note: Lubricate the barrel of the Upper Punch.
33. Place the new Upper Punch's head on the Upper Tracking.
33.1 Note: Be sure that the new Upper Punch's head is above the Upper Tracking to prevent damage.
34. Rotate the Hand Wheel until the next new Upper Punch can be inserted.
35. Repeat steps 32-34 until all the new Upper Punches are inserted into the Turret.
35.1 Note: Manually turn the RTP 10i® Turret for a couple of rotations to ensure that the new Upper Punches are situated correctly.
36. Resecure the Upper Tracking Key with an Allen key.



- 37. Reassemble the Lower Tooling Shroud and insert it back on the RTP 10i® with an Allen key.
- 38. Resecure the Upper Tooling Shroud back on the RTP 10i® with a crosshead screwdriver.
- 39. Place the Force Feeder on the RTP 10i® base's key and align it with the bolts' holes.

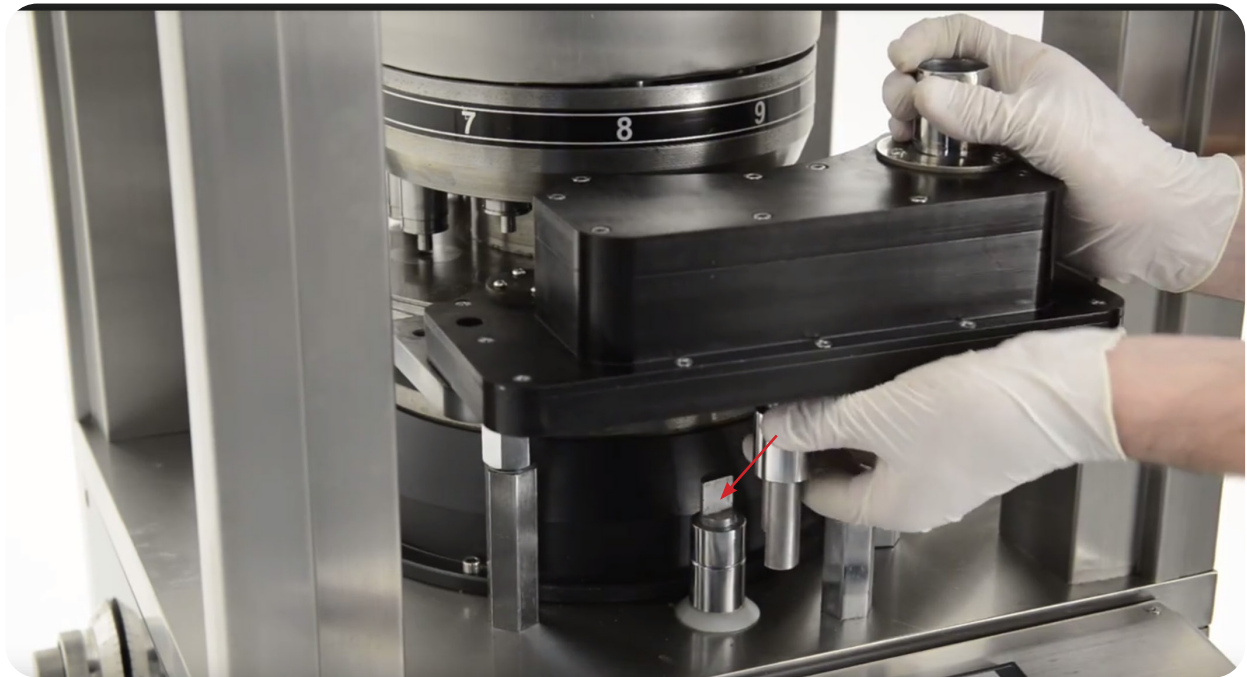

- 40. Resecure the bolt onto the Hopper to Force Feeder Connecting Pipe.
- 41. Lower all the Perspex Casing's doors.



Force Feeder Wear Plate

The Force Feeder channels the dry materials into the Die bores. This part has a brass plate designed to wear to avoid damaging the Tooling and/or Turret, so it may need to be replaced.

Tools and Materials Needed

- Crosshead screwdriver
- Wrench set
- New Force Feeder Wear Plate part
- Disposable latex/rubber gloves (for food grade products and to protect hands from grease)
- Hairnet and/or beard net (food grade products only)
- Sterile shoe covers (food grade products only)



WARNING: To prevent any potential personal injury, ALWAYS unplug the RTP 10i® from the electrical outlet when replacing parts.

Instructions

Note: Wear latex/rubber gloves (and appropriate food grade attire if applicable) during this process.

Remove the Force Feeder Wear Plate

1. Raise each of the Perspex Casing's doors and lock them into an upward position.
2. Unscrew the Powder Shutoff Gate's bolt by hand and remove the Hopper.
3. Remove the Hopper to Force Feeder Connecting Pipe.



4. Unscrew and remove the Force Feeder's 17 mm bolts with a wrench or by hand.
5. Pull up the Force Feeder and remove it from the RTP 10i®.



6. Remove the Force Feeder Wear plate with a crosshead screwdriver.

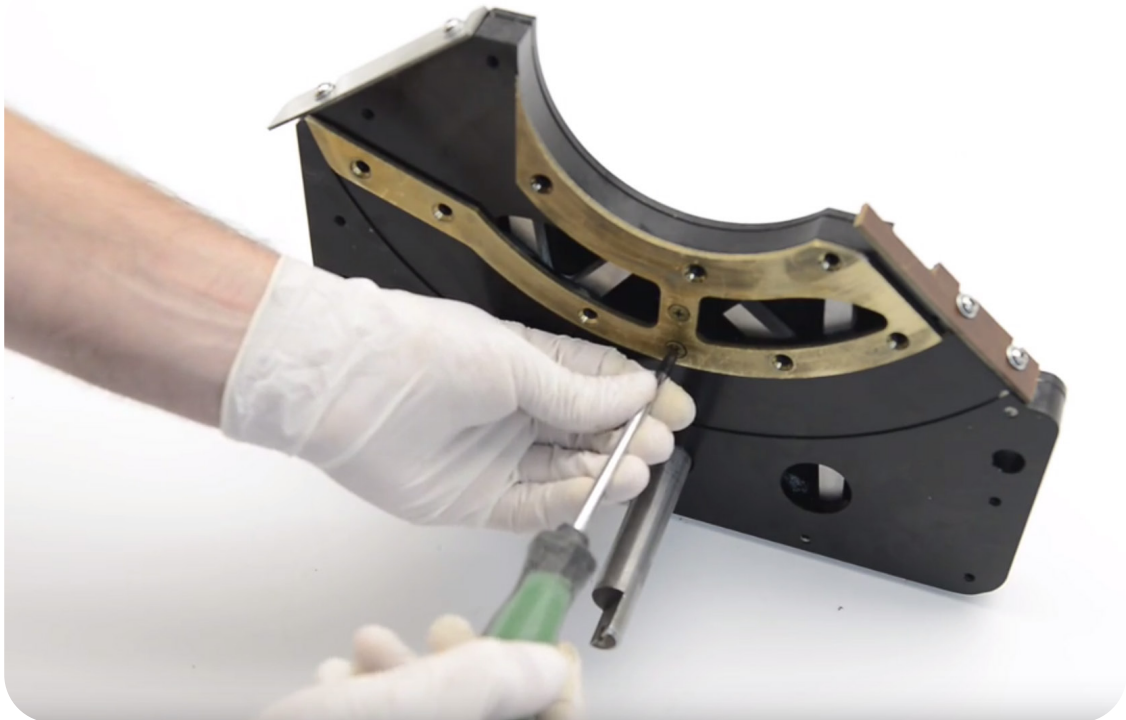

Replace the Force Feeder Wear Plate

7. Attach the new Force Feeder Wear Plate to the Force Feeder with a crosshead screwdriver.
8. Place the Force Feeder on the RTP 10i® base's key and align it with the bolts' holes.



9. Screw in the Force Feeder's 17 mm bolts.

9.1 Note: Please refer to the Force Feeder Height adjustment instructions on page 20 for calibration or watch the following video: <https://www.lfatabletpresses.com/rtp10i-force-feeder-calibration>

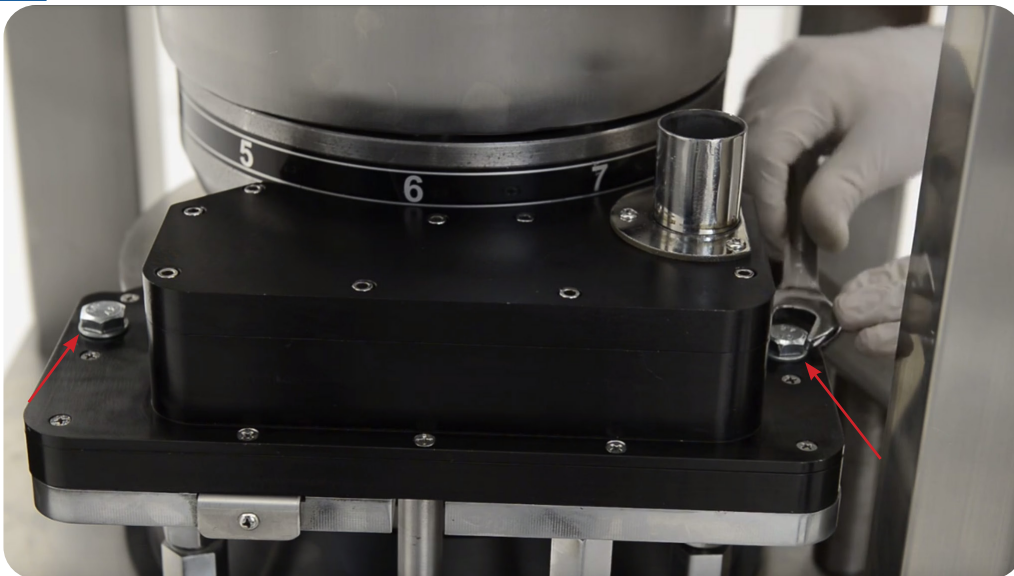

10. Reinsert the Hopper to Force Feeder Connecting Pipe and Hopper and secure the Powder Shutoff Gate's bolt.
11. Lower all the Perspex Casing's doors.

Take-Off Blade and Force Feeder Scraper

The Take-Off Blade and Force Feeder Scraper are attached to the Force Feeder. They help keep the powder flowing into the Dies' bores and aid in tablet ejection.

Tools and Materials Needed

- Crosshead screwdriver
- Wrench set
- New Take-Off Blade and Scraper part
- Disposable latex/rubber gloves (for food grade products and to protect hands from grease)
- Hairnet and/or beard net (food grade products only)
- Sterile shoe covers (food grade products only)



WARNING: To prevent any potential personal injury, ALWAYS unplug the RTP 10i® from the electrical outlet when replacing parts.

Instructions

Note: Wear latex/rubber gloves (and appropriate food grade attire if applicable) during this process.

Remove the Take-Off Blade and Force Feeder Scraper

1. Raise each of the Perspex Casing's doors and lock them into an upward position.
2. Unscrew the Hopper to Force Feeder Connecting Pipe's bolt by hand and remove the Hopper.
3. Remove the Hopper to Force Feeder Connecting Pipe.



4. Unscrew and remove the Force Feeder's 17 mm bolts with a wrench or by hand.
5. Pull up the Force Feeder and remove it from the RTP 10i®.



6. Remove the Force Feeder Scraper with a crosshead screwdriver.

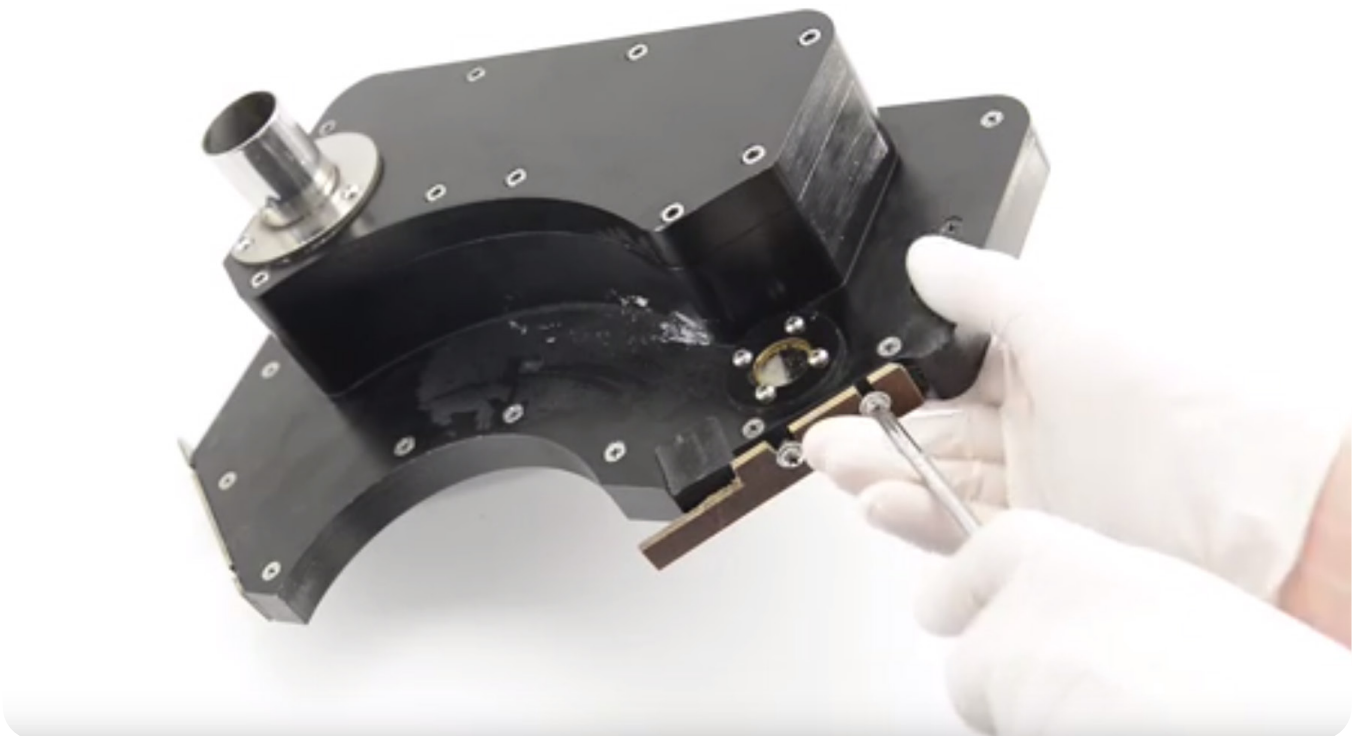

7. Remove the Take-Off Blade from the Force Feeder with a crosshead screwdriver.

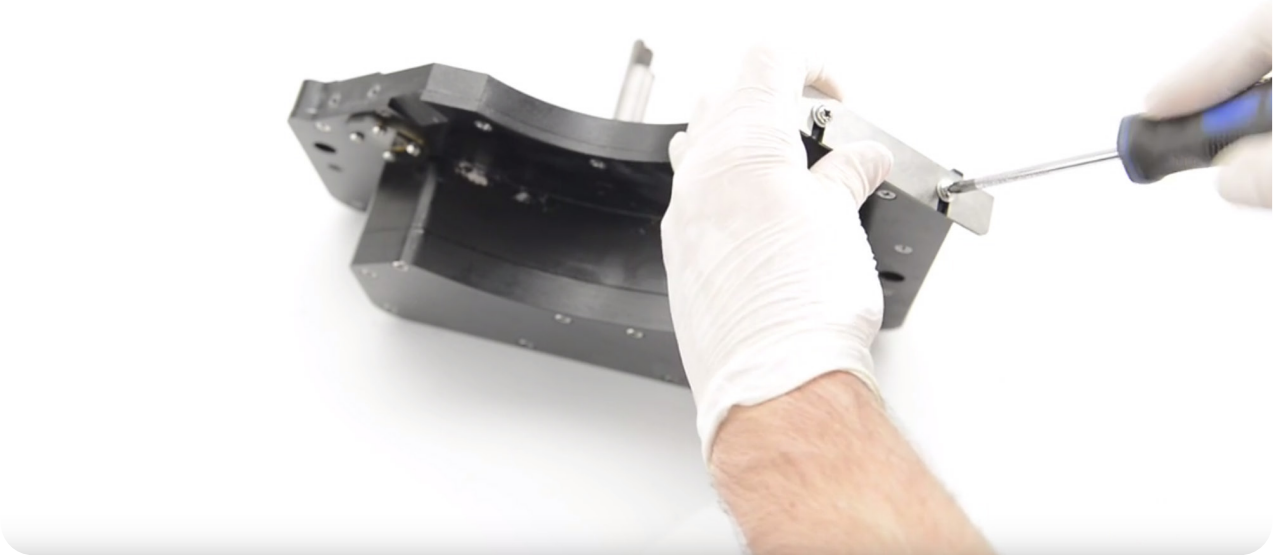

Replace the Take-Off Blade and Force Feeder Scraper

8. Loosely attach the Take-Off Blade to the Force Feeder.

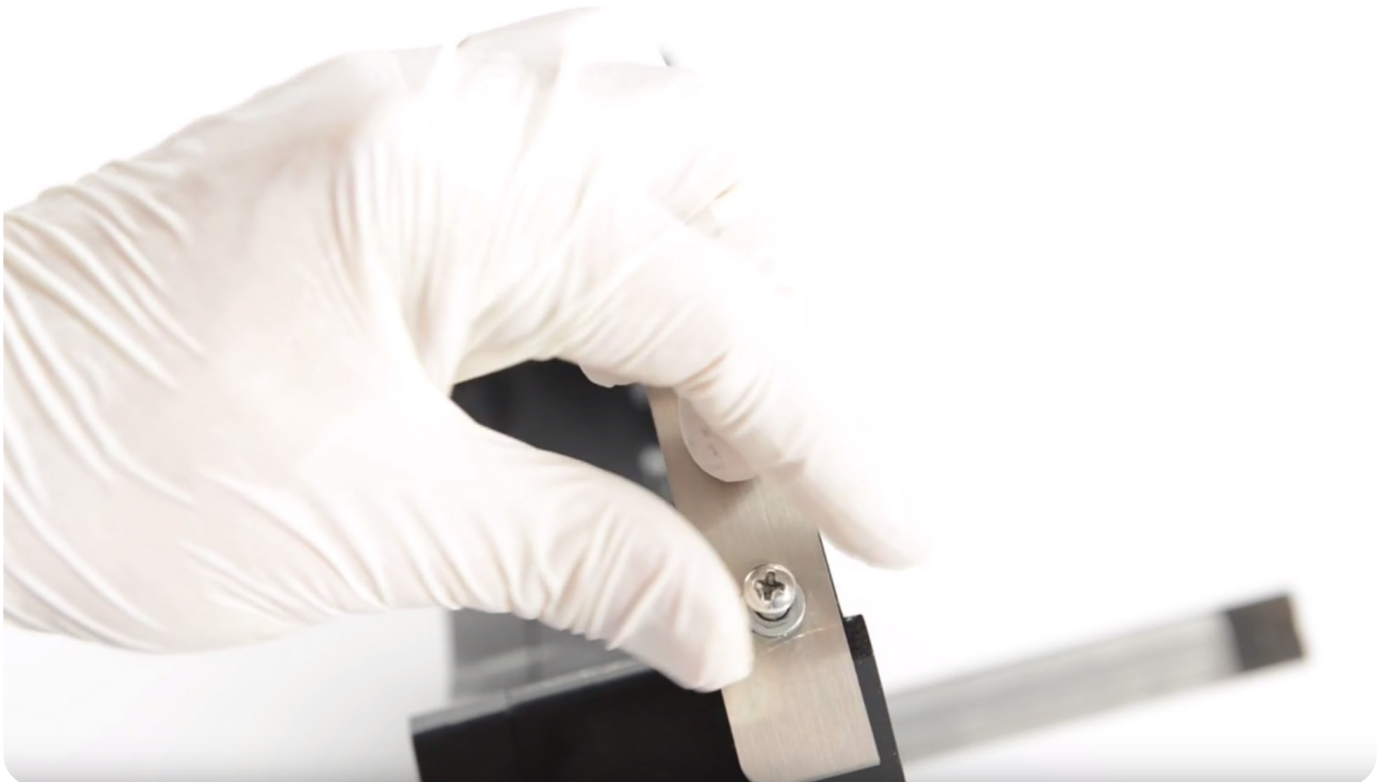

9. Loosely attach the Force Feeder Scraper to the Force Feeder.

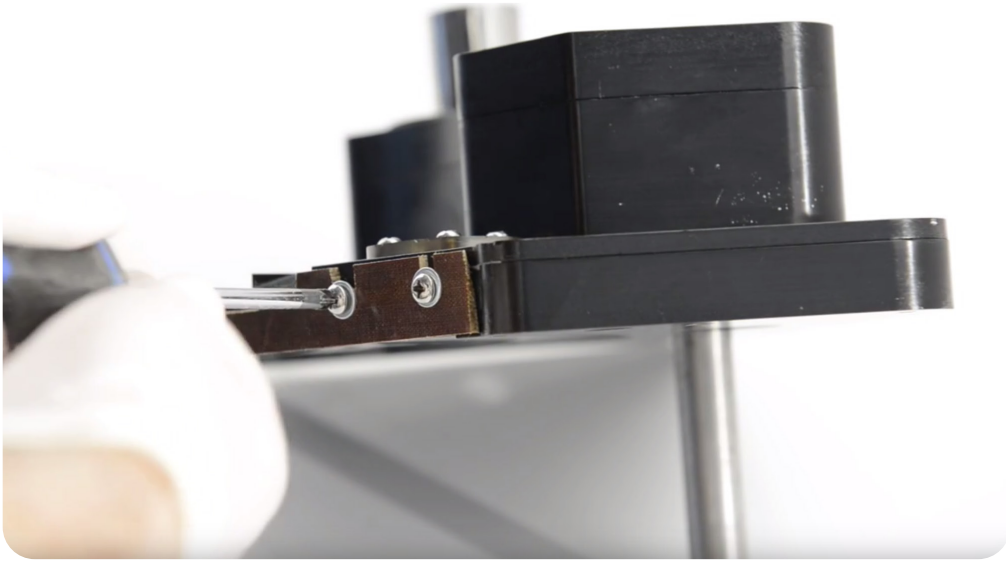

10. Place the Force Feeder on the RTP 10i® base's key and align it with the bolts' holes.



11. Screw in the Force Feeder's bolts.

11.1 Note: Please refer to the Force Feeder Height adjustment instructions on page 20 for calibration or watch the following video: <https://www.lfatabletpresses.com/rtp10i-force-feeder-calibration>

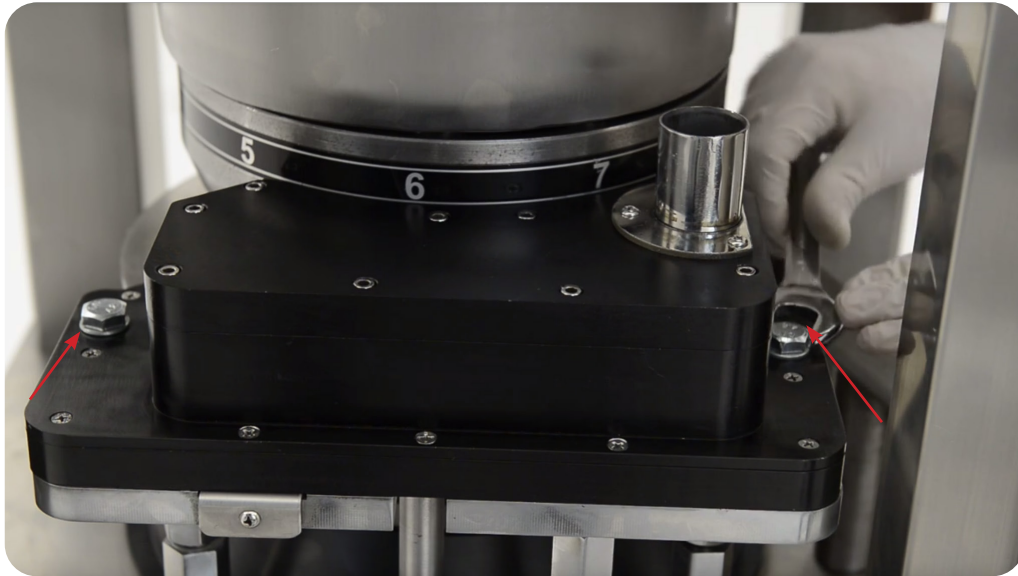

12. Adjust the Force Feeder Scraper so that it is flush against the Die Table.

13. Adjust the Take-Off Blade's distance from the Die Table so that it is $\frac{1}{3}$ of the tablet's height.

14. Resecure the Hopper to the Force Feeder with the Hopper to Force Feeder Connecting Pipe's bolt.

1. Lower all the Perspex Casing's doors.

Adjustment Knobs

The adjustment knobs are located on the lefthand side of the RTP 10i® and control the tablet's thickness and weight as well as the Pre-Pressure Roller Cam compression level.

Tools and Materials Needed

- New Adjustment Knob part
- Disposable latex/rubber gloves (for food grade products and to protect hands from grease)
- Hairnet and/or beard net (food grade products only)
- Sterile shoe covers (food grade products only)



WARNING: To prevent any potential personal injury, ALWAYS unplug the RTP 10i® from the electrical outlet when replacing parts.

Instructions

Note: Wear latex/rubber gloves (and appropriate food grade attire if applicable) during this process.

Remove the Adjustment Knob

1. Turn the inner knob counterclockwise until it disengages and remove it.



2. Pull off the Adjustment Knob from the RTP 10i®.



Replace the Adjustment Knob

3. Insert the new Adjustment Knob onto the keyed shaft.

3.1 Note: Ensure that the keyed shaft is in the upward position.



4. Rotate the inner knob clockwise until the new Adjustment Knob is secure.



Troubleshooting

Sometimes unavoidable issues will occur while operating the RTP 10i®. Fortunately, there are several methods to remedy these issues.

Common Machine/Part Issues

Symptom	Possible Cause	Possible Solution
Machine freezes or locks up	Grease point areas are dry.	Regularly oil and grease all the Grease Nipples and high friction areas.
	There is excess pressure.	Rotate the Pressure Knob on the lefthand side of machine counterclockwise.
	There is caking of powder in the machine.	Take apart the Turret and Tooling and clean.
Knocking sounds coming from machine	There is excess pressure.	Rotate the Pressure Knob on the lefthand side of the machine counterclockwise.
	The V Belt is loose.	Adjust the Motor Support Arm's nuts to tighten the V Belt.
	Parts may be loose.	Check the machine's parts and tighten as necessary.
	The Gearbox needs oil.	Check the Gearbox's oil gauge and lubricate as necessary.
Heavy resistance during production	The high friction areas are either unclean, locked, worn out, or not greased properly.	Apply grease to the Grease Nipple points and all high friction areas and/or clean the machine.
Excess machine vibration	The V Belt is worn.	Replace the V Belt.
	The machine has no anti-vibration pads or they are worn.	Place new anti-vibration pads on the bottom of the machine.
	Parts may be loose.	Check the machine's parts and tighten as necessary.
Excess powder waste	The dry materials are moving too fast.	Lower the rotation speed.
	The Force Feeder is too high or unlevelled.	Adjust the Force Feeder, Take-Off Blade, and Scraper accordingly.

Symptom	Possible Cause	Possible Solution
Inability to compact materials to tablet form	The Force Feeder is blocked and not enough materials are flowing out.	Check the Force Feeder for a potential clog.
	There is not enough pressure.	Rotate the Pressure Knob on the lefthand side of the machine clockwise.
	The Tooling is damaged.	Remove and replace the Tooling (all Upper Punches, Lower Punches, and Dies).
	There are flowing issues with the mix.	If the machine is able to make tablets with LFA's Firmapress [®] , then the problem is your mix. Adjust your formulation. If still an issue, contact LFA for support.

Common Tablet Issues

Symptom	Possible Cause	Possible Solution
Double tablets	Previous tablet did not eject correctly.	Remove the double tablet manually from the Die bore.
	Excess granular materials were placed in the Die, which prevented the ejection of the existing tablet.	Clean the Tooling to remove any excess granular materials and make sure that it is clean and completely dry.
Cracked or broken tablets	There are problems with the formulation of the granules and ingredients.	If the machine is able to make tablets with LFA's Firmapress [®] , then the problem is your mix. Adjust your formulation. If still an issue, contact LFA for support.
	The Force Feeder is not feeding enough material to be pressed in tablet form.	Adjust the Force Feeder, Take-Off Blade, and Scraper accordingly.
	There is excess pressure.	Please read our article on Capping at https://www.lfatabletpresses.com/articles/tablet-capping
Inconsistent Tablet Weight	Lower Punches are loose.	Check for loose Lower Punches and insert correctly if necessary.
	Not enough pressure is being exerted.	Rotate the Pressure Knob on the left side of the machine clockwise.
	There are flowing issues with the mix.	If the machine is able to make tablets with LFA's Firmapress [®] , then the problem is your mix. Adjust your formulation. If still an issue, contact LFA for support.
Soft tablets	There is too little punch pressure.	Rotate the Pressure Knob on the left side of the machine counterclockwise.
	There are flowing issues with the mix.	If the machine is able to make tablets with LFA's Firmapress [®] , then the problem is your mix. Adjust your formulation. If still an issue, contact LFA for support.
Uneven tablets	The Tooling is worn out.	Check the ingredients of your formula before you replace the Tooling.
Broken tablets during ejection	The Ejection Cam is dirty.	Take off the Turret and inspect Ejection Cam and clean if necessary.
	The Ejection Cam is worn.	Replace the Ejection Cam.

De-Jamming the RTP 10i[®]

There are several reasons why a RTP 10i[®] might jam such as:

- The fill depth is set too low and the pressure is set too high. At its highest punch pressure force, the machine will automatically cut off.
- There is a build up of powder inside the Force Feeder Adjustment Base Discharge Plate.

The methods that can fix a jammed RTP 10i[®] follow below:



WARNING: To prevent any potential personal injury, ALWAYS unplug the RTP 10i[®] before dejamming it.

Tools and Materials Needed

- Container for excess powder
- Crosshead screwdriver
- Disposable latex/rubber gloves (for food grade products and to protect hands from grease)
- Hairnet and/or beard net (food grade products only)
- Sterile shoe covers (food grade products only)

Instructions

Note: Wear latex/rubber gloves (and appropriate food grade attire if applicable) during this process.

Method 1: Lower the Punch Pressure

1. Rotate the lefthand knob on the console counterclockwise to its limit.
2. Rotate the middle knob on the console counterclockwise to its limit.
3. Rotate the righthand knob on the console counterclockwise to its limit.
4. Lift up the Hand Wheel's handle.
5. Turn the Hand Wheel clockwise until the machine turns over.

Method 1: Release the Excess Powder

1. Place a container underneath the Force Feeder Adjustment Base Discharge Plate.
2. Remove the Force Feeder Adjustment Base Discharge Plate's screw with a crosshead screwdriver.
3. Pull out the Force Feeder Adjustment Base Discharge Plate to release excess powder.
4. Reinsert the Force Feeder Adjustment Base Discharge Plate and secure its screw with a crosshead screwdriver.



Cleaning

During the RTP 10i®'s operation, excess powder will find its way into parts of the machine, particularly in the Tooling and Force Feeder. It is important to clean the RTP 10i® thoroughly to prevent rusting and cross contamination.

LFA recommends that the machine be cleaned after each operation.

Tools and Materials Needed

- Container for excess powder
- Cleaning brush
- Bagless vacuum
- Long wire pipe cleaner
- Toothbrush
- Cleaner (e.g. Member's Mark Commercial Lemon Fresh Disinfectant)
- Sanitizer (e.g. Member's Mark Commercial Sanitizer)
- Set of metric Allen keys with ball ends
- Crosshead screwdriver
- Flathead screwdriver
- Die Installation/Removal Bar from RTP 10i® Toolkit
- Disposable latex/rubber gloves
- Bowl of warm soapy water (nothing abrasive)
- Clean cloths
- Potable water
- Hairnet and/or beard net (food grade products only)
- Sterile shoe covers (food grade products only)



WARNING: To prevent any potential personal injury, ALWAYS unplug the RTP 10i® from the electrical outlet when replacing parts.

Instructions

Note: Wear latex/rubber gloves (and appropriate food grade attire if applicable) during this process.

Release Excess Powder

1. Place a container underneath the Force Feeder Adjustment Base Discharge Plate.
2. Remove the Force Feeder Adjustment Base Discharge Plate's screw with a crosshead screwdriver.



3. Pull out the Force Feeder Adjustment Base Discharge Plate to release excess powder.



4. Reinsert the Force Feeder Adjustment Base Discharge Plate and secure its screw with a crosshead screwdriver.

Remove and Clean the Parts

5. Remove the Hopper, the Force Feeder, and the Tooling.
 - 5.1 Note: Please refer to the replace Tooling instructions on page 33 for further assistance.
6. Remove the Force Feeder Wear Plate, Take-Off Blade, and Force Feeder Scraper.
 - 6.1 Note: Please refer to the replace Force Feeder Wear Plate instructions on page 42 and the replace Take-Off Blade and Force Feeder Scraper instructions on page 45 for further assistance.
7. Clean the Force Feeder Wear Plate, Take-Off Blade, and Force Feeder Scraper with a clean cloth and warm soapy water.
8. Dry each part immediately after it is cleaned and rinsed.
9. Sanitize each part with a clean cloth.



Dismantle and Clean the Force Feeder

10. Remove the screws on the outside of the Force Feeder with a crosshead screwdriver.

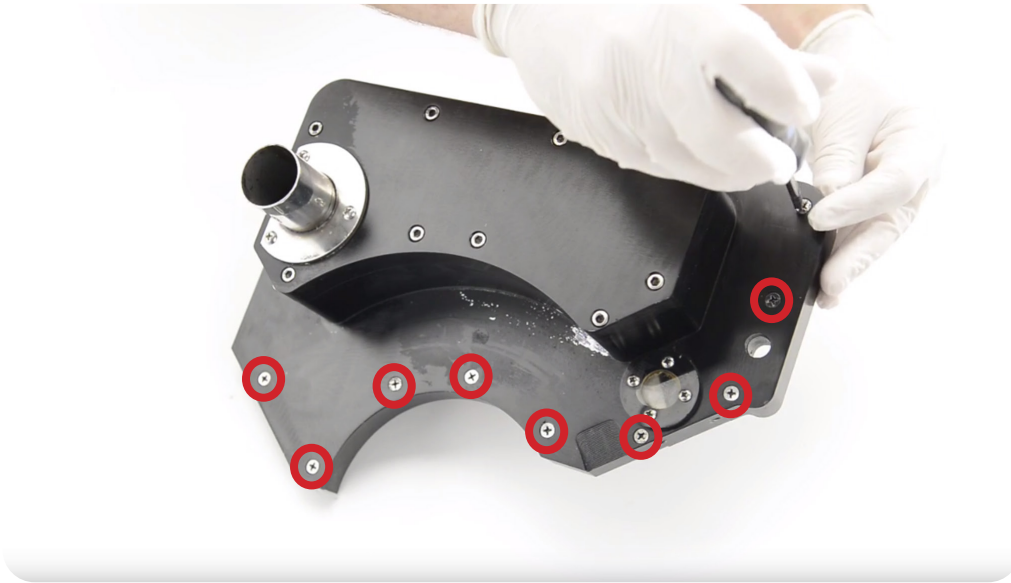

11. Pull up the top of the Force Feeder from the bottom.



12. Spray the Force Feeder's bottom with a cleaner, particularly where the propellers come into contact with powder.

13. Rinse the cleaner with potable water and dry the bottom of the Force Feeder.

14. Sanitize the Force Feeder's bottom with a clean cloth.

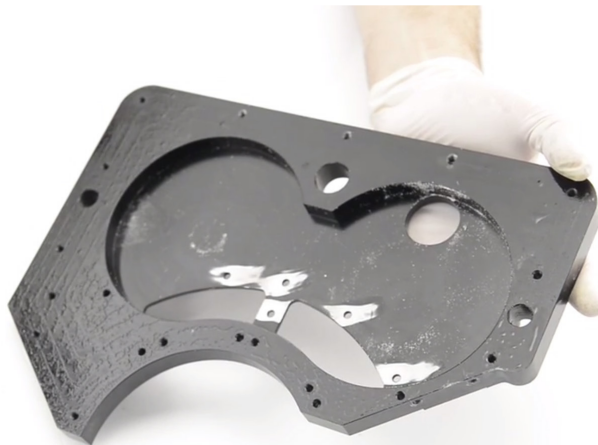

15. Remove the Force Feeder's paddles with an Allen key.

15.1 Note: Hold onto one of the paddles while removing the other to keep it from moving.

15.2 Note: If paddles are difficult to remove, insert a flathead screwdriver underneath it for leverage.

16. Clean the paddles and their base with soapy water.

17. Dry the paddles and their base immediately after they are cleaned and rinsed.

18. Sanitize the paddles and their base with a clean cloth.



19. Spray the Force Feeder gearing surface with a cleaner.

20. Rinse the cleaner with potable water and dry the area.

21. Sanitize the Force Feeder gearing surface with a clean cloth.



22. Reassemble the Force Feeder's components.

Clean the Interior

23. Pull off all the panel doors.
24. Use a brush to bring powder debris out from hard to reach places.
25. Vacuum the top section of the RTP 10i®.
 - 25.1 Note: Ensure that you vacuum inside the top panel where the Turret is positioned.
26. Vacuum the entire area inside the bottom part of the panel door encasement.
 - 26.1 Note: Be sure to vacuum both levels and all corners of the RTP 10i® base.

Note: LFA recommends using our Die Seat Cleaner. You can order the Die Seat Cleaner and Insertion Ring on our website at <https://www.lfatabletpresses.com/die-seat-cleaner-insertion-ring>

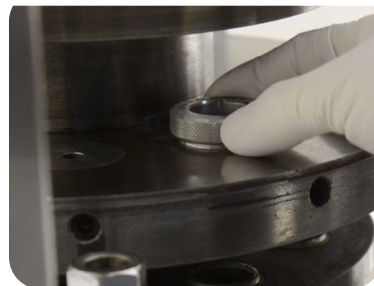

Clean Upper/Lower Shrouds and the Tooling

27. Take a clean cloth and carefully wash the Upper Shroud and Lower Shroud.
28. Dry the Upper Shroud and Lower Shroud immediately after it is cleaned and rinsed.
29. Sanitize the Upper Shroud and the Lower Shroud with a clean cloth.

Clean the Tooling

30. Take an Upper Punch/Lower Punch/Die and bring it to the bowl of soapy water.
 - 30.1 Note: To ensure that all dirt and debris are removed, wash one Tooling piece at a time.
31. Take a clean cloth and carefully wash the part thoroughly.
 - 31.1 Note: Use the toothbrush for difficult-to-remove debris. When cleaning tooling, use non-abrasive cleaning equipment such as a soft pipe cleaner and soft cloth.
32. Dry Tooling piece immediately after it is cleaned and rinsed.
33. Sanitize Tooling piece with a clean cloth.
34. Lubricate the Tooling piece.
35. Repeat steps 30-34 for each remaining piece of Tooling until they are all clean.



Clean the Base

36. Spray the RTP 10i® exterior and interior base with the cleaner, particularly in the Tooling's location.
37. Rinse the cleaner off with potable water and dry the RTP 10i® base.
38. Sanitize the the RTP 10i® base with a clean cloth.

Cleaning Schedule Matrix

Part	Frequency							
	After installing machine	After every use	Before every use	In between products that present a cross contamination risk	Weekly	Monthly	Before placing in storage	After removing from storage
Tooling	Remove from machine	Remove from machine	Install into machine	Remove from machine	N/A	N/A	Remove from machine	Install into machine
Hopper	Remove from machine	Remove from machine	Install into machine	Remove from machine	N/A	N/A	Remove from machine	Install into machine
Perspex Casing	Clean on machine	Clean on machine	Clean on machine	Clean on machine	N/A	N/A	Clean on machine	Clean on machine
Turret and surrounding area	Clean in machine	Clean in machine	Clean in machine	Clean in machine	N/A	N/A	Clean in machine	Clean in machine
Fill Tray and surrounding area	Remove from machine	Remove from machine	Install into machine	Remove from machine	N/A	N/A	Remove from machine	Remove from machine
Upper Cam Housing (Upper Roller Cam and Upper Precompression Roll)	Clean in machine	Clean in machine	Clean in machine	Clean in machine	Clean in machine	Remove from machine	Clean in machine	Clean in machine
Upper Tracking	Clean in machine	Clean in machine	Clean in machine	Clean in machine	Clean in machine	Remove from machine	Clean in machine	Clean in machine
Lower Cam Housing (Lower Roller Cam and Lower Precompression Roll)	Clean in machine	Clean in machine	Clean in machine	Clean in machine	Clean in machine	Remove from machine	Clean in machine	Clean in machine
Lower Tracking	Remove from machine	Clean in machine	Clean in machine	Clean in machine	Clean in machine	Remove from machine	Clean in machine	Remove from machine
Motor	Clean in machine	Clean in machine	Clean in machine	Clean in machine	Clean in machine	Remove from machine	Clean in machine	Clean in machine
Gearbox	Clean in machine	Clean in machine	Clean in machine	Clean in machine	Clean in machine	Remove from machine	Clean in machine	Clean in machine
Drive Belt Pulleys	Clean in machine	Clean in machine	Clean in machine	Clean in machine	Clean in machine	Remove from machine	Clean in machine	Clean in machine
Exterior	Clean on machine	Clean on machine	Clean on machine	Clean on machine	Clean on machine	Remove from machine	Clean on machine	Clean on machine
Ejection Tray	Remove from machine	Remove from machine	Install into machine	Remove from machine	N/A	N/A	Remove from machine	Remove from machine

Cleaning Level Key	
Level 1 - Remove powder	
Level 2 - Dry clean with cloth	
Level 3 - Dry clean and re-lubricate if specified in lubrication schedule	
Level 4 - Wet clean and re-lubricate if specified in lubrication schedule	
Remove from machine - Take part out of machine and clean if required. Store it correctly or install back into machine.	
Install into machine - Install part into the machine and make sure that it has been cleaned. If needed, lubricate to the level required.	
Clean on/in machine - Clean the part while in the machine and do not remove it. Make sure that all contact surfaces are clean to the level required.	

This cleaning matrix is intended as a guide only and is not an exhaustive list. All cleaning schedules will need to be adapted to the industry and product, following industry regulations and the material safety data sheets that come with specific products. Please check with your Food Safety Manager/Department, Quality Control Manager/Department, or other relevant internal departments at your company before using.

Storing the RTP 10i[®]

After its thorough cleaning, the RTP 10i[®] needs to be stored in the proper conditions. It is important to store it in an environment in which the machine is safe from rusting. The RTP 10i[®]'s high traction areas and the Tooling need to be lubricated separately before you store them.

Tools and Materials Needed

- Plastic wrapping to cover machine
- Airtight container for Upper Punches, Lower Punches, and Dies (if in storage for more than a week)
- Grease gun
- Lubricant/grease (NSF approved lubricant if machine has a high chance of contact with the food or drug product)
- Disposable latex/rubber gloves (for food grade products and to protect hands from lubricant)
- Hairnet and/or beard net (food grade products only)
- Sterile shoe covers (food grade products only)

Instructions

Note: Wear latex/rubber gloves (and appropriate food grade attire if applicable) during this process.

Lubricating the Tooling

If you are not using the machine for more than a week, store the Tooling in an airtight container (like the one pictured below) and cover it with lubricant to prevent rust formation. If not, simply lubricate each part of the Tooling, particularly the heads and barrels of the Upper and Lower Punches, and reinsert it back into the machine.



Lubricating the Main Worm Gear

The Main Worm Gear is mounted above the Motor in the lower section of the tablet press. Visually inspect the Main Worm Gear's eye glass to see the oil level. Apply WA 460 Oil (0.55 L) whenever it is dry.



Lubricating the Grease Points and High-Traction Parts

1. Pull off all of the lower panel doors from the RTP 10i®.
2. Remove the Hopper and raise all the Perspex Casing's doors.
3. Lubricate the Upper Roller Cam's oil well's wick on top of the machine with a grease gun.



4. Lubricate the grease nipples located in the centers of the Upper Roller Cam and the Lower Roller Cam.



Appendix

Glossary

Term	Definition
API/Active Pharmaceutical Ingredient	Any substance or mixture of substances used that is an active ingredient in the drug product.
Binding agent	See excipient.
Die	The part of the Tooling that makes up the hole in which the powder is compressed and shaped into a tablet.
Die bore	The cavity inside the middle of the Die.
Die face	The very top flat surface of the Die.
Ejection height	The height at which the Lower Punch is lifted to for a tablet's ejection from the machine.
Excipient	A substance formulated alongside the API that acts as a binding agent in the tablet powder.
Fill depth	The amount of space that the powder can flow into in the Die.
Formulation	Powder mix of the excipient and the API that is compressed to make tablets.
Granular material	See Formulation.
Kilonewton (kN)	The force to accelerate a mass of 1 kg at a constant 1 m per second. The RTP range's pressure is measured in this unit.
Punches	The Upper Punch and Lower Punch have concave endings in the shape of the desired tablet. When the punches meet, they compress the powder between.
Punch pressure	The adjustable amount of force that is used to press tablets.
RTP®	LFA trademarked term for rotary tablet press.
Tooling	Enables a tablet press to form tablets. It consists of a Die, Upper Punch, and Lower Punch.

Description of RTP 10i® Parts

Tooling

The Tooling consists of the Dies, the Upper Punches, and the Lower Punches. They all work as a set and compress the powder into tablets. Order at <https://www.lfatabletpresses.com/products/tablet-press-tooling>



Upper Roller Cam

The Upper Roller Cam guides the Upper Punches to move along the Upper Tracking. It can also be used to slightly adjust the pressure on the Upper Punches. Order at <https://www.lfatabletpresses.com/upper-roller-cam-rtp-10i>



Take-Off Blade and Force Feeder Scraper

The Force Feeder Scraper (nonmetal) helps keep the powder flowing into the Dies' bores, and the Take-Off Blade (metal) aids in tablet ejection. Order at <https://www.lfatabletpresses.com/scraper-blade-rtp-10i>

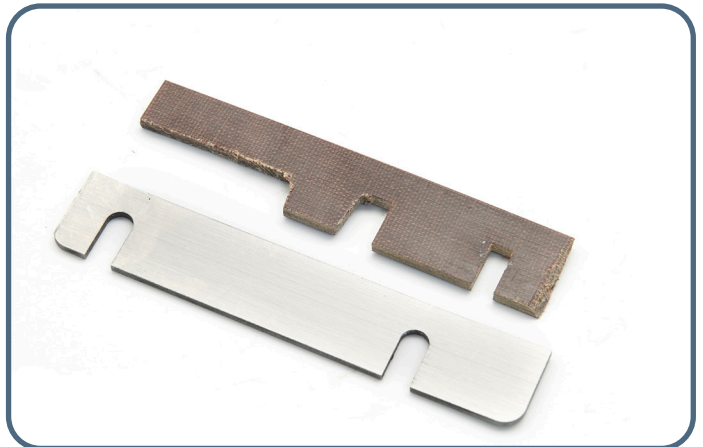

Lower Roller Cam

The Lower Roller Cam guides the Lower Punches to move along the Upper Tracking. It is also used to adjust the pressure on the Lower Punches. Order at <https://www.lfatabletpresses.com/lower-roller-cam-rtp10i>



Lower Tracking Kit

The Lower Tracking Kit consists of three components: the Ejection Cam, the Fill Cam, and the Dosing Cam. These all guide and move the Lower Punches. Order at <https://www.lfatabletpresses.com/lower-tracking-kit-rtp-10>

Hopper

The Hopper contains the powder and allows it to flow into the Force Feeder and into the Dies' bores. Order at <https://www.lfatabletpresses.com/rtp-10i-hopper>



Upper Tracking

The Upper Tracking holds the Upper Punches and guides their movement through the Turret. Order at <https://www.lfatabletpresses.com/rtp-10i-upper-tracking>



Perspex Casing Door

The Perspex Casing Doors (4) make up an enclosure that covers the Turret and Force Feeder. Order one at <https://www.lfatabletpresses.com/perspex-door-rtp-10i>



Force Feeder Kit

The Force Feeder Kit includes the following:

- Aluminum Force Feeder Housing
- Gearing to drive impeller blades
- Two impeller blades
- Mounting struts
- Drive motor
- Motor to Feeder driveshaft
- Turret protection parts (brass wear part)

Order at <https://www.lfatabletpresses.com/rtp-10i-force-feeder-kit>

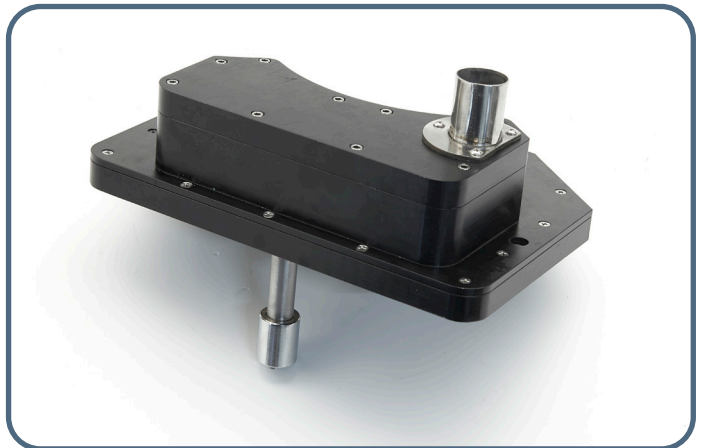

Ejection Cam

The Ejection Cam pushes the Lower Punches up through the Die bores to eject the tablets from the press. Order at <https://www.lfatabletpresses.com/ejection-cam-rtp-10i>



Fill Cam

The Fill Cam pulls down the Lower Punches into the Die bores, which allows powder to enter. Order at <https://www.lfatabletpresses.com/rtp-10i-fill-cam>

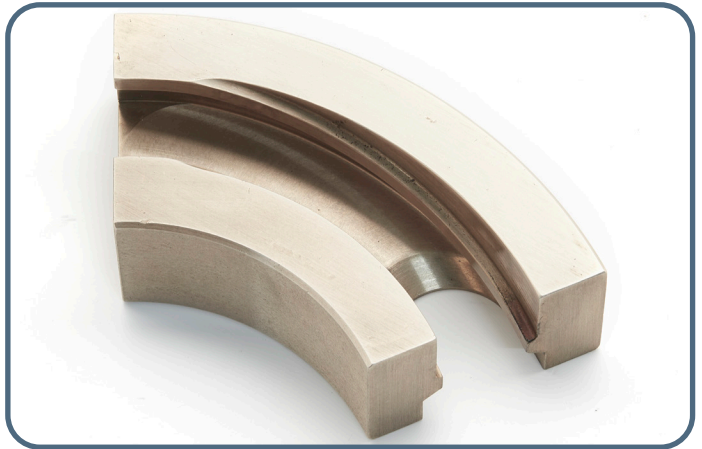

Dosing Cam

The Dosing Cam adjusts the weight of the tablet that results from powder compression. Order at <https://www.lfatabletpresses.com/rtp-10i-dosing-cam>

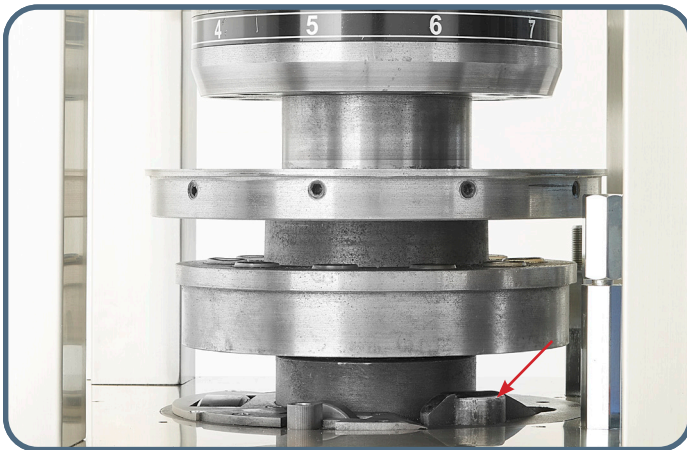

Side Panel Door Handle

The Side Panel Door Handles are used to remove and reattach the Side Panel Doors. Order one at <https://www.lfatabletpresses.com/rtp-10i-metal-door-handles>



Hopper to Force Feeder Connecting Pipe

The Hopper to Force Feeder Connecting Pipe allows powder to be transferred from the Hopper to the Force Feeder. Order at <https://www.lfatabletpresses.com/rtp-10i-hopper-force-feeder-connecting-pipe>

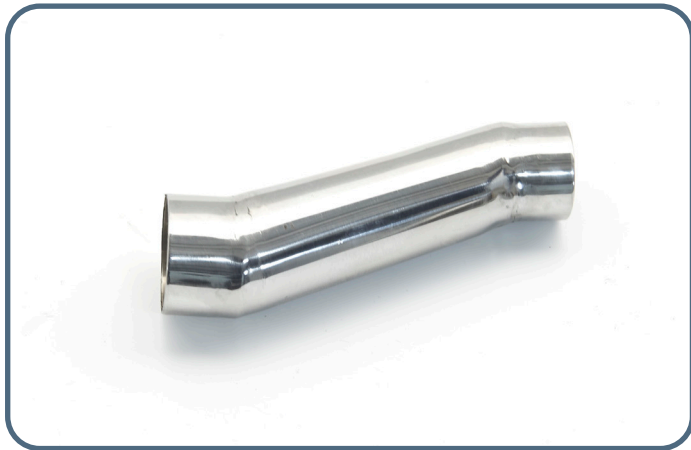

Lower Pre-Pressure Roller Cam

The Lower Pre-Pressure Roller Cam provides the initial compression force to the Lower Punches. Order at <https://www.lfatabletpresses.com/pre-presser-lower-cam-rtp-10i>

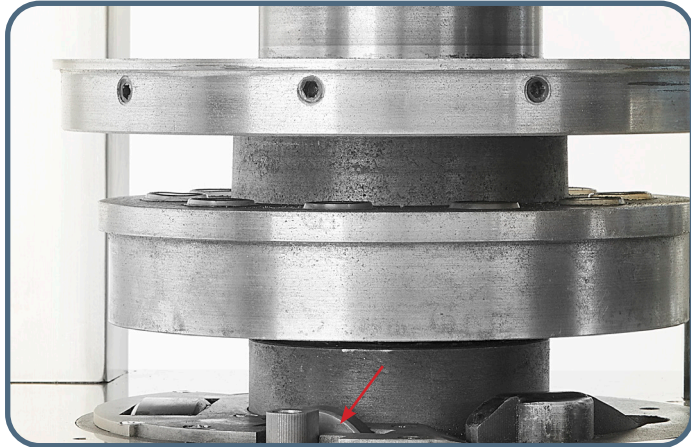

Upper Pre-Pressure Roller Cam

The Upper Pre-Pressure Roller Cam provides the initial compression force to the Upper Punches. Order at <https://www.lfatabletpresses.com/pre-presser-upper-cam-rtp-10i>

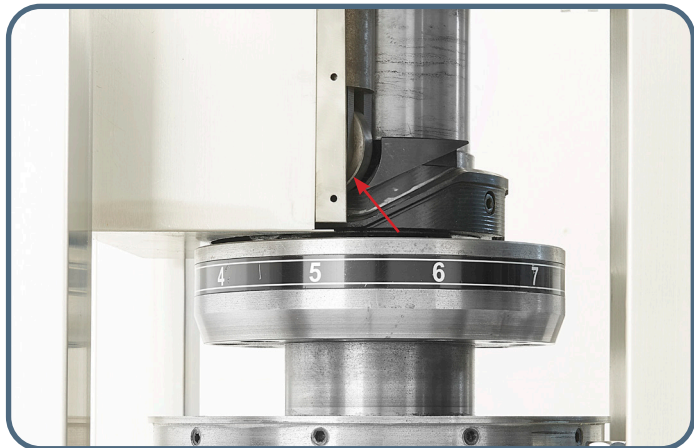

Anti-Vibration Feet

The Anti-Vibration Feet are fixed at the bottom of the machine and reduce noise emitted from the press. Order at <https://www.lfatabletpresses.com/anti-vibration-feet-rtp-10i>



Force Feeder Adjustment Base

The Force Feeder Adjustment Base is seated underneath the Force Feeder. It can be moved to adjust the height of the Force Feeder, which affects powder flow. Order at <https://www.lfatabletpresses.com/rtp-10i-force-feeder-adjustment-base>



Force Feeder Height Adjustment Nut

The Force Feeder Height Adjustment Nut is moved to change the Force Feeder's height from the Die table. Order at <https://www.lfatabletpresses.com/rtp-10i-force-feeder-height-adjustment-nut>



Force Feeder-Hopper Coupling

The Force Feeder-Hopper Coupling is situated at the top of the Force Feeder. The Hopper is able to distribute powder into the Force Feeder through this part. Order at <https://www.lfatabletpresses.com/rtp-10i-force-feeder-hopper-coupling>

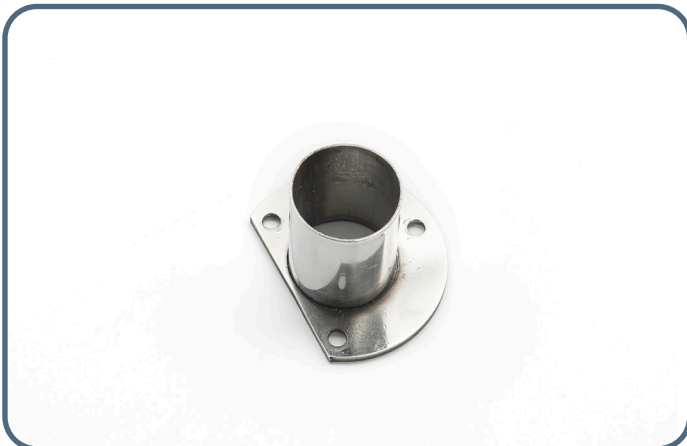

Force Feeder Paddles

The Force Feeder Paddles propel the powder into the Die bores. Order at <https://www.lfatabletpresses.com/rtp-10i-force-feeder-paddles>



Force Feeder Wear Plate

The Force Feeder Wear Plate is secured at the bottom of the Force Feeder. It is made of brass and meant to wear. Order at <https://www.lfatabletpresses.com/rtp-10i-force-feeder-wear-plate>



Lower Punch Retaining Puck

The Lower Punch Retaining Puck prevents the Lower Punches from falling out of the Turret. It also must be removed whenever installing new Tooling. Order at <https://www.lfatabletpresses.com/rtp-10i-lower-punch-retaining-puck>



Front Panel Electrical Door

The Front Panel Electrical Door can be opened to reveal the RTP 10i®'s electrical components. Order at <https://www.lfatabletpresses.com/rtp-10i-front-panel-electrical-door>



Lower Shroud (left and right)

The left and right pieces of the Lower Shroud cover the bottom part of the Turret and the Lower Punches. Order at <https://www.lfatabletpresses.com/rtp-10i-lower-shroud-left> and <https://www.lfatabletpresses.com/rtp-10i-lower-shroud-right>



Perspex Casing Door Back (Vacuum Opening)

This Perspex Casing Door is sold separately and has an opening for a vacuum connection. Order at <https://www.lfatabletpresses.com/rtp-10i-perspex-casing-door-back-vacuum-opening>



Perspex Casing Door Hinge

The Perspex Casing Door Hinge connects two Perspex Casing Doors together. Order at <https://www.lfatabletpresses.com/rtp-10i-perspex-casing-door-hinge>

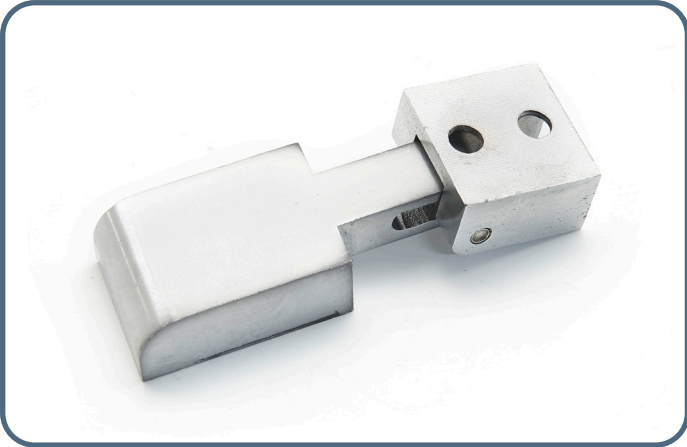

Pressure Adjustment Cog

The Pressure Adjustment Cog is controlled by an Adjustment Knob. It can be used to increase or decrease the punch pressure. Order at <https://www.lfatabletpresses.com/rtp-10i-pressure-adjustment-cog>



Adjustment Knob

The Adjustment Knobs control the RTP 10i®'s punch pressure, pre-pressure, and the tablet's fill depth. Order at <https://www.lfatabletpresses.com/rtp-10i-adjustment-knob>



Tablet Chute

The Tablet Chute aids in tablet ejection after the powder has been compressed. Order at <https://www.lfatabletpresses.com/rtp-10i-tablet-chute>

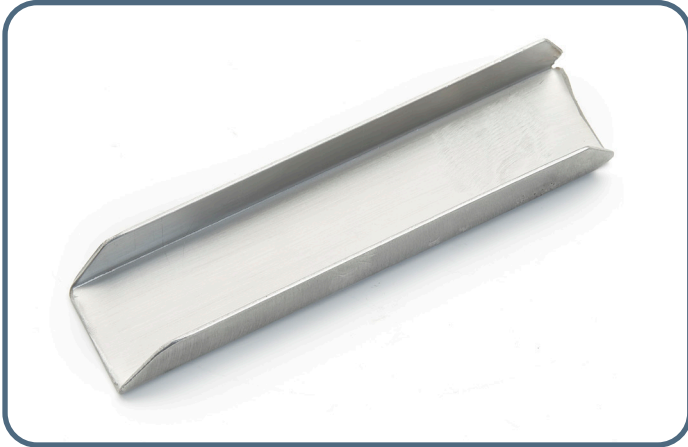

Tablet Chute Stand

The Tablet Chute Stand supports the Tablet Chute up against the RTP 10i®'s base. Order at <https://www.lfatabletpresses.com/rtp-10i-tablet-chute-stand>



Upper Shroud

The Upper Shroud Covers the top of the Turret and the Upper Punches. Order at <https://www.lfatabletpresses.com/rtp-10i-upper-shroud>

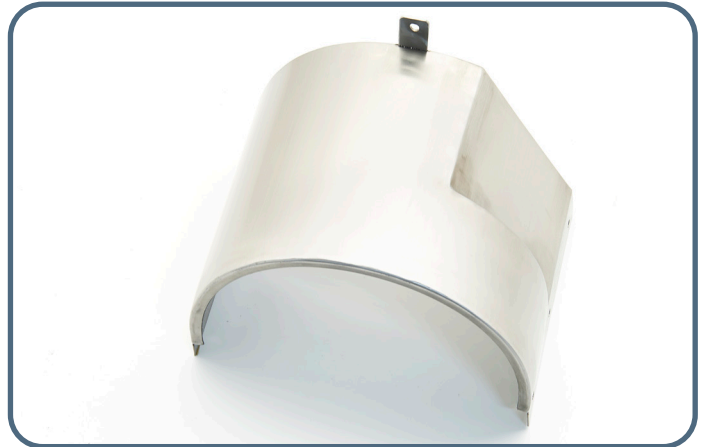

Vacuum-Turret Connection

The Vacuum-Turret Connection joins the vacuum to the Turret. Order at <https://www.lfatabletpresses.com/rtp-10i-vacuum-turret-connection>

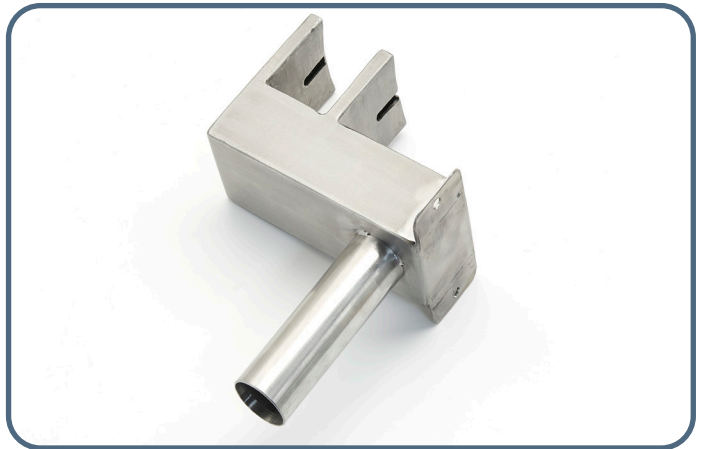

Material of Contact Parts

Contact Part	Material
Turret	Cast iron 250
Ejection Tray	SUS304
Hopper	SUS304
Tooling (Upper Punches, Lower Punches, and Dies)	User specified
Fill Tray	Tin bronze QSN-6-3
Force Feeder Scraper and Take-Off Blade	Bakelite and copper coat Zn

Technical Specifications

Tooling Specification	D Tooling
Number of Dies	10
Production capacity	12,000/hr
Max diameter of tablet	25 mm
Max fill depth	17 mm
Thickness of tablet	6 mm
Max pressure	60 kN
Max pre-pressure	10 kN
Number of filling stations	1
Double layered tablet	No
Kilowatts	2.2 kW
Volts	240 V (110 V on request)
Amps	13 A
Overall size	1680 mm x 700 mm x 710 mm
Weight	500 kg (1,102 lbs)
Floor loading (static)	0.8 kN/m ²
Max decibels	70.4 dB

Maintenance Checklist

Before Operation	
<input type="checkbox"/>	Visually inspect the tablet press and the parts.
<input type="checkbox"/>	Ensure all locking nuts are tight.
<input type="checkbox"/>	Visually inspect grease nipples and regrease where necessary.
<input type="checkbox"/>	Manually rotate the machine without powders to ensure that it is not jammed
<input type="checkbox"/>	Ensure Perspex Casing securely encloses the upper portion of machine.
<input type="checkbox"/>	Visually inspect electrical wires for any damage.
During Operation	
<input type="checkbox"/>	Tune the tablet press until the tablet size and weight are correct.
<input type="checkbox"/>	Listen for irregular knocking or clicking sounds. If heard, stop operation, release the pressure by rotating the Pressure Knob on the lefthand side of the machine counterclockwise a few times, and lubricate the machine.
<input type="checkbox"/>	Watch for buildup of powder in front of the Force Feeder. If occurring, either (a) make mix more granular, (b) check the Force Feeder for damage, (c) clear the buildup, or (d) adjust the Force Feeder.
<input type="checkbox"/>	Occasionally check the Motor's temperature. If it starts to overheat, turn off the machine, let it cool down, and grease it to ensure smooth operation.
<input type="checkbox"/>	Ensure that the Hopper does not run out of powder.
<input type="checkbox"/>	Weigh five or ten sample tablets to ensure the desired weights, tablet height, and hardness are being met.
<input type="checkbox"/>	Check to see that the Emergency Stop properly works.
After Operation	
<input type="checkbox"/>	Unplug machine and remove all excess powder with a bagless vacuum.
<input type="checkbox"/>	Remove the Perspex Casing, Hopper, Force Feeder, and Tooling and clean the inside of the tablet press.
<input type="checkbox"/>	Wipe down the other surfaces with a damp cloth.
<input type="checkbox"/>	Apply a layer of NSF approved grease to the entire tablet press.
<input type="checkbox"/>	Lubricate all grease nipples.
<input type="checkbox"/>	Store Tooling in an air-tight box with a small amount of grease.

Diagrams

RTP 10i® Upper Tooling and Die Dimensions

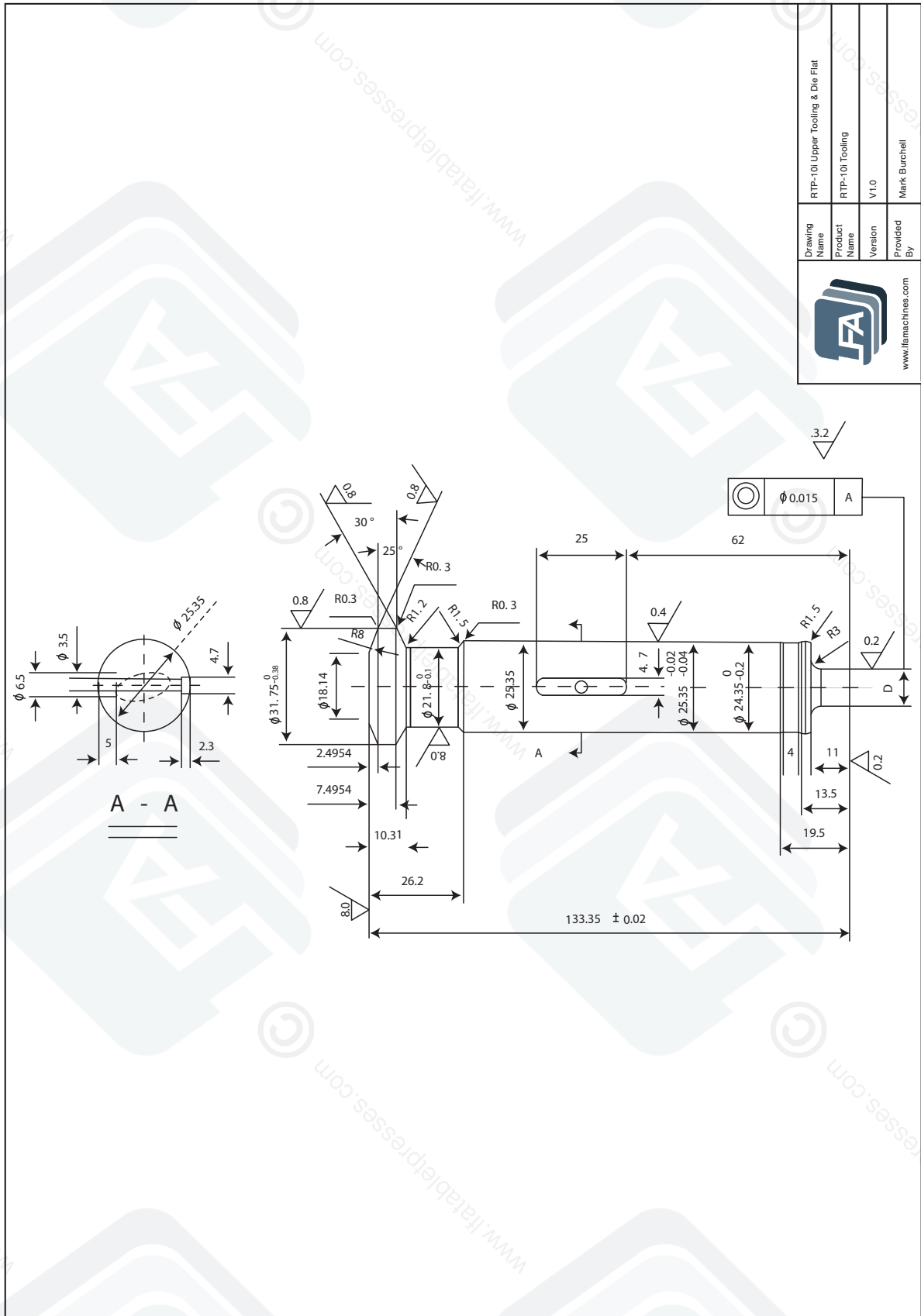

Drawing Name	RTP-10i Upper Tooling & Die Flat
Product Name	RTP-10i Tooling
Version	V1.0
Provided By	Mark Burchell



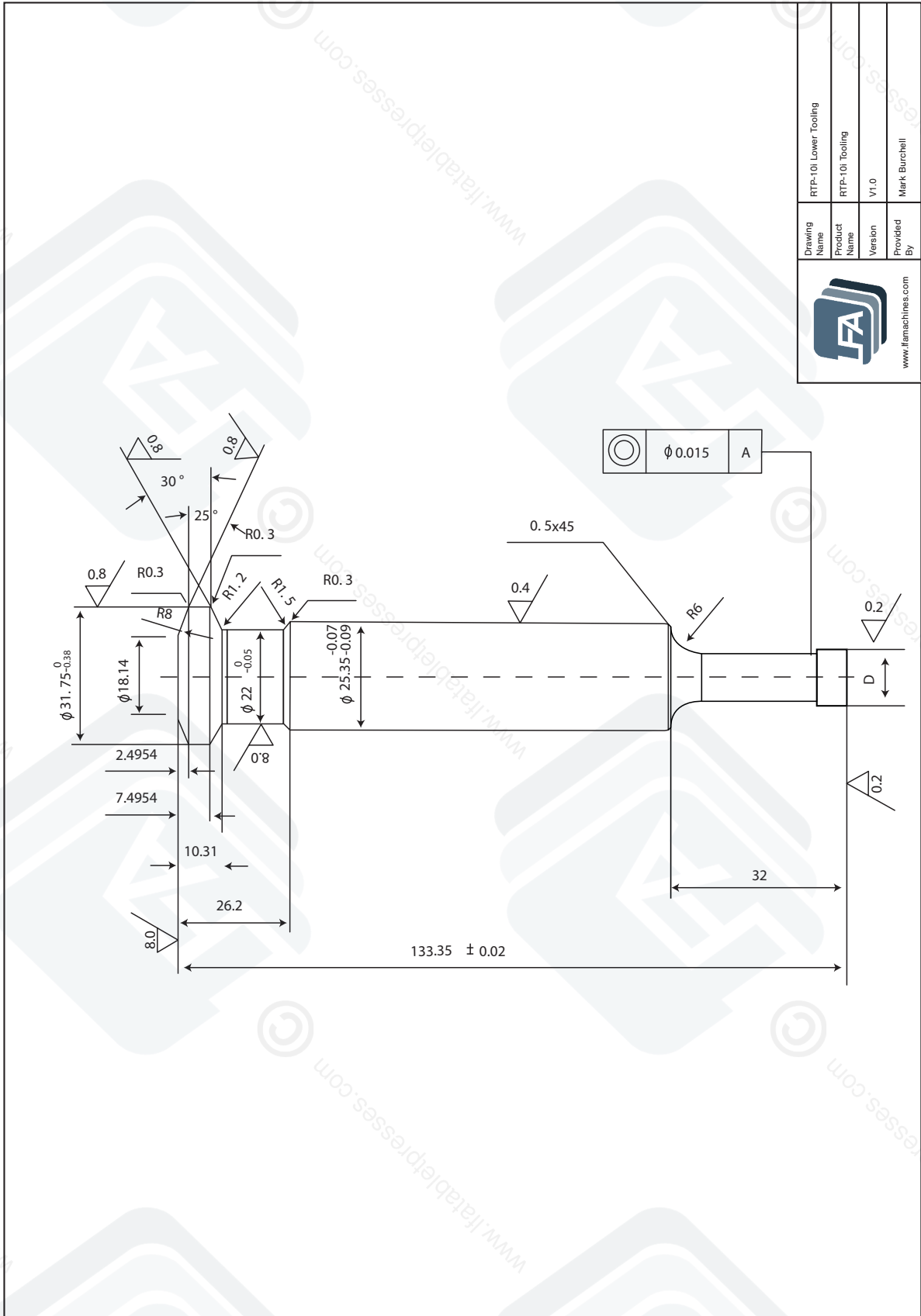

www.lfamaschines.com

RTP 10i® Lower Tooling Dimensions

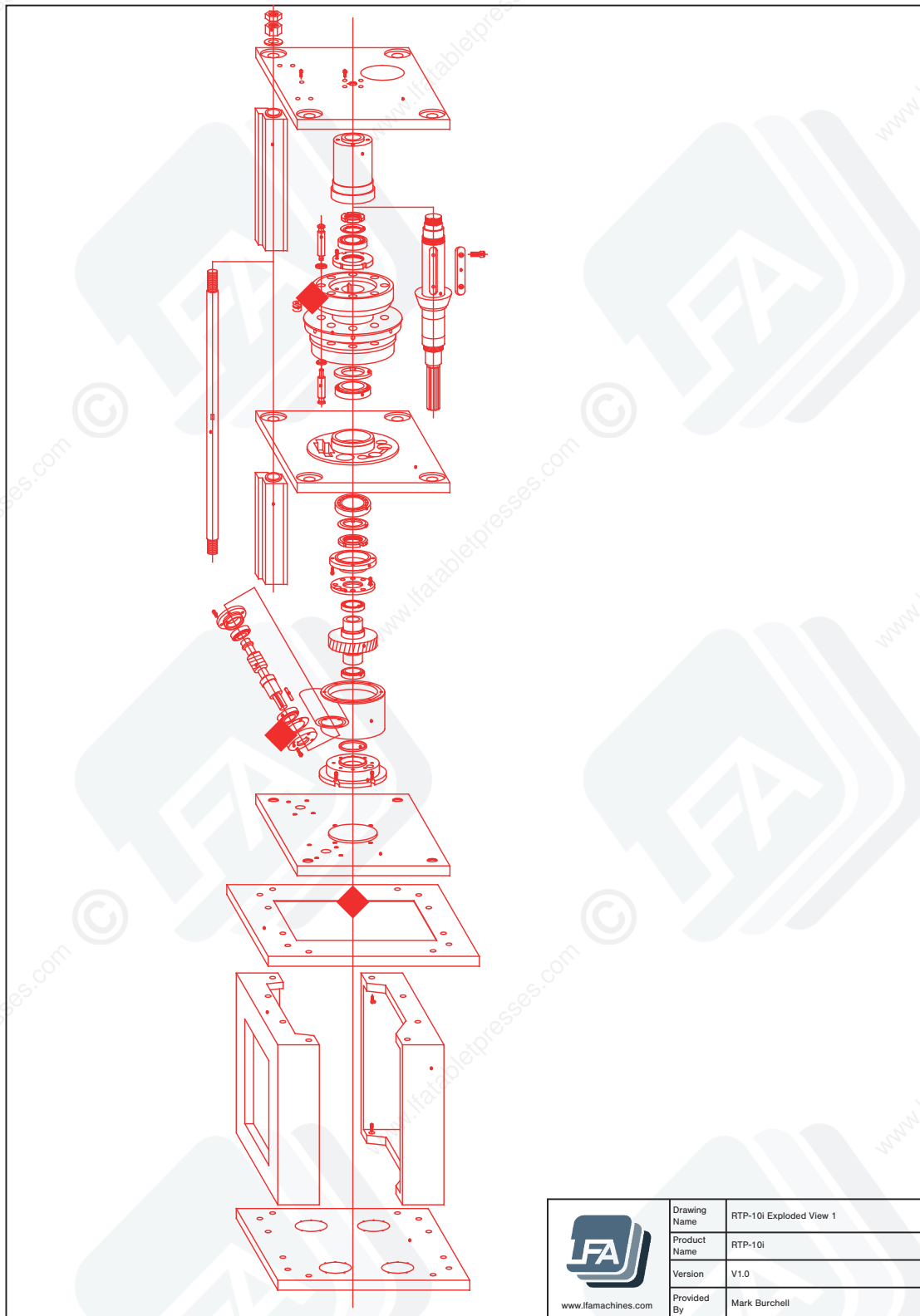

RTP 10i® Exploding Diagram



 www.ifamachines.com	Drawing Name	RTP-10i Exploded View 1
	Product Name	RTP-10i
	Version	V1.0
	Provided By	Mark Burchell

RTP 10i® Wiring Diagram 1

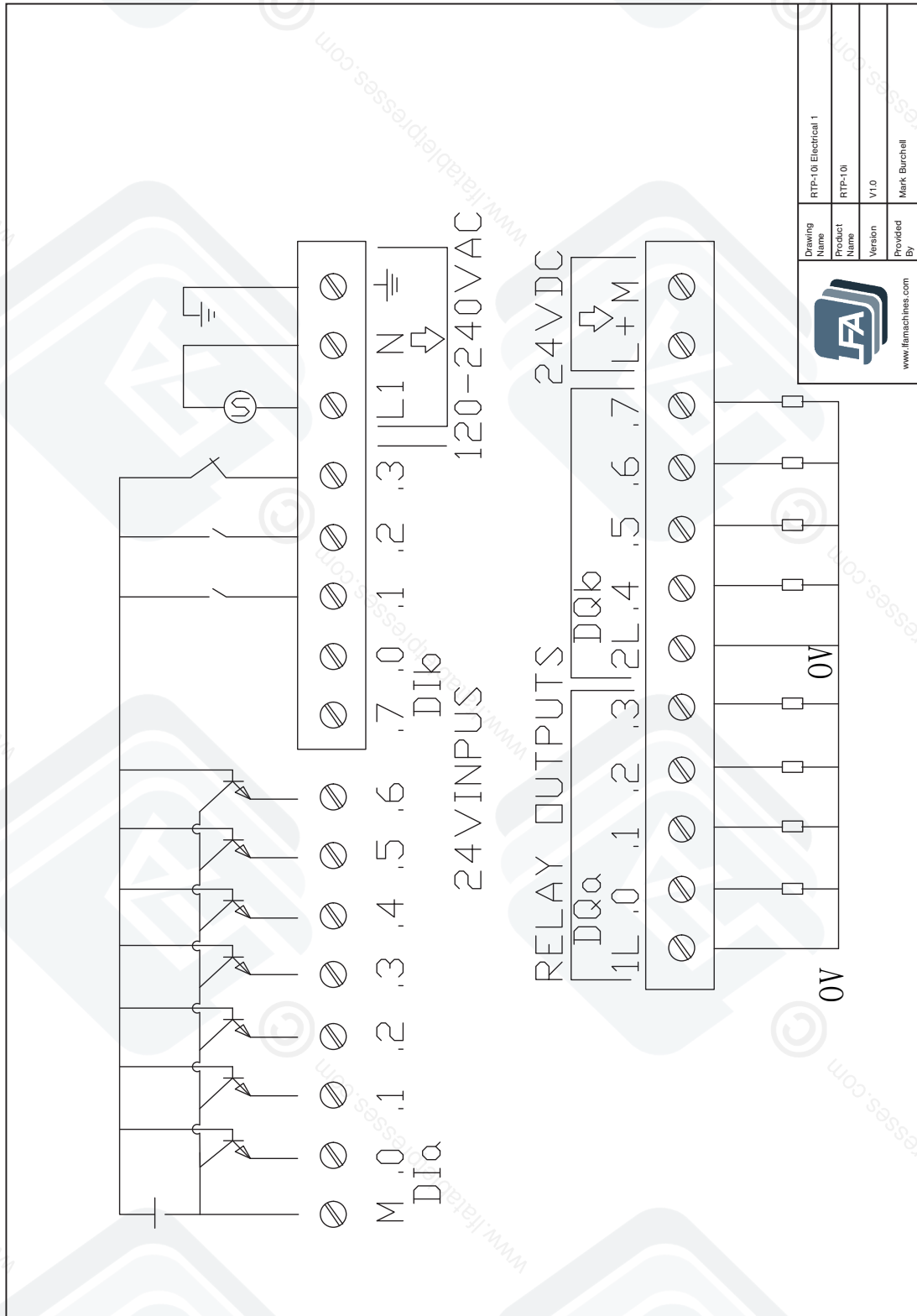

Drawing Name	RTP-10i Electrical 1
Product Name	RTP-10i
Version	V1.0
Provided By	Mark Burchell

www.ifa.com
www.ifa.com

RTP 10i® Wiring Diagram 2

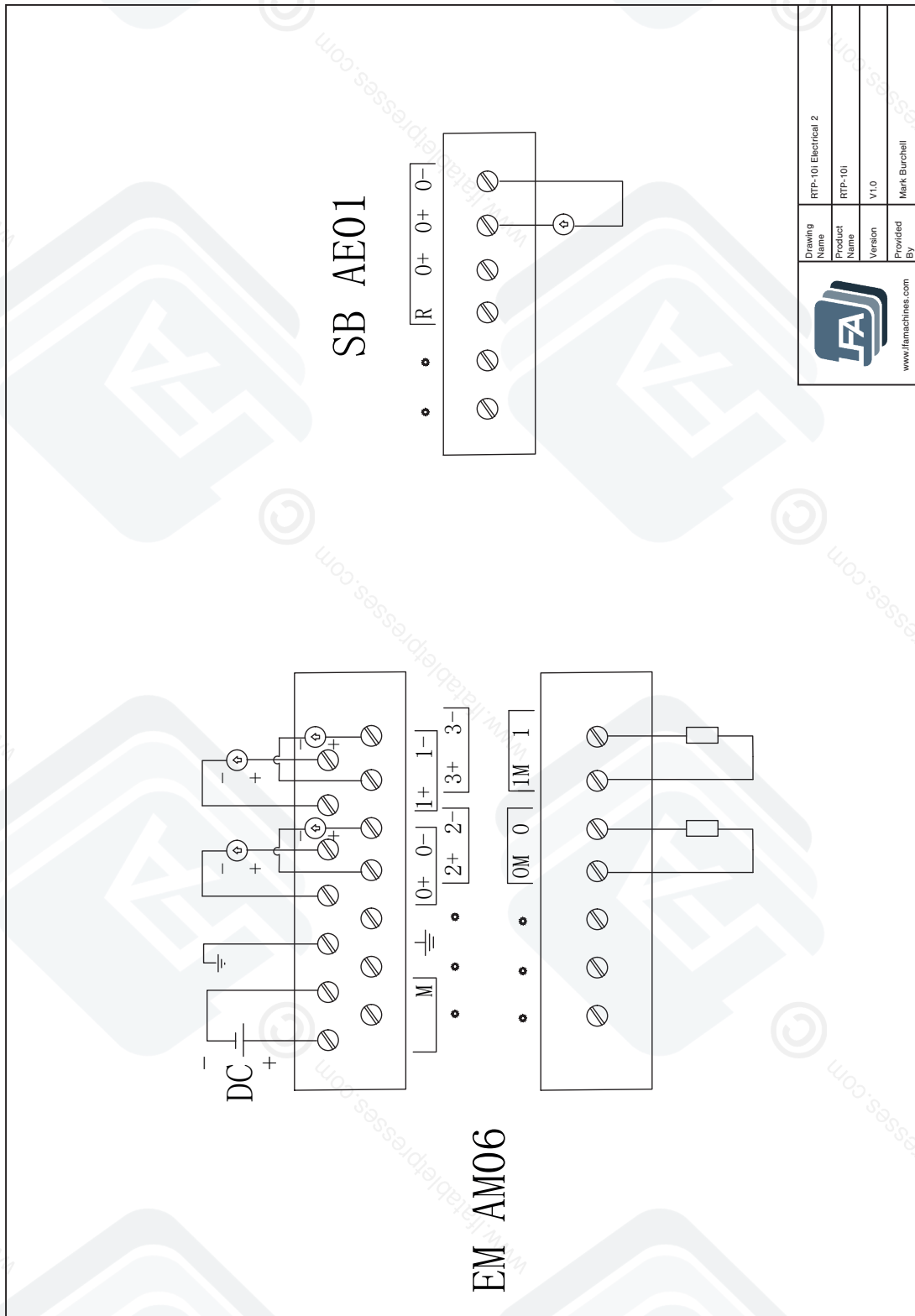

 www.lfsmachines.com	Drawing Name	RTP-10i Electrical 2
	Product Name	RTP-10i
	Version	V1.0
	Provided By	Mark Burchell

RTP 10i® Wiring Diagram 3

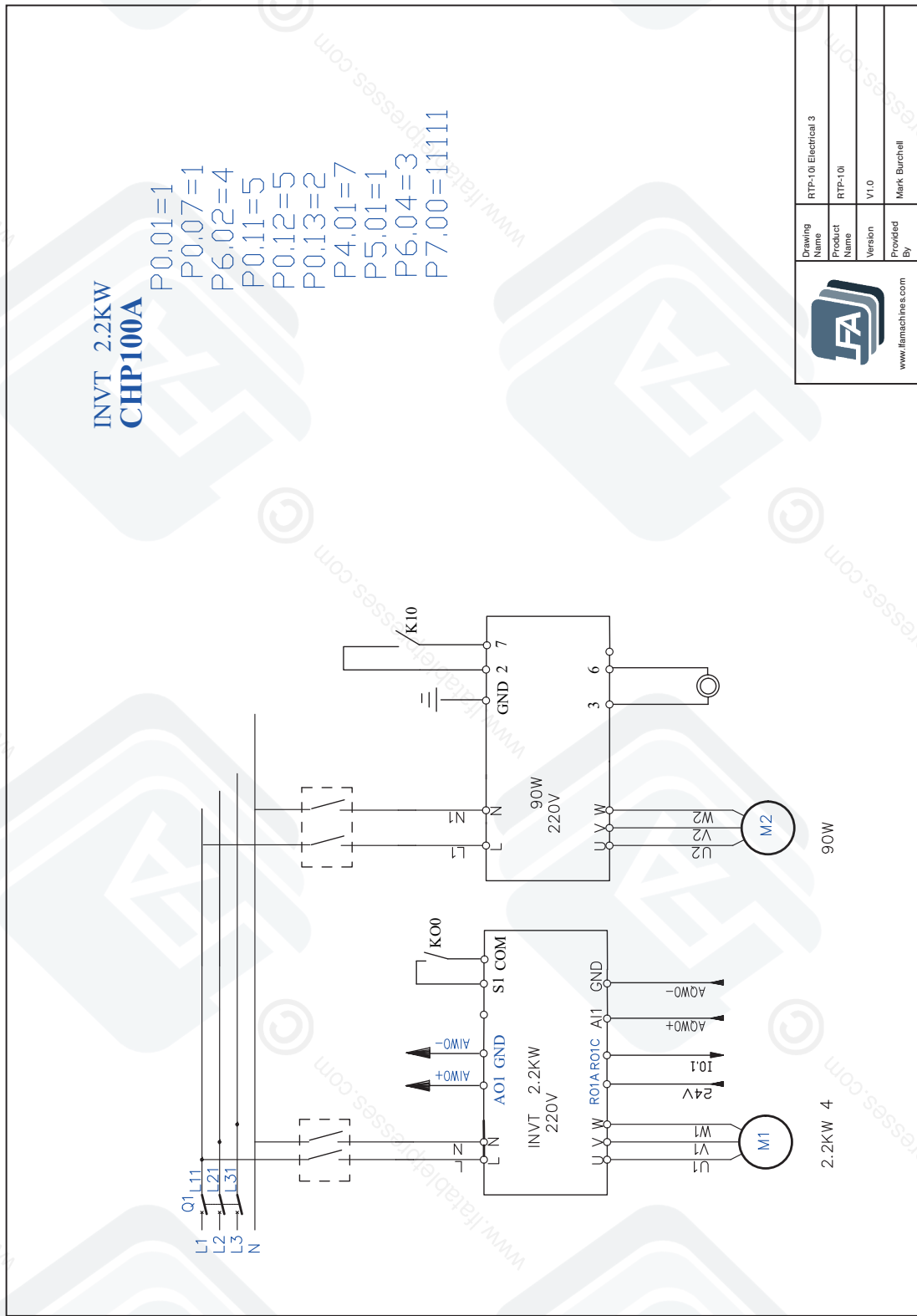

 www.ifa-machines.com	Drawing Name	RTP-10i Electrical 3
	Product Name	RTP-10i
	Version	V1.0
	Provided By	Mark Burchell

Resources

Helpful Links

Warranty

For information regarding the warranty policy of the RTP 10i® and other LFA products, please visit <https://www.lfatabletpresses.com/warranty>

LFA Website

In order to aid you in your tablet production, LFA Machines maintains a website that offers a breadth of useful information about the RTP 10i® and other tablet presses. Use our online tools such as the Tablet Mix Calculator to help you in your formulation production or read our regularly published articles that cover a whole range of topics about tablet presses and tablet production.

Visit the LFA homepage at <https://www.lfatabletpresses.com>

To create a free member's account, follow this link: <https://www.lfatabletpresses.com/customer/account/create>

LFA Machines YouTube Channel

Our YouTube videos provide you an opportunity to see demonstrations of how to use our tablet presses, common troubleshooting tips, and other LFA products such as capsule fillers and mixers. We regularly upload videos to give you a visual aid that will hopefully support you in your tablet production efforts. To watch our videos, visit <https://www.youtube.com/channel/UCwtbcwja77ai7vX2o34FUkQ>

LFA Machines Social Media

Social media is a great way to keep yourself updated on new developments and exciting things happening at LFA Machines. The list below contains our current social media pages:

Twitter: @lfatabletpress

Instagram: @lfatabletpresses

Facebook: <https://www.facebook.com/lfatabletpresses>

LinkedIn: <https://www.linkedin.com/company/lfa-machines-oxford-ltd/>

Contact Us

UK

LFA Machines Oxford Ltd
Unit 4B Rowood Estate
Murdock Road
Bicester, Oxfordshire OX26 4PP
+44 (0) 1869 250 234
sales@lfamachines.com
Monday-Friday
9AM-5PM GMT

US

LFA Machines DFW, LLC
955 N. Sylvania Ave
Fort Worth, TX 76111
English: +1 (682) 312 0034
Spanish: +1 (682) 312 0309
sales.usa@lfamachines.com
Monday-Friday
8:30AM-4:30PM UTC (Central)

Germany

LFA Machines Düsseldorf GmbH
Business Parc Am Trippelsberg 92
Düsseldorf, North-Rhine
Westphalia 40589
+41 21188250223
verkauf@lfamachines.com

Taiwan

LFA Machines Taiwan Ltd
7F-5, No. 2, Sec. 2 Taiwan Blvd
West District, Taichung City 403
Taiwan
+886 2773 74704
sales.asia@lfamachines.com



LFA MACHINES

Copyright © 2020 by LFA Machines

www.lfamachines.com

United Kingdom

Unit 4B
Murdock Road
Bicester
Oxfordshire
United Kingdom

United States

955 N Sylvania Ave
Fort Worth
Texas
United States

Germany

Business Parc Am
Trippelsberg 92
Düsseldorf
Germany

Taiwan

403, Section 2, 2
Taiwan Boulevard
Taichung City
Taiwan