

Dimplex

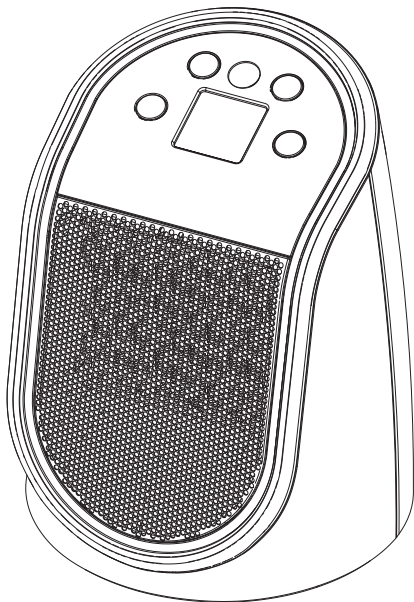

M2GT

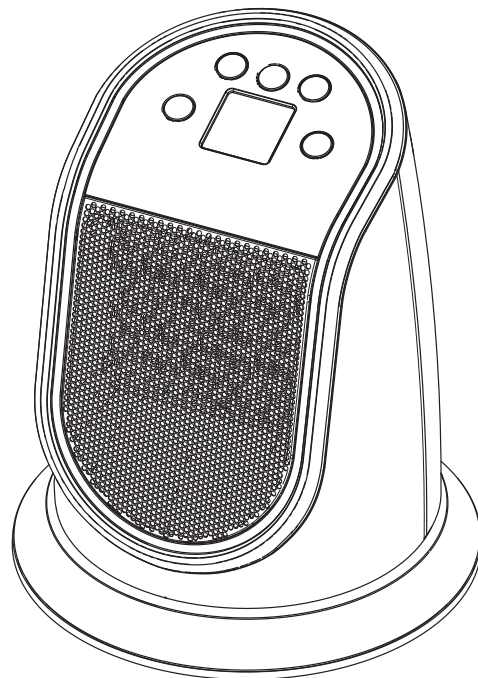

M2GTS

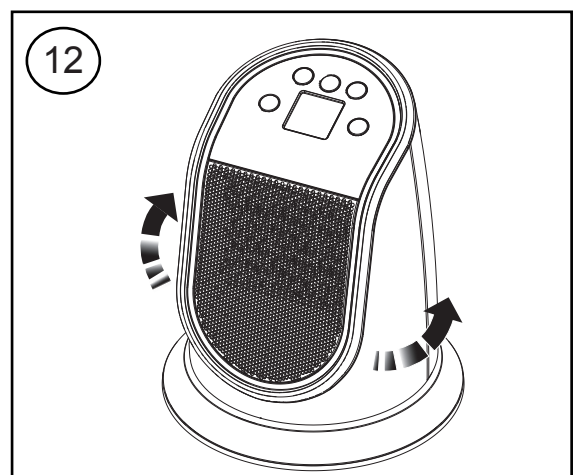
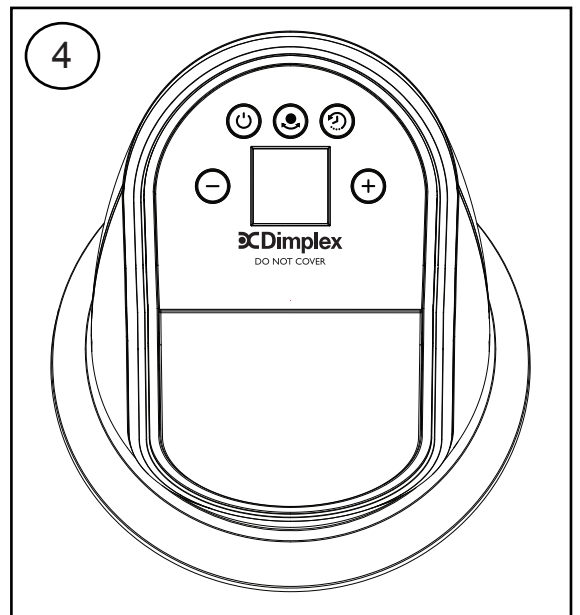
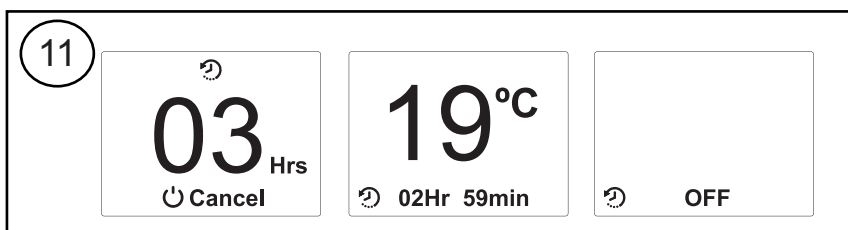
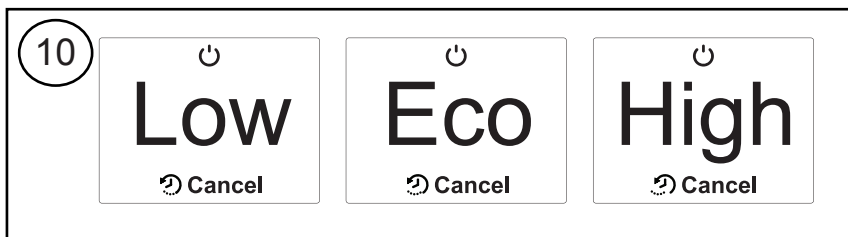
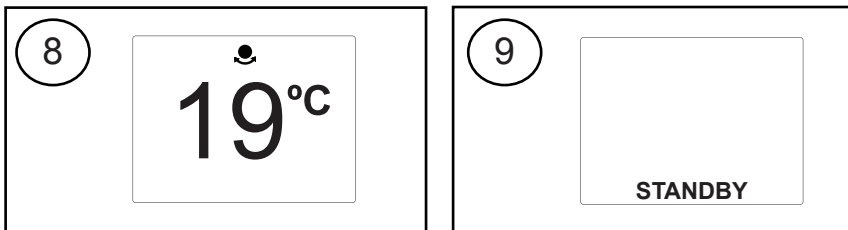
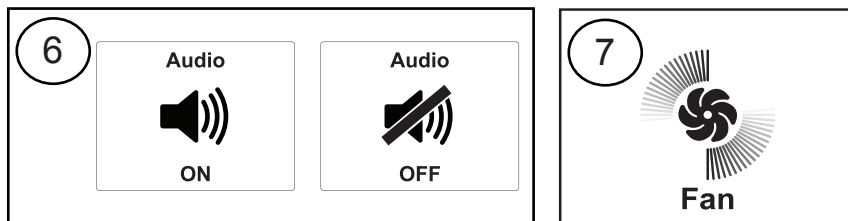
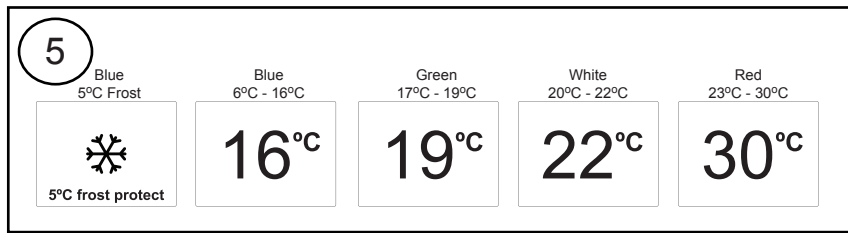
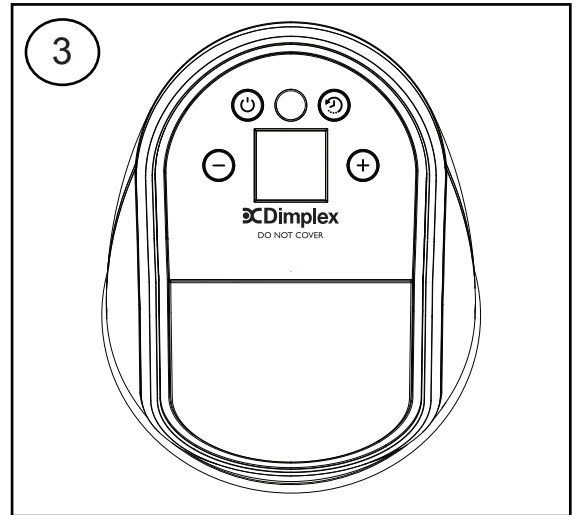
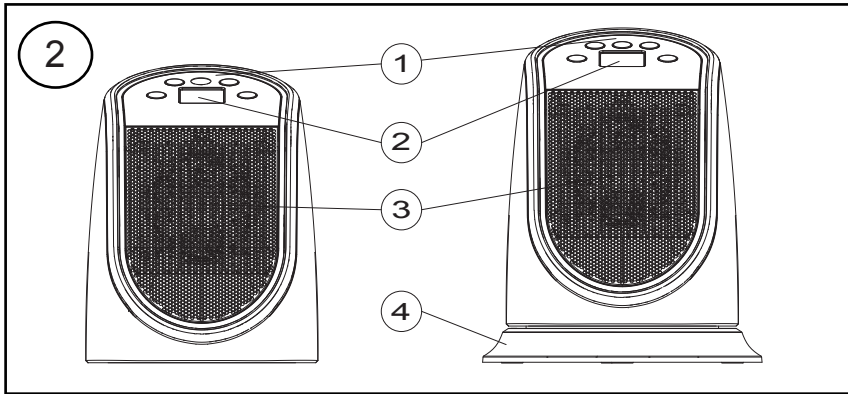
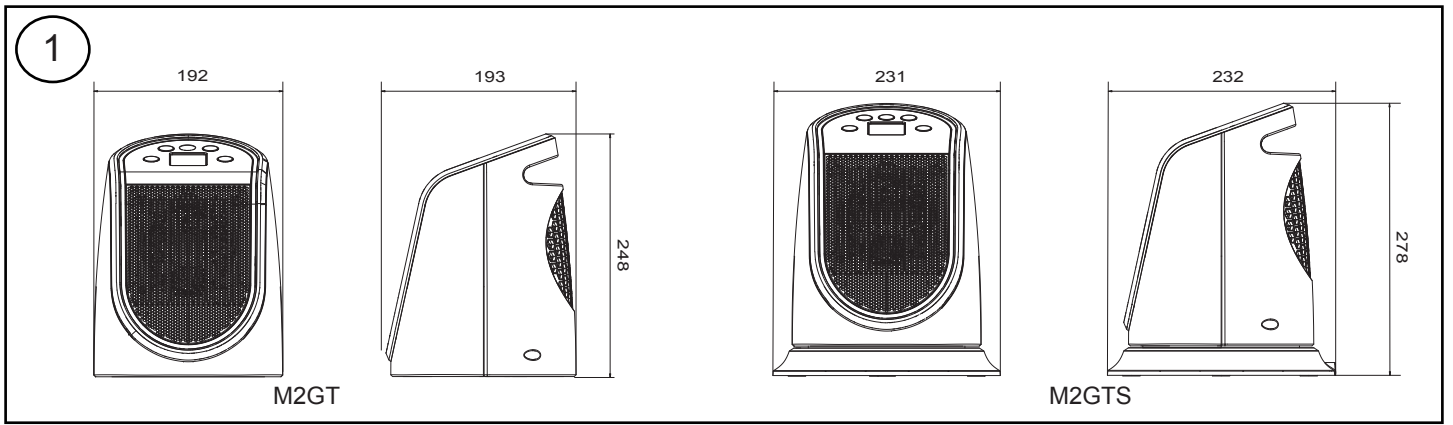

Dimplex M2GT & M2GTS Ceramic Fan Heaters

THESE INSTRUCTIONS SHOULD BE READ CAREFULLY AND RETAINED FOR FUTURE REFERENCE

Important Safety Advice

DO NOT use the heater in the immediate surroundings of a bath, a shower or a swimming pool.

DO NOT place the heater directly below a fixed socket outlet.

The socket-outlet must be accessible at all times to enable the mains plug to be disconnected as quickly as possible.

WARNING: In order to avoid a hazard due to inadvertent resetting of the thermal cut-out, this appliance must not be supplied through an external switching device, such as a timer, or connected to a circuit that is regularly switched on and off by the utility.

WARNING: In order to avoid overheating, do not cover the heater.

IMPORTANT: If the mains lead of this appliance is damaged, it must be replaced by the manufacturer or its service agent or a similarly qualified person in order to avoid a hazard.

CAUTION: Some parts of this product can become very hot and cause burns. Particular attention has to be given where children and vulnerable people are present.

WARNING: To avoid danger of suffocation please remove all packaging materials particularly plastic and EPS and keep these away from vulnerable people, children and babies.

WARNING: To avoid the risk of accidental strangulation from the supply cord all children and vulnerable people must be supervised when in the vicinity of the product whether it is working or not.

IMPORTANT: Avoid use of an extension cord because the extension cord may overheat and cause risk of fire.

IMPORTANT: The heater should always be used on a flat, stable surface.

DO NOT use this heater in small rooms when they are occupied by persons not capable of leaving the room on their own, unless constant supervision is provided.

DO NOT use the heater on deep pile carpets or the long hair type of rugs, or less than 750mm away from any overhanging surface.

IMPORTANT: Minimum distance to heater of 150mm from the back and sides and 300mm from the top to any surface must be maintained at all times.

WARNING: To reduce risk of fire, keep textiles, curtains, or any other flammable material a minimum of 1m distance from the air outlet.

DO NOT use heater to dry your laundry.

This appliance can be used by children aged from 8 years and above and persons with reduced physical, sensory or mental capabilities or lack of experience or knowledge if they have been given supervision or instruction concerning the use of the appliance in a safe way and understand the hazards involved. Children shall not play with the appliance. Cleaning and user maintenance shall not be made by children without supervision. Children of less than 3 years should be kept away unless continuously supervised. Children aged from 3 years and less than 8 years shall only switch on/off the appliance provided that it has been placed or installed in its intended normal operating position and they have been given supervision or instruction concerning the use of the appliance in a safe way and understand the hazards involved. Children aged from 3 years and less than 8 years shall not plug in, regulate and clean the appliance or perform user maintenance.

DO NOT COVER the heater or obstruct the air inlet and outlet openings in any way.

DO NOT operate the heater with the mains lead overhanging the front outlet grill.

DO NOT use this heater if it has been dropped.

DO NOT use if there are visible signs of damage to the heater.

The instruction leaflet belongs to the appliance and must be kept in a safe place. If changing owners, the leaflet must be surrendered to the new owner.

Electrical connection

This heater must be used on an **A.C.** ~ supply only and the voltage marked on the heater must correspond to the supply voltage. This heater is fitted with a plug incorporating a 13-amp fuse. When replacing the fuse, a 13-amp fuse approved by ASTA to BS 1362 must be used.

If the plug is not suitable for the socket outlets in your home, the plug must be cut off and an appropriate one fitted. A plug cut off from a mains lead will give a shock hazard if inserted into a 13-amp socket elsewhere in the house. To avoid this, it should be disposed of immediately.

NOTE: The fuse cover of a non-rewirable plug must be refitted when changing the fuse. Should the cover become lost, the plug must not be used until the correct replacement fuse cover is obtained from your supplier or by contacting our customer helpline.

IMPORTANT: The wires in this mains lead are coloured in accordance with the following code:

BLUE:	NEUTRAL
BROWN:	LIVE
GREEN & YELLOW:	EARTH

As the colours of the wires in the mains lead may not correspond with the coloured markings in your plug, proceed as follows:

Connect the **BROWN** wire to the terminal marked 'L' or coloured **RED**. Connect the **BLUE** wire to the terminal marked 'N' or coloured **BLACK**. **Note:** 'L' or 'N' must not be connected to the **EARTH** terminal marked 'E' or '⊕' or coloured **GREEN** or **GREEN AND YELLOW**.

If in doubt, consult your electrician.





Operation

Main Elements - See Fig. 2

1. Control Panel
2. Display Screen
3. Air Outlet
4. Oscillation Base (M2GTS Only)

The heat output is controlled electronically according to the room temperature. When the unit is plugged in the display screen will light up white with STANDBY displayed at the bottom of the screen, see Fig. 9, and the appliance will beep once. After 10 seconds the intensity of the display will fade to 20%. The display will remain lit until the appliance is disconnected from the mains or a button is pressed. The control panel elements are shown in Table 1, Fig. 3 (M2GT) and Fig.4 (M2GTS).

Table 1

	Standby
	Runback Time
	Plus Button
	Minus Button
	Oscillation (M2GTS Only)

To turn on the appliance, press the "⏻" button on the control panel. To turn off the appliance press the "⏻" again. A countdown from 10 to 1 will be displayed and then the heater will revert to standby mode, see Fig. 9. The first time the appliance is turned on the appliance will set to 22°C as the default temperature, the default mode setting is "Eco". Subsequently, when the appliance is turned on it will power on at the last set temperature and mode. The display will show the current set temperature, see Fig. 5. The set temperature range starts at 5°C and ends at 30°C. The set temperatures are colour coded to easily identify optimal settings. The colour coding is noted in Fig. 5. To change the set temperature press "+" to raise the desired temperature and press "-" to lower it. If either button is pressed and held for 1 second or more the temperature will continually rise or fall until button is released. When the air temperature rises above the set temperature, the heat will switch off but the fan will continue to run for 25 seconds. When the air temperature drops below the set temperature, the unit will come back on. If the heater is not operating this may be because the set temperature is lower than the room temperature. If no buttons have been pressed for 10 seconds, the display screen will go into sleep mode. The screen backlight will fade to 20% of its intensity.

Note: When in heating mode if the "⏻" button is pressed the fan will continue to run for 15 seconds while counting down 10 to 1 on screen.

Audio - see Fig. 6

When a button is pressed the heater emits an audible beep. If the "⏻" + "-" buttons are pressed and held for 2 seconds this will turn off audio for button presses. If both buttons are pressed and held again the audio will be turned on again. The screen will show either the audio on or audio off symbols as shown in Fig. 6. After 2 seconds display will return to the temperature screen.

Fan Only Mode - Fig. 7

If the "⏻" + "+" buttons are pressed and held for 2 seconds this will switch the appliance into fan only mode. In this mode the heating elements are powered down and the appliance will blow cool air. The fan symbol "🌀" will appear on the display when the appliance is in fan only mode. If the "⏻" + "+" buttons are pressed and held again for 2 seconds this will switch the appliance out of fan only mode and the display screen will return to the temperature screen.

Oscillation - See Fig. 8 & Fig. 12 (M2GTS Only)

The heater can be switched into oscillation mode by pressing the "🌀" button on the control panel. An oscillation graphic will appear at the top of the temperature screen, see Fig. 8. The heater oscillates back and forth on its base through 90 degrees as shown in Fig. 12.

Power Settings - see Fig. 10

The heater has 3 power settings. To cycle through these settings, press and hold the "⏻" button for 2 seconds. This will bring up the power setting screen. Press the "⏻" button again to cycle through the 3 settings, "Low", "High" and "Eco", as shown in Fig. 10. The settings will flash when displayed on the screen. Once a setting is left highlighted for 6 seconds it will then become selected and return to the temperature screen. Press the "⏻" button at any time to cancel the operation. When in "Eco" setting the heater will automatically switch between "High" (2000W) and "Low" (1000W) setting as required to maintain the set temperature.

'Intelligent' Eco Mode

This is the appliance default setting, the appliance will automatically start up in this setting once power is applied and the standby key is pressed. The LCD display will indicate the desired room temperature and the appliance will automatically regulate the room temperature accordingly. In this mode the appliance operates at full power, however the output of the appliance is automatically reduced and regulated as the room temperature approaches the desired level. This mode optimises energy use by calculating the most efficient and effective way to achieve the desired temperature setting. The desired room temperature can be adjusted at any time during operation by pressing the appropriate key.

Runback Timer Mode - See Fig. 11

The heater is fitted with a run-back timer feature which can be set in any of the operating modes. Press the "🌀" button to switch to the runback timer screen. The runback timer range is 1 to 12 hours. The displayed runback time will be flashing on screen, starting at "01 Hrs". Press the "🌀" button again to increase the runback time by 1 hour. Pressing "⏻" will cancel the runback operation. Once the desired runback time is left to flash for 6 seconds the timer will be set. The display will switch back to the temperature screen with the runback countdown displayed below as shown in Fig. 11. To cancel the current runback timer, press the "🌀" button. The runback countdown will flash to "OFF" then disappear. Once the run time has been set the heater will run and the runback countdown will remain on the display until the set time runs out. At this point the heater will switch to standby mode. To turn the heater back on, press the "⏻" button.

Note: If runback countdown is active in Fan mode the text below the fan symbol will alternate between "Fan" and runback countdown.

Tilt Switch

The heater is fitted with a tilt switch which will prevent the heater from working if the heater is accidentally tipped over in any direction.

Overheat Protection

The heater is fitted with a temperature limiter. If the air inlet or outlet grilles are restricted in anyway the temperature limiter switches the heater off automatically. To bring the heater back into operation, remove the cause of overheating then unplug the unit from the electricity supply for a few minutes. When the heater has cooled sufficiently reconnect and switch on the heater.

Electronic Thermostat

In addition, if the electronic thermostat reads an abnormal ambient room temperature it will cut the power to the heater and display "ERROR" on screen. When the temperature has cooled to an acceptable ambient room temperature it will restore power to the heater and "ERROR" will disappear from the screen. The heater will return to previous operation mode. The heater will then operate as normal, if the heater does not switch on this may be because the room temperature is still warmer than the set temperature.

Cleaning

Switch off the appliance first and disconnect the plug from the socket. Clean the housing with a moist cloth, vacuum cleaner or brush. Do not use any abrasive or caustic cleaning agents. Do not use any flammable cleaning agents e.g. petrol or spirit for cleaning the appliance. Never immerse the appliance in water. Air inlet and outlet area should be cleaned with a vacuum cleaner regularly. If the appliance is not used for extended periods, it must be protected against excessive dust and dirt.

Recycling



For electrical products sold within the European Community. At the end of the electrical products useful life it should not be disposed of with household waste. Please recycle where facilities exist. Check with your Local Authority or retailer for recycling advice in your country.

Model Identifier(s):		M2GT	M2GTS	
Heat output				
Nominal heat output	P _{nom}	2.0	2.0	kW
Minimum heat output (indicative)	P _{min}	1.0	1.0	kW
Maximum continuous heat output	P _{max,c}	2.0	2.0	kW
Auxiliary electricity Consumption				
At nominal heat output	e _{lmax}	0.0	0.0	kW
At minimum heat output	e _{lmin}	0.0	0.0	kW
In standby mode	e _{lSB}	0.00046	0.00046	kW
Type of heat output/ room temperature control				
Electronic room temperature control				Yes
Contact details		GDHV Millbrook House, Grange Drive, Hedge End, Southampton. SO30 2DF		

Warranty

What does a Dimplex Warranty cover?

Dimplex products deliver reliable service for normal, household use in domestic settings. All Dimplex products are individually tested before leaving the factory.

If you are a consumer and you experience a problem with your Dimplex product, which is found to be defective due to faulty materials or workmanship within the Warranty Period, this Dimplex Warranty will cover repair or - at the discretion of Dimplex - replacement with a functionally equivalent Dimplex product.

The Dimplex Warranty Period is 3 calendar years from the date of purchase of your Dimplex product, or the date of delivery of the product, if later. The Dimplex Warranty is conditional upon you providing the original purchase receipt as proof of purchase. Please therefore retain your receipt as proof of purchase.

If you do experience a problem with your Dimplex product please call the Helpline on **+44 [0]344 879 3588** or visit <https://www.dimplex.co.uk/support>. For ROI please email serviceireland@glendimplex.com or call **+353(0)1 842 4833**. We will need details of your Dimplex product and a description of the fault which has occurred. Once we receive your information and proof of purchase we will contact you to make the necessary arrangements.

If your Dimplex product is not covered by this Dimplex Warranty there may be a charge to repair your product. However, we will contact you for agreement to any charges before any chargeable service is carried out.

What is not covered by a Dimplex Warranty?

The Dimplex Warranty does not cover any of the following:

Any fault or damage to your Dimplex product due to faulty materials or workmanship occurring outside the 3 year Warranty Period.

Any fault or damage occurring to any pre-owned Dimplex product or to any other equipment or property.

Accidental damage to your Dimplex product or damage to your Dimplex product from external sources (for example, transit, weather, electrical outages or power surges).

Fault or damage to your Dimplex product which is:

- Not due to faulty materials or workmanship or which is due to circumstances outside Dimplex's control.
- Caused by use of your Dimplex product for anything other than normal domestic household purposes in the country where it was purchased.
- Caused by any misuse, abuse or negligent use of the Dimplex product, including but not limited to any failure to use it in accordance with the Operating Instructions supplied with the product.
- Caused by any failure to assemble, install clean and maintain your Dimplex product in accordance with the Operating Instructions supplied with the product unless this was carried out by Dimplex or its authorised dealers.
- Caused by repairs or alterations to your Dimplex product not carried out by Dimplex service personnel or its authorised dealer(s).
- Caused by use of any consumables or spare parts for your Dimplex product which are not Dimplex -specified.

Terms and Conditions

The Dimplex Warranty is valid for Dimplex from the date of purchase of your Dimplex product from a recognised retailer in the country of purchase and use, or the date of delivery of the product if later, always provided the original receipt has been retained and is produced as proof of purchase.

You must provide to Dimplex or its authorised agents on request the original receipt as proof of purchase and - if required by Dimplex - proof of delivery. If you are unable to provide this documentation, you will be required to pay for any repair work required.

Any repair work under the Dimplex Warranty will be carried out by Dimplex or its authorised dealer(s) and any parts that are replaced will become the property of Dimplex. Any repairs performed under the Dimplex Warranty will not extend the Warranty Period.

Any replacement of your Dimplex product by Dimplex during the Warranty Period will start the 3 year Warranty Period afresh from the date of delivery of the replacement Dimplex product to you.

The Dimplex Warranty does not entitle you to recovery of any indirect or consequential loss or damage including but not limited to loss or damage to any other property.

The Dimplex Warranty is in addition to your statutory rights as a consumer and your statutory rights are not affected by this Dimplex Warranty.

Contact Dimplex

A brand of the GDC Group Limited, trading as Glen Dimplex Heating & Ventilation

If you have any questions about what the Dimplex Warranty covers and does not cover or how to claim under the Dimplex Warranty, please contact us:

GDHV, Grange Drive, Hedge End, Southampton SO30 2DF

Telephone: 0344 879 3588

Email: customer.services@glendimplex.com

Visit: www.dimplex.co.uk