

## INLINE INSTANTANEOUS WATER HEATER



### Product Description

A compact 6kW under basin instantaneous inline water heater. Simple to easy to install, quick response water heating at point of use, ideal for hand washing and light dishwashing duty.

### Key Features

- Instant water heating at point of use, always available with no stored heated water or wasted energy
- Compact under or adjacent to basin mounted unit
- 6kW high efficiency heating elements for rapid response hand washing
- No controls - hot tap activated at 2 Litres per minute flow
- Fully temperature stabilised with 80°C thermal cut-out safety protection
- Pre-wired with 700mm length of 4mm<sup>2</sup> double insulated 3 core cable ready for connection
- Suitable for use with water resistivity  $\geq 1300\Omega\text{cm}$
- Use with M22/M24 quarter turn spray head basin taps is recommended for optimum performance

### Application Exclusions

- Not compatible with thermostatic mixer taps
- Not suitable for supplying a bath or for heavier duty dishwashing

### Range Details

Item Code:	Model No:	Description	kW
067395	RIWH6	Inline instant water heater	6

### Dimensions

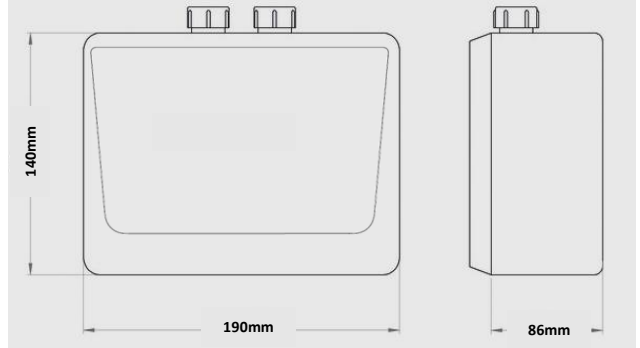

### Technical Details

Model	RIWH6
Item Code	067395
EAN /Bar Code No.	5011139067395
Output (kW)	6
Current Rating (Amps)	27
Energy Rating (Class)	A
Energy Rating (%)	39
Consumption (kWh/annum)	458
Load Profile	3XS
Sound (dB)	15
Operating Pressure (psi/bar)	(15/1) - (108/7.5)
Thermal cut-out temperature	80°C
Activation flow rate (Ltr/min)	2
Maximum flow rate (Ltr/min)	3.3 (1bar) 7.9 (5bar)
Water connections	½" BSP
Required water resistivity	$\geq 1300\Omega\text{cm}$
IP Rating	IPX4
Approvals / Mark	BEAB & CE
UK Warranty (years)	1

## INLINE INSTANTANEOUS WATER HEATER

### Power and Water Connectivity

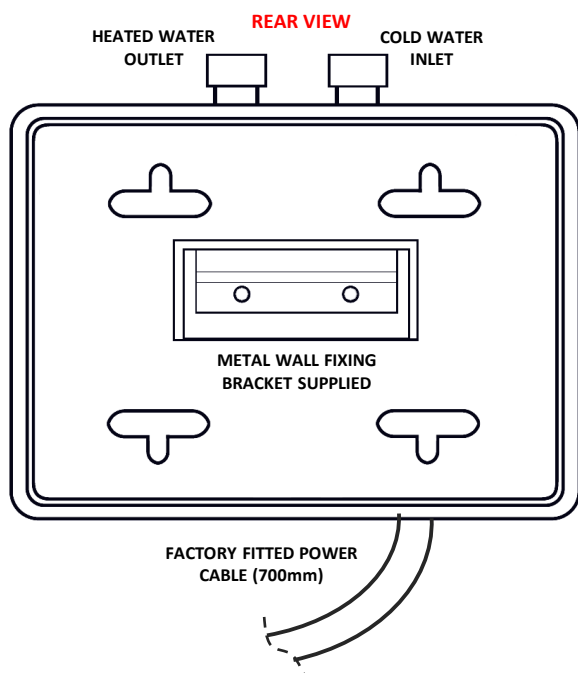

**Not suitable for use with thermostatic mixer taps**

### Pack Contents

- 1 x 6kw Instant water heater
- 1 x Wall Bracket
- 1 x Gauze inlet filter fitting
- 1 x Screw and wall plug fixing pack
- 1 x ErP energy rating label
- 1 x Installation and user instruction manual

### Materials

- Durable ABS casing (White)
- Fast response bare wire nickel chrome heating elements

### Product Packaging & Waste Data

Model	RIWH6
Item Code:	067395
Single unit pack dimensions (mm)	205 x 220 x 112
Single unit packaged gross weight (Kg)	1.69
Single unit net weight (Kg) unpacked	1.56
Single unit carton weight (Kg) cardboard	0.15
Transit box containing 6 units (mm)	390 x 465 x 265
Pallet total quantity (single units)	216

### Certification

BEAB Approved (Ref)	Yes
WRAS	Approved Materials
CE Marked	Yes
Country of Origin	China

Temperature Rise (°C)

