

Square Portable Solar Light

Installation instructions

JCC | a **LEVITON** company

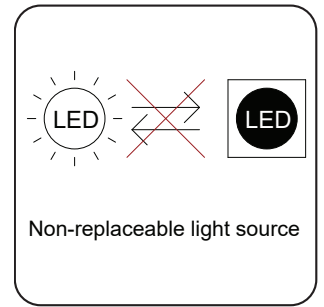

Warnings & Cautions

- Do not install in areas that are exposed to continual running water or prone to flooding.
- Ensure that the mounting surface is both flat and stable.
- Any broken or damaged parts should be replaced as soon as possible.
- JCC will not accept responsibility for claims arising from sub-standard installations
- These products are suitable for indoor and outdoor use.
- This product is battery powered and they are charged via the solar panel, it can also be charged using a 5VDC mains adapter plug and USB charging lead supplied.
- Only the supplied mains adapter plug and USB lead should be used for charging
- The batteries in this product are rechargeable and must only be replaced by a competent person.



INSTALLATION

ENGLISH

Specifications Colour temp: 3000K Ra: 84 (Class II  Plug Adapter, Class III  Solar light)

Product code	Wattage	Lumens	Mains USB Charging Time	Solar Charging Time	Maximum run time
JC17065	3W	238	6-7 hrs	16-17 hrs	9 hrs

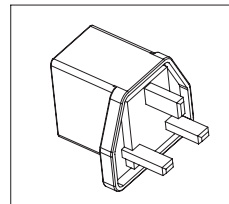

Mains USB Adapter:
100-240V~ 50/60Hz
5V  1A

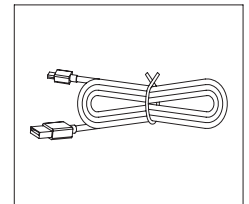

Micro USB Lead:
1.2 metres

1. Prior to use, ensure that the product is fully charged
2. Connect the micro USB lead to the charging port by removing the silicone protective cover (Fig.1). Using the supplied Mains Adapter, connect the USB lead to the mains supply (Fig.2).
3. When the mains supply is connected the Touch Switch (Fig.3) will turn red. Once fully charged, the Touch Switch will turn green. (Note: the Batteries have built in over-charge protection)

4. Operation of Touch Button:

1. Single Touch: on or off
2. Press/Hold when on: Light increases gradually (release button when light level is achieved.)
3. When on, press for more than 4 secs (100% light output)
5. When on, single Touch fades light to off

Fig.1.

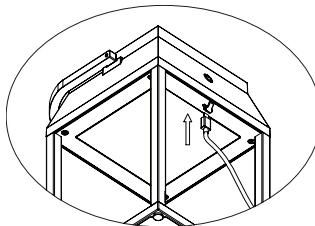

Fig.2.

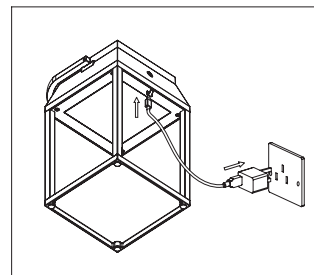
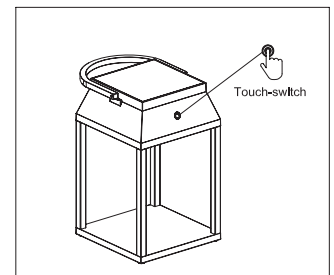

Fig.3.



General Maintenance Requirements

JCC Lighting Products recommends that this product is cleaned with warm water and dried with a chamois leather or absorbent dry cloth. Weathering, environmental pollution and bird droppings should be cleaned off with a non-abrasive cleaner. This is to ensure that the solar panel is fully effective in charging the batteries, and to preserve the finish of this product.

You can help protect the environment. Please remember to respect the local regulations: hand in the non-working electrical equipment to an appropriate waste disposal centre. The packaging material is recyclable. Dispose of the packaging in an environmentally friendly manner and make it available for the recyclable material collection service.

CE UK  RoHS Compliant IP54 **jcc.co.uk**

Important warranty information

This product is supported by a 2-year standard warranty which will extend to 3 years if registered within the first year of purchase. (2 year on batteries). Please register at jcc.co.uk/warranty - Terms and conditions apply.

The installer will be asked to provide the following information, which is detailed on a label attached to the luminaire's chassis: Product Code/Date Code.

Square Portable Solar Light

Replacement of Batteries:

1 x SPR017002- 2 x 3.7V 18650 2200mAh Lithium battery

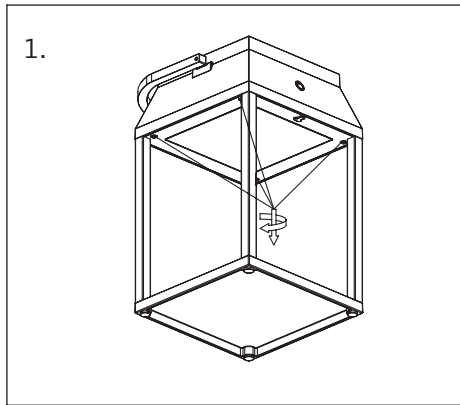

1. Remove the 4 screws as indicated above to release the top of the body

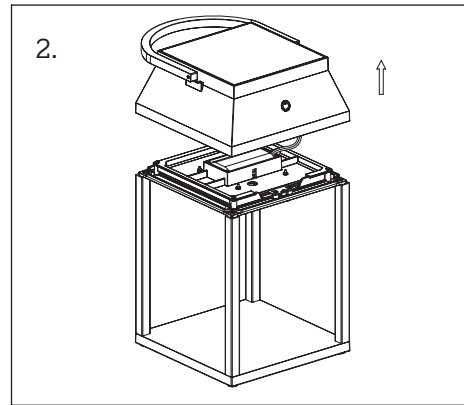

2. Disconnect the battery lead from the top of the body

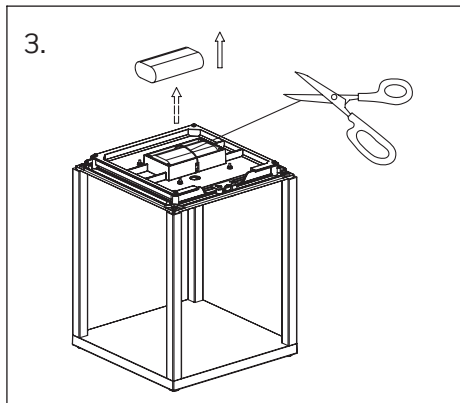

3. Remove the battery restraint and remove the battery from the body

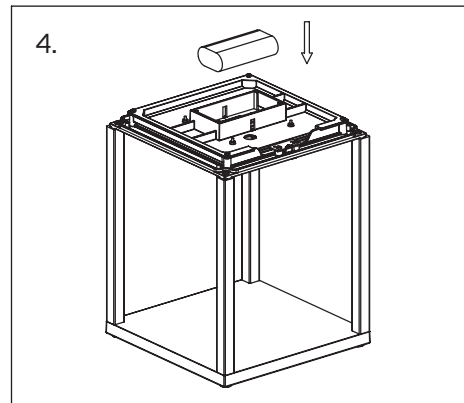

4. Fit the replacement battery and resecure with a suitable restraint

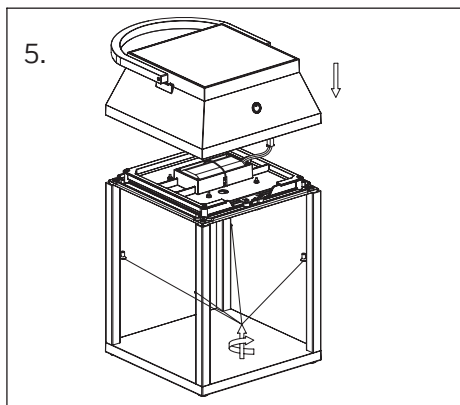

5. Reconnect the battery lead to the top of the body, then locate the head to the body and refit the 4 screws

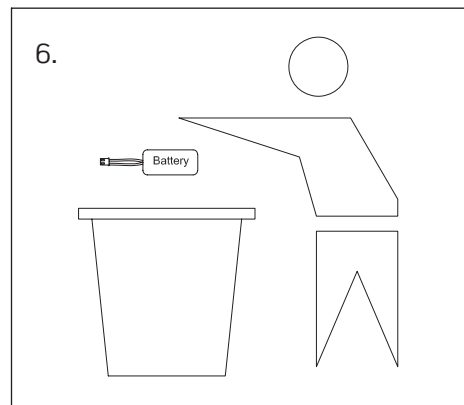

6. Please hand in the non-working battery to an appropriate waste disposal centre, do not dispose of with household waste

Prior to use after replacing the batteries, ensure that the product is fully charged.

Please refer to points 1-3 in the installation instructions.

