

## DATASHEET

### Image



### General Information

Product:	12.031
Description:	15mm Angled TRV & lockshield valve
Website Link:	<a href="#">(Click Here)</a>
Product Type:	Radiator Valve
Brand:	Eastbrook Company
Colour:	Brushed Nickel
Height (mm):	127.3mm
Net Weight (kg):	0.437kg
Product Range:	Radiator Valves

### Product Specifications

Warranty:	2 Year(s)
Valve Types:	Angled

## Drawing

### Eastbrook

Angled Thermostatic Radiator Valve & Lockshield  
Technical Drawing

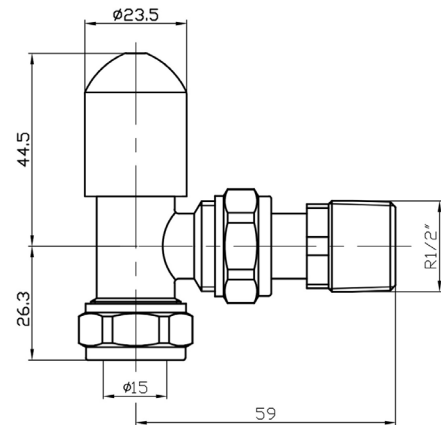
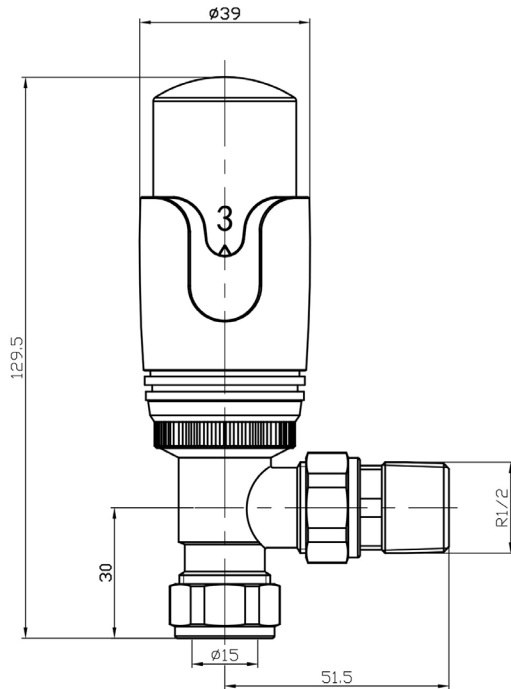

12.047  
12.041  
12.031  
41.3036  
41.3023  
41.3027  
41.3029  
41.3024  
41.3025  
12.076  
12.079  
12.085

**Eastbrook**   
Eastbrook Road, Gloucester GL4 3DB  
Technical Helpline : 01452 317890  
Mon - Fri / 8am - 5pm  
Email : [technical@eastbrookco.com](mailto:technical@eastbrookco.com)