

# Installation instructions and cautions

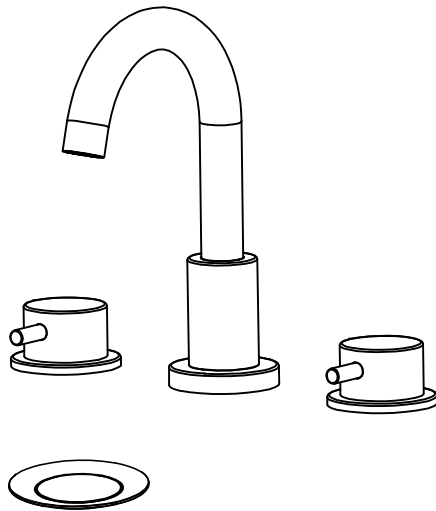

The instruction fits 3 holes basin tap with pop-up waste.

## Cautions

1. Clean the pipes before installation.
2. Check the pipes for breaks.
3. The pressure to work on the tap is within 0.05-1.0 MPa.
4. Water supply temperature maximum less than 90 degrees, suggested temperature less than 65 degrees.

## Mounting Dimensions

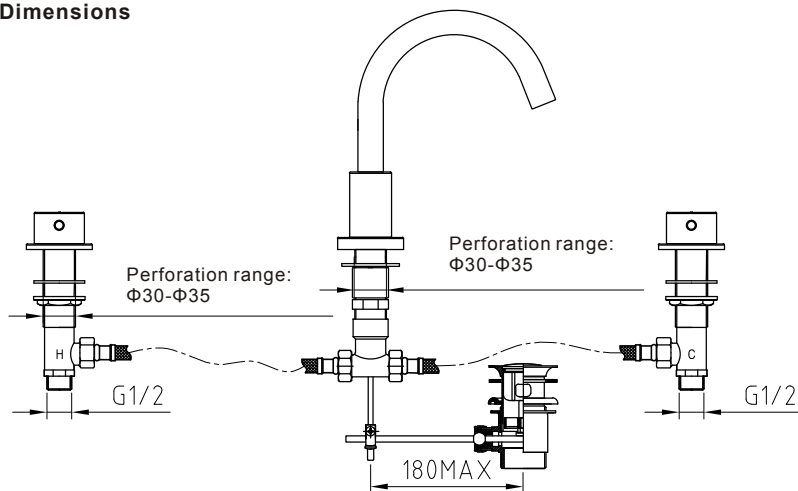

## Installation steps

### 1. Installation of the valve body

(1) Remove the handle (NO. 1) from the hand wheel (NO. 3), unscrew the screw (NO. 2) with Allen key, then remove the hand wheel (NO. 3), flange (NO. 4) and rubber gasket (NO. 5) from the valve body.

(2) Install the valve body through the mounted hole on the basin, attach the flange (NO. 4) and rubber gasket (NO. 5) on the valve body, tighten the nut (NO. 6) with wrench, ensure that the valve body does not shake, then attach the hand wheel back on the valve body.

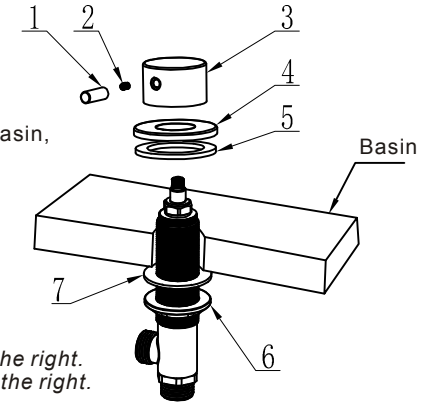

The same way to install the another valve body.

### Note that:

Hot water valve body on the left, cold water valve body on the right. The direction of the handle switch refers to the diagram on the right.

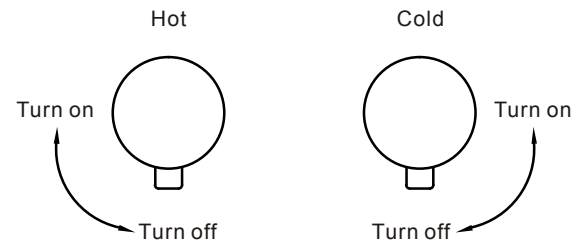

### 2. Installation of the tap body

(1) Remove the gasket (NO. 8), the pipe (NO. 9), the nut (NO. 10) and the inlet tee (NO. 11) from the tap body.

(2) Install the tap body through the mounted hole on the basin, attach the gasket (NO. 8), the pipe (NO. 9), the nut (NO. 10) and the inlet tee (NO. 11) back on the tap body, tighten the nut (NO. 10) with wrench, ensure that the tap body does not shake.

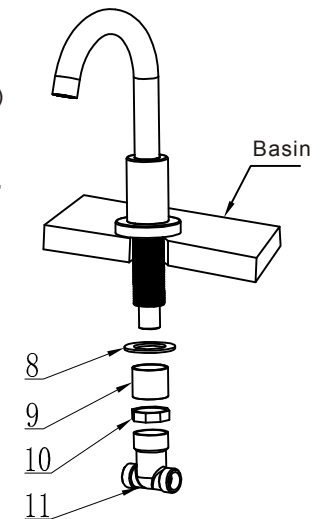

### 3. Installation of the waste

(1) Remove the sealing combination (NO. 12), flange (NO. 13) and the waste (NO. 14) then remove the nuts (NO. 15) and plastic ring (NO. 16) from the waste.

(2) Connect the flange (NO. 13) from the top of the basin with the waste (NO. 14) from the bottom of the basin through the mounting hole, then tighten them.

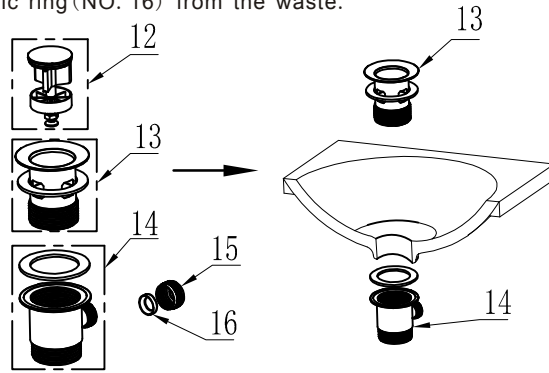

### 4. Installation of the pop-up rod

(1) Remove the converted joint (NO. 17) from the connecting rod, then install the nuts (NO. 15) and plastic ring (NO. 16) on the connecting rod, last install the converted joint back to the connecting rod.

(2) Install the lifting rod (NO. 18) through the hole in the basin tap, connect the lifting rod with the converted joint on the connecting rod, tighten the nut (NO. 15), then tighten the screw (NO. 17) on the converted joint.

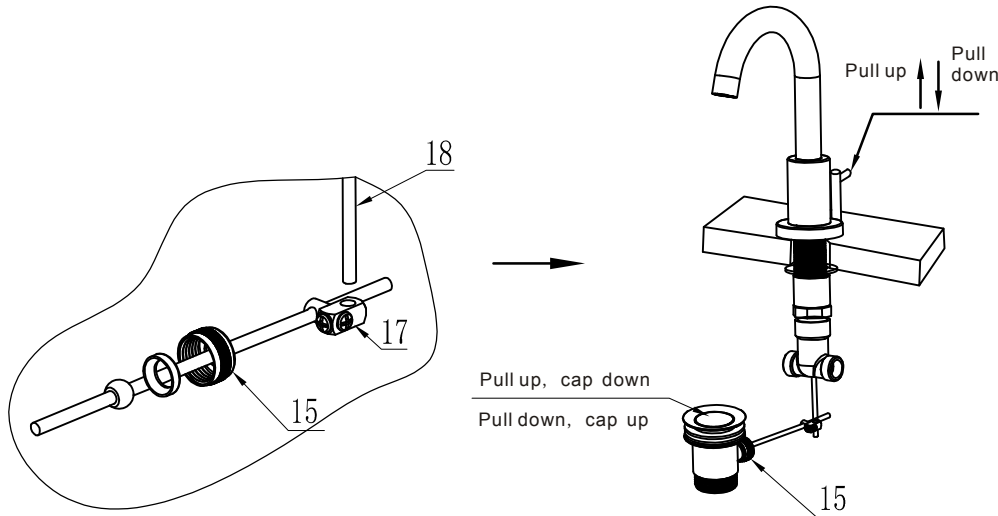
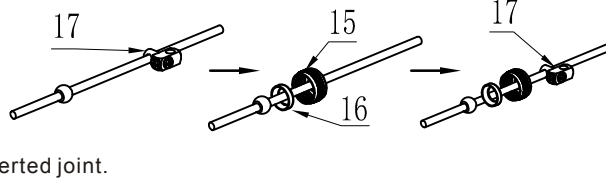

### 5. Installation of the connection pipe

Connect the valve body and tap with hose (NO. 19), after the connection of two valve body with the tap, connect the hot water inlet pipe with hot water valve, connect cold water inlet pipe with cold water valve.

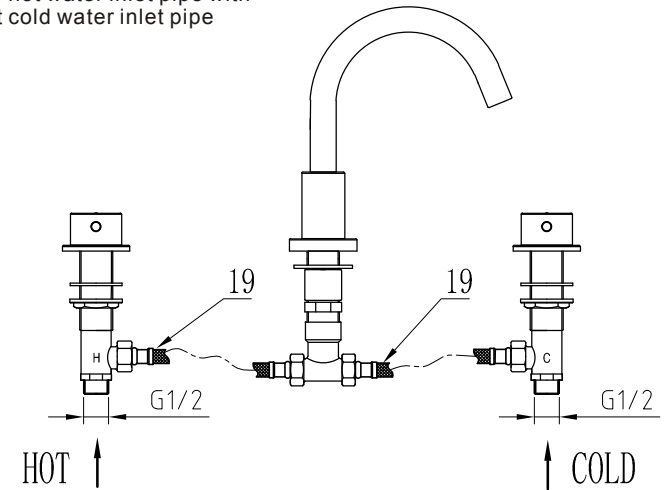

### 6. Installation check

(1) After the installation is completed, check connected parts to see if they are firmly installed and the screws are locked.

(2) Open the water supply valve and check whether there is any leakage in each connection part.

(3) Remove the aerator (NO. 21) with specialized wrench (NO. 20), turn on the valve allow the water to run for one minute, flush the contaminants in the pipe.

(4) Turn off the valve, put the aerator (NO. 21) on.

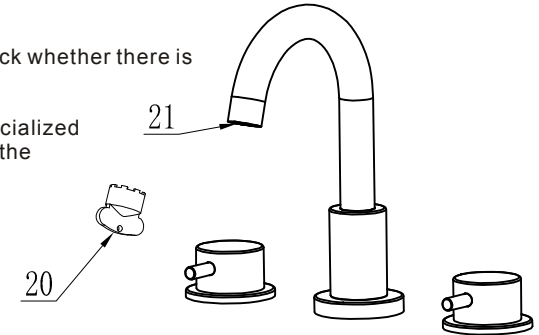

### Cleaning instructions

(1) It is recommended to clean with soft cotton cloth or sponge.

(2) Do not use any aggressive liquids for cleaning, such as ammonia, decontaminated water, toilet bowl cleaner, etc.

(3) Do not use metal or hard cleaning tools such as cleaning balls to wipe the surface of the tap.