

DATASHEET

Image



General Information

Product:	41.3039
Description:	15mm Angled TRV and Lockshield Valve
Website Link:	(Click Here)
Product Type:	Radiator Valve
Brand:	Eastbrook Company
Colour:	Chrome/Gloss White
Material:	Brass + Plastic
Net Weight (kg):	0.41kg
Product Range:	Radiator Valves

Product Specifications

Warranty:	2 Year(s)
Valve Types:	Angled

Drawing

Angled TRV with Lockshield 15mm Technical Drawing

41.3039

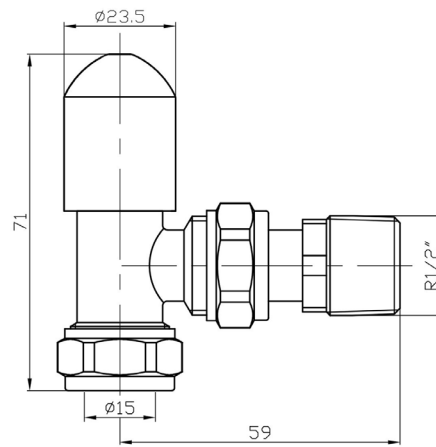
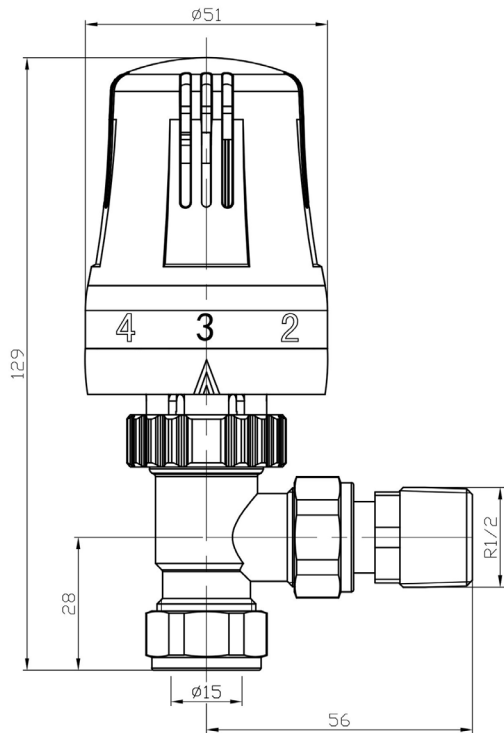

Eastbrook 
Eastbrook Road, Gloucester GL4 3DB
Technical Helpline : 01452 317890
Mon - Fri / 8am - 5pm
Email : technical@eastbrookco.com