

## IMPORTANT

Flush out all impurities in the cistern prior to installation.

### FILL VALVE - ASSEMBLY IN CISTERN

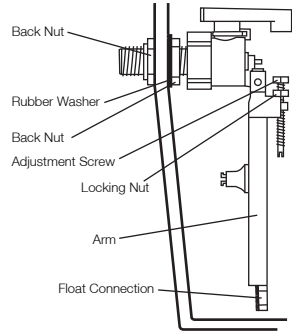

Screw the float into the swivel arm screw and assemble inside the cistern tank as shown. Check for free movement of the float (ensure the float does not get caught on the side/back wall of the cistern). To adjust the water level rotate the water level adjustment screw. Turn clockwise to reduce shut-off level, turn anti-clockwise to raise shut-off level, secure by hand tightening the locking nut.

Assemble the side entry inlet valve as shown.

### FLUSH VALVE - ASSEMBLY IN CISTERN

Ensure the flush valve is assembled and fully tightened as shown, making sure the rubber seal is over the thread of the valve and between the valve and the cistern. Make sure that the fill valve and flush valve are not touching when assembled inside the tank. Use PTFE tape around the thread to ensure a water tight seal as shown below.

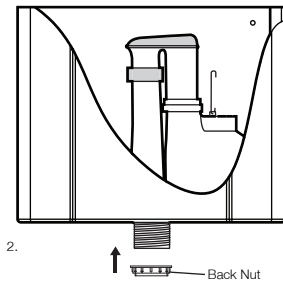
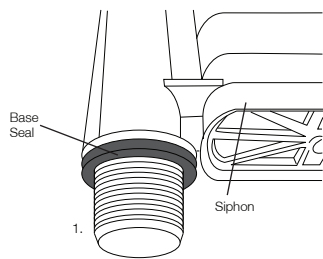

### FLUSH LEVER INSTALLATION

Assemble the flush arm to the tank. Attach the flush arm to the C-link on the flush valve using the first hole, as shown below. The handle and chain can then be attached to the flush arm.

1.

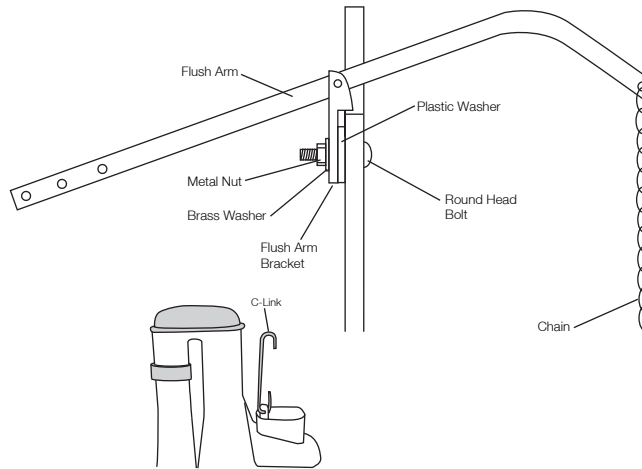

2.

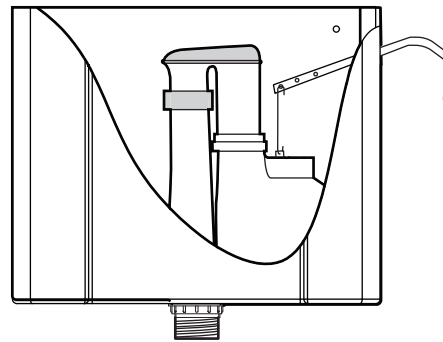

### ASSEMBLY INSTRUCTIONS

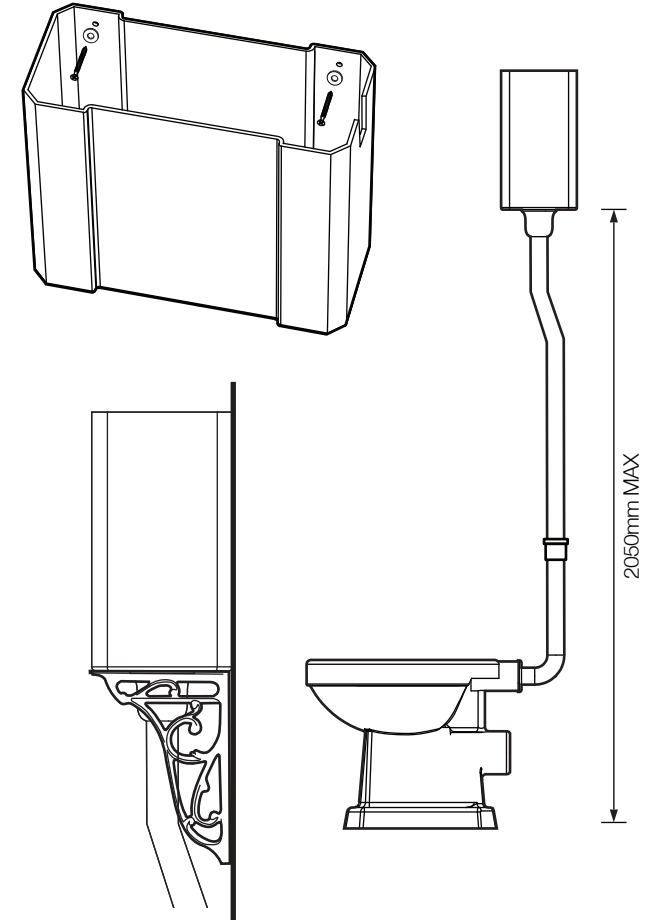

1. The underside of the cistern can be a maximum of 2050mm off the floor.

Fix the cistern brackets to the wall first. Put the cistern on top of the brackets and mark the positions of the holes on the wall. Screw the cistern to the wall using the fixing screws and washers supplied through the fixing holes in the back of the cistern. Ensure the tank is firmly secured to the wall. The high level pipe kit can be cut down if required.

Note: Any screws and plugs supplied are suitable for stone/brick walls only. If in doubt consult an expert.

## ASSEMBLY DIAGRAM

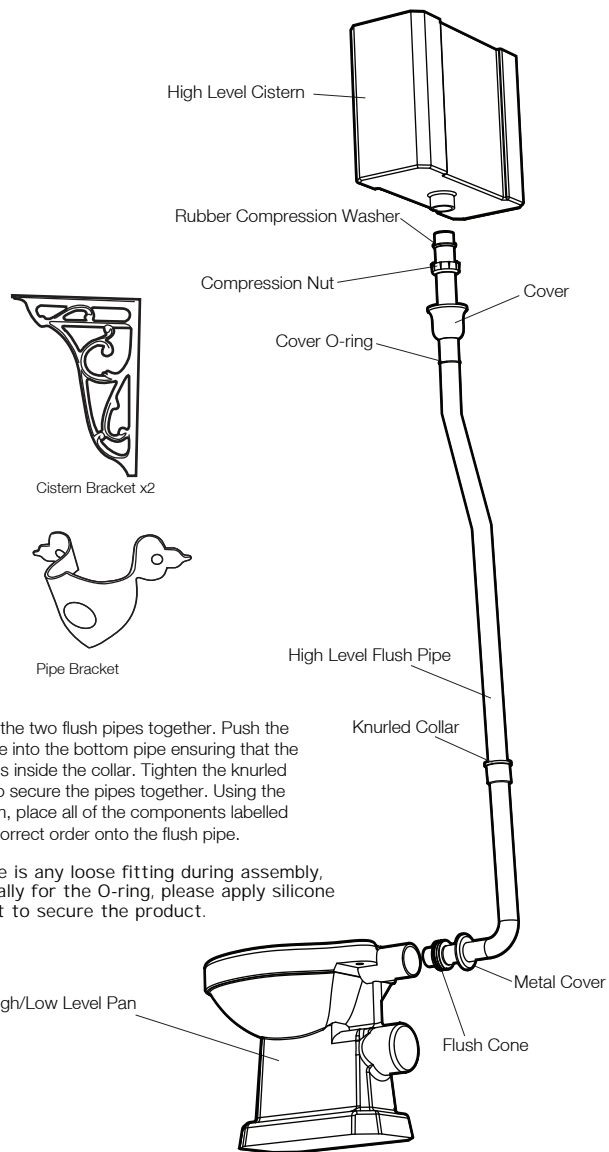

2. Join the two flush pipes together. Push the top pipe into the bottom pipe ensuring that the O-ring is inside the collar. Tighten the knurled collar to secure the pipes together. Using the diagram, place all of the components labelled in the correct order onto the flush pipe.

If there is any loose fitting during assembly, especially for the O-ring, please apply silicone sealant to secure the product.

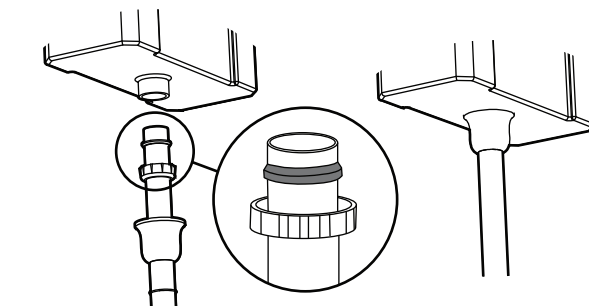

3. Insert the flush pipe into the bottom of the cistern and tighten the compression fitting. To ensure a good seal use PTFE tape, around the thread.

Move the cover over the base of the flush valve and move the O-ring so it stays in position.

If there is any loose fitting during assembly, especially for the O-ring, please apply silicone sealant to secure the product.

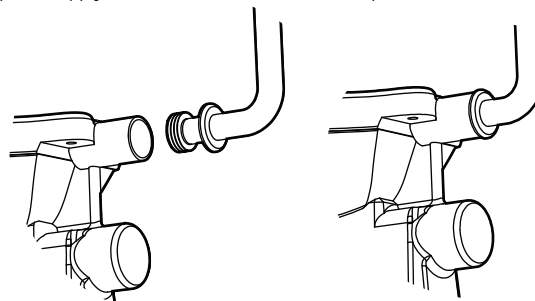

4. Insert the flush pipe and flush cone into the inlet hole on the pan. Ensure the pipe is fitted securely into the pan.

Use a small dab of silicone to hold the metal cover in place.

5. Use the pipe bracket to fix the pipe to the wall. Mount this bracket about halfway up the flush pipe.

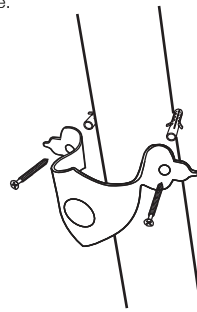

## MAKING PLUMBING CONNECTIONS

Connect the soil pipe and ensure it is adequately sealed around the toilet pan outlet to prevent leakage.

The inlet valve has a threaded connector. It is recommended that this thread is wrapped in PTFE tape before connecting the water supply.

NOTE: Connect the water supply to the cistern using an approved double check valve to fluid category 3 in addition to an accessible service valve.

Do not overtighten the supply to the inlet valve as this could damage the inlet valve causing leakage.

After connecting the water supply to the inlet valve check that the inlet valve components do not touch the internal walls of the cistern and the ball float can move freely up and down.

Check all connections are secure and a soil pipe is fitted before testing the flush.

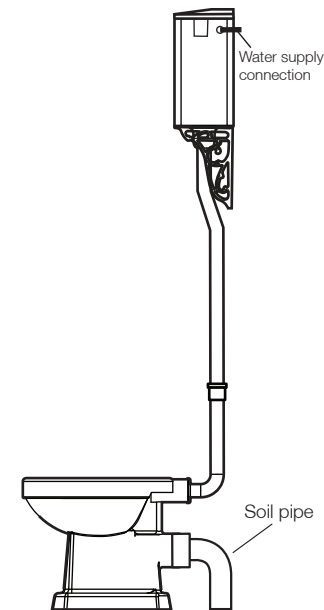

## FINAL COMMISSIONING

- Fill the cistern with water and carefully check for leaks.

- Test the overflow by holding the float down, ensure that incoming water is completely discharged. If not partially close the isolation valve (not supplied) and try again. Repeat until all incoming water is discharged.

- Check that the inlet valve shuts off on the water line indicated inside the cistern.

## OPERATION

Pull the handle on the chain for a full flush.

## CARE

DO NOT introduce caustic chemical substances (e.g. containing chlorine compounds or similar). These can damage the valve components and cause failure.