

1. Make sure to check your radiator for transport damages or any other type of damages after taking the radiator out of its box and before starting the below steps.
 2. Screw a blanking plug and bleed valve (air vent) into the top 2 threads in the top header of the radiator. Make sure to use PTFE tape (thick layer of at least 6 turns) on the blanking plug and bleed valve (air vent). Tighten firmly with a 22mm or adjustable spanner.
 - Tunstall radiators can accommodate only side entry plumbing. Make sure that the bleed valve (air vent) is at the top opposite side of the inlet at the bottom header.
 3. Wind a thick layer (at least 6 turns) of PTFE tape, clockwise around the radiator valve tails (not supplied with the radiator) and screw the radiator valve tails into the 2 threads at the bottom header then tighten with a spanner.
 4. The bottom of the lower wall brackets should be at least 100mm. above the finished floor level so that the bottom of the radiator is at least 150mm. above the finished floor level. Check that the wall is strong enough to hold the weight of the radiator. On plasterboard walls we strongly recommend fixing to the timbers. Mark your preferred wall bracket positions on the wall and drill holes for the fixings you intend to use. The wall plugs supplied are only suitable for solid walls and you will need alternative fixings for other wall types.
 5. Screw the wall brackets to the wall using the washers & wall screws provided or alternative fixings.
 6. Place the rubber bracket buffers into the curved seat in the wall brackets. Lift the radiator into position on the wall brackets.
 7. Connect the radiator valves (not supplied with the radiator) and fill the system to check for leaks and fix as necessary.
 8. Flush the entire system with a DWTA approved central heating cleanser and then refill using a DWTA approved central heating protector. (see page 2 for the necessary corrosion inhibitor details)
 9. Run the system up to full temperature and release any trapped air using the bleed valve (air vent). Check the radiator and surroundings thoroughly if the installation has been done correctly and there is no leakage.
- Installation is now finished.

Ancillary Components	
3	Blank Plug
1	Air Vent Plug
8	Wall Plug (a)
4	Wall Bracket (b)
8	Washer (c)
8	Screw (d)
8	Bracket Buffer (e)

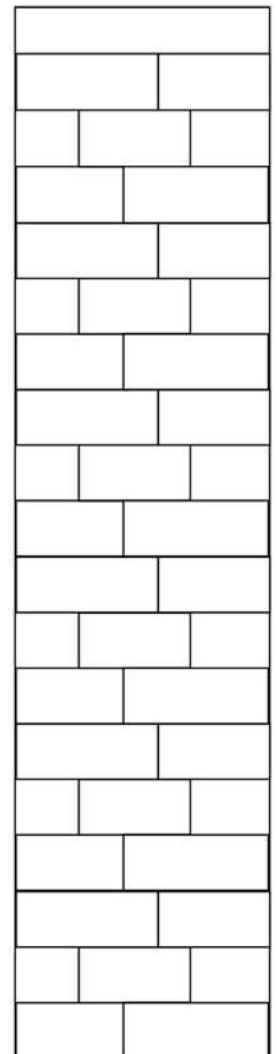
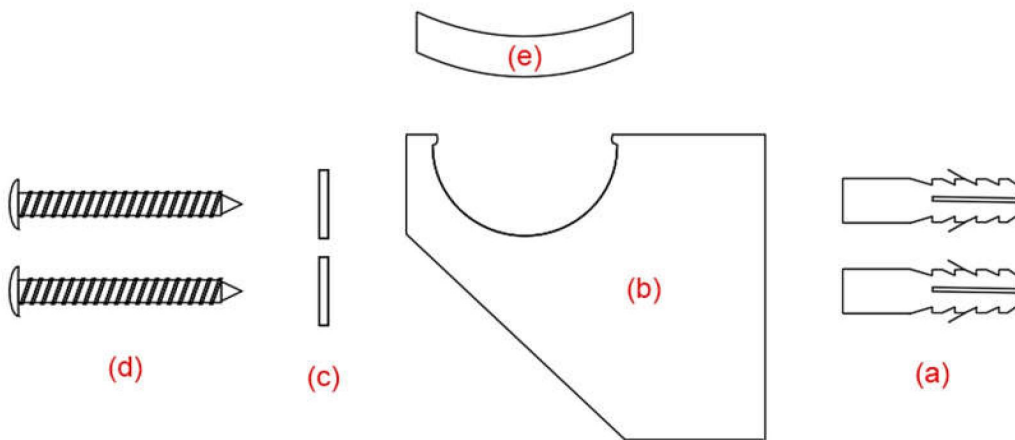

IMPORTANT NOTE

Maximum working pressure is 4 bar. This radiator is to be used on Domestic Heating Systems **only**. (Not suitable for use on direct hot water systems)

CONGRATULATIONS

You are the proud owner of an exclusive Tunstall Vertical / Horizontal Radiator which has been specially produced by our craftsmen who would wish you to enjoy many years of satisfaction from it.

INSTALLATION

This product must be installed by a fully qualified engineer.

- Please consider using an Eastbrook Valve Set – this will ensure that your radiator looks its best with matching radiator valves.
- On commissioning, flush the central heating system thoroughly using a proprietary solution to ensure that aggressive substances such as fluxes and manufacturing residue, from which internal surfaces of your radiator can sustain irreparable damage – are removed. It is further recommended that an appropriately approved corrosion inhibitor needs to be subsequently added to the heating system in order to protect the radiator and other parts of the central heating system to promote extended operating lifespan.
Please ensure, when adding inhibitor, not to underdose or overdose and follow the inhibitor instructions. The Ph level of the system water should be between 6.5 and 7.5
The inhibitor must not be based nitrate based!
Do not used softened water in your radiator!
Beware of own brand inhibitors!
Eastbrook recommends FERNOX F1 or equivalent inhibitor for your radiators.

MAINTENANCE

- From time to time, it is advisable to clean your towel rail with a warm damp cloth. Never use any form of abrasive cleaner or chemical.
- Corrosion inhibitor must also be regularly maintained, please consult your engineer for details.

IMPORTANT

- Maximum working pressure of this radiator is 4 bar.
- This radiator is to be used on Domestic Central Heating systems only. (Not suitable for use on direct hot water systems). Please consult your engineer or supplier.

WARRANTY

Your Tunstall Vertical / Horizontal Radiator has a manufacturer's warranty for five years in respect of defective materials and workmanship and subject to installation being carried out by a qualified engineer in accordance with good practice and the appropriate corrosion inhibitor being regularly maintained.

REMEMBER Excellence is worth looking after.