

DATASHEET

Image



General Information

Product:	54.0026
Description:	15mm Corner Dual Fuel TRV & Lockshield Valve
Website Link:	(Click Here)
Product Type:	Radiator Valve
Brand:	Eastbrook Company
Colour:	Matt White
Material:	Brass
Net Weight (kg):	0.825kg
Product Range:	Radiator Valves

Product Specifications

Warranty:	2 Year(s)
Valve Types:	Dual Fuel

Drawing

Dual Fuel TRV & Lockshield Valve Technical Drawing

54.0026 - 54.0027 - 54.0028

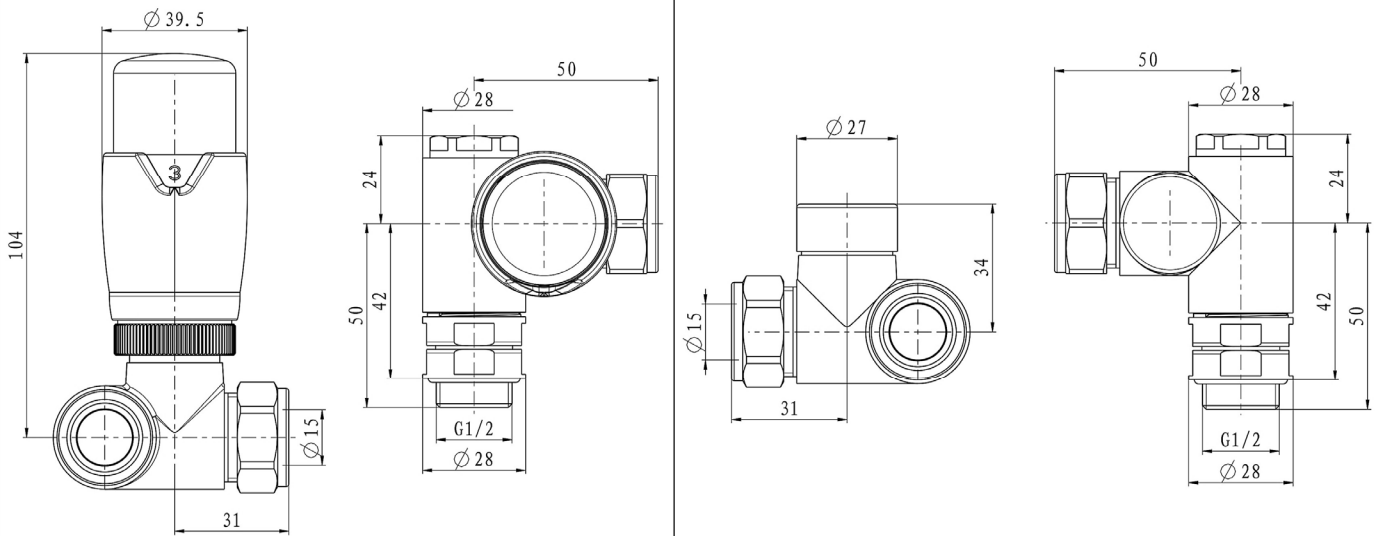

Eastbrook 
Eastbrook Road, Gloucester GL4 3DB
Technical Helpline : 01452 317890
Mon - Fri / 8am - 5pm
Email : technical@eastbrookco.com