

## DATASHEET

### Image



### General Information

Product:	33.0002
Description:	Margravine Freestanding bath 1660x730x570mm inc waste
Website Link:	<a href="#">(Click Here)</a>
Product Type:	Freestanding Bath
Brand:	Eastbrook Company
Colour:	Grey
Material:	Double skinned 4mm thick acrylic
Height (mm):	570mm
Width (mm):	730mm
Length (mm):	1660mm
Net Weight (kg):	38kg
Product Range:	Margravine

### Product Specifications

Warranty:	5 Year(s)
Water Capacity:	195L
Compatible Tap Types:	Floor or wall mounted
Pre-drilled tap holes:	No

## Drawing

Code No.: 33.0002  
Dimensions: 1660x730x570 mm

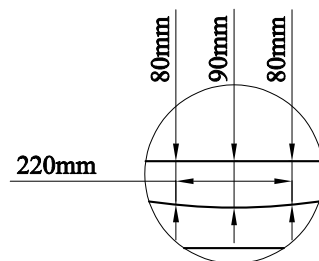
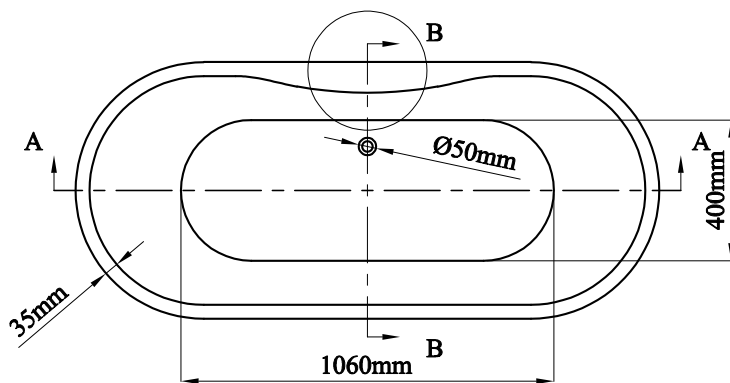
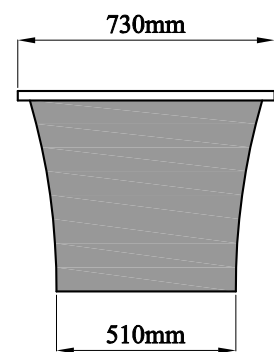
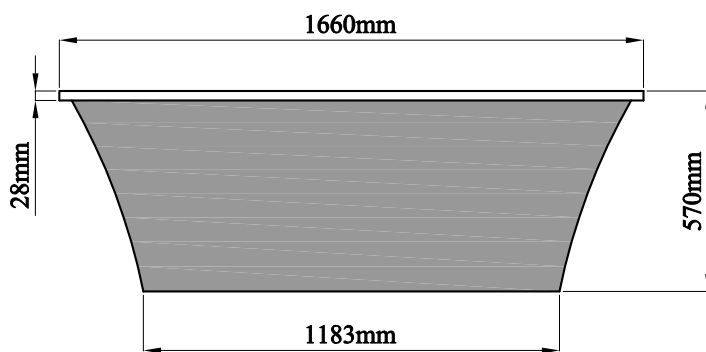

SECTION A-A

SECTION B-B

