

DATASHEET

Image



General Information

Product:	33.0026
Description:	Brockland 1600x750x570 Free-standing Bath
Website Link:	(Click Here)
Product Type:	Freestanding Bath
Brand:	Eastbrook Company
Colour:	White
Material:	Double skinned 4mm thick acrylic
Height (mm):	575mm
Width (mm):	750mm
Length (mm):	1600mm
Net Weight (kg):	35kg
Product Range:	Brockland

Product Specifications

Warranty:	5 Year(s)
Water Capacity:	230L
Compatible Tap Types:	Floor or wall mounted
Pre-drilled tap holes:	No

Drawing

Code No.: 33.0026

Dimensions: 1600x750x575 mm

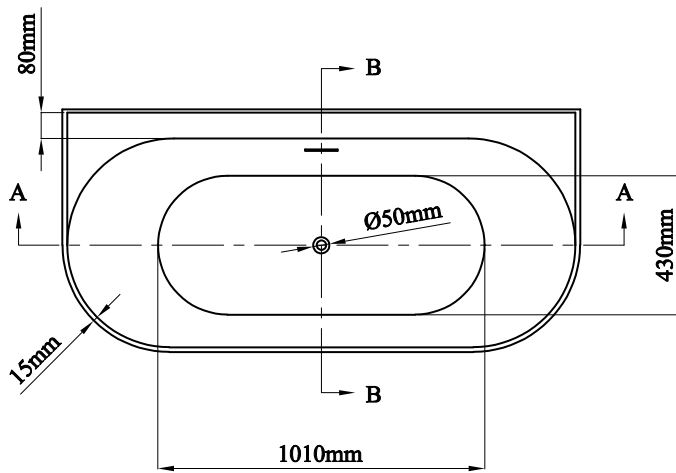
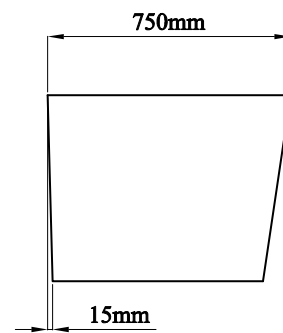
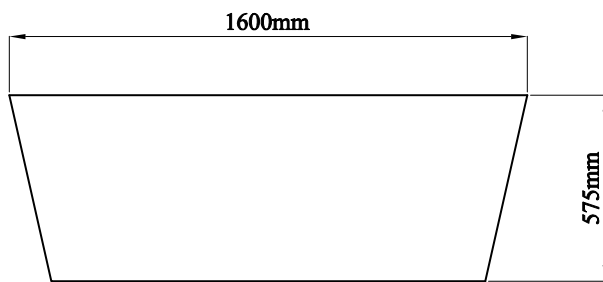

SECTION A-A

SECTION B-B

