

DATASHEET

Image

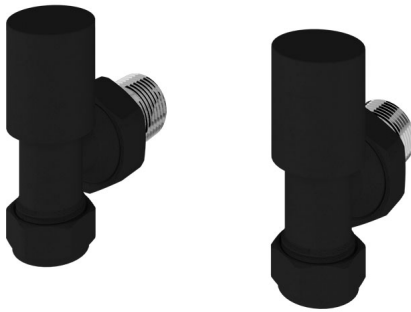

General Information

Product:	54.0046
Description:	Angled Radiator Valves (pair)
Website Link:	(Click Here)
Product Type:	Radiator Valve
Brand:	Eastbrook Company
Colour:	Matt Black
Height (mm):	14mm
Width (mm):	3.5mm
Length (mm):	9mm
Net Weight (kg) (kg):	0.45kg
Product Range:	Radiator Valves

Product Specifications

Warranty:	2 Year(s)
Valve Types:	Angled

Drawing

