

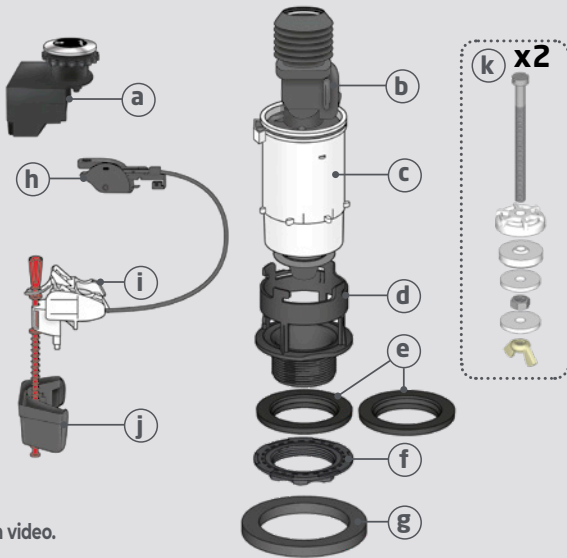

Scan to watch the installation video.



### PREPARATION

Turn off the water supply and empty the tank.

Check that the base of your old flush valve **d** is the same as the new one.

Case n°1: If it is different, remove the cistern from the pan and proceed to step 1.

Case n°2: If your old mechanism has the same base **d**, remove the top part by 1/4 turn anti-clockwise. Set aside parts **d**, **e**, **f**, **g** of your new flush valve. Proceed to step 1 below, then secure the new mechanism by 1/4 turn, then proceed directly to step 4.

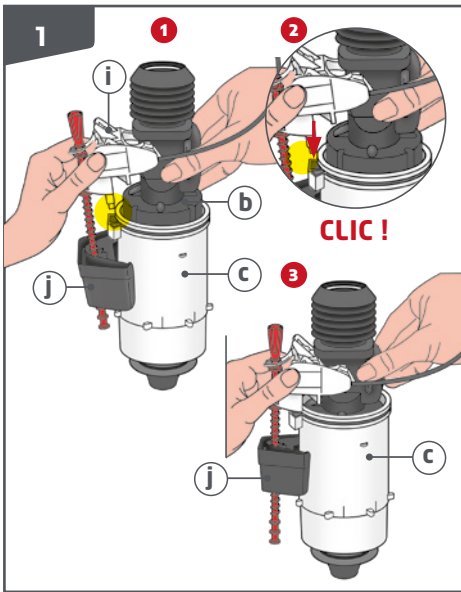

**ATTACHING THE FLOAT :** Position the float **1** as shown in the diagram and the fork **1** on the narrow side of the overflow **b**.

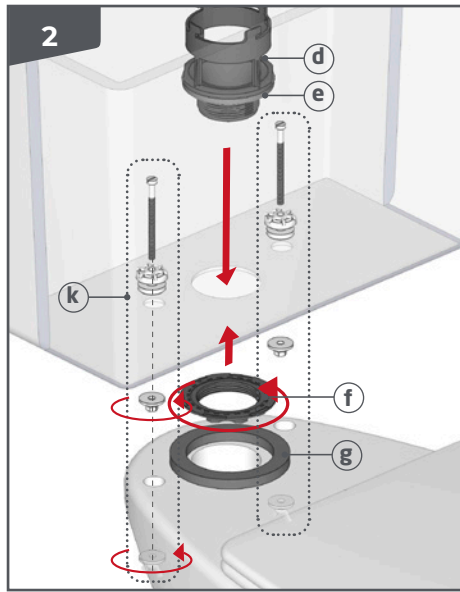

**ATTACHING THE BASE :** Place **d** and **e** at the bottom of the tank. Tighten the nut **f**. Center **e** on the basin. Secure the tank with the screws **k**.

**NOTE :** For a 1 1/2" outlet hole use the thin base seal washer **e** and for a 2" outlet hole use the thicker base seal washer **e**.

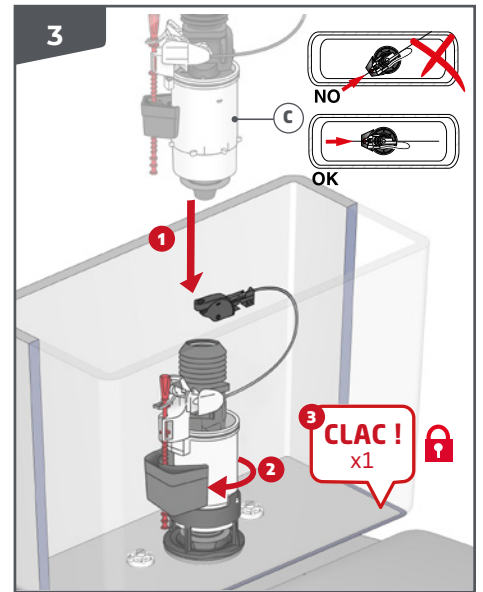

**ATTACHING CISTERN TO PAN :** Centre the close coupling washer **e** on the pan. Lower the cistern onto the pan ensuring the washer **e** stays in place. Secure the cistern in place with bolts **k**, tighten until there is no movement between the cistern and pan.

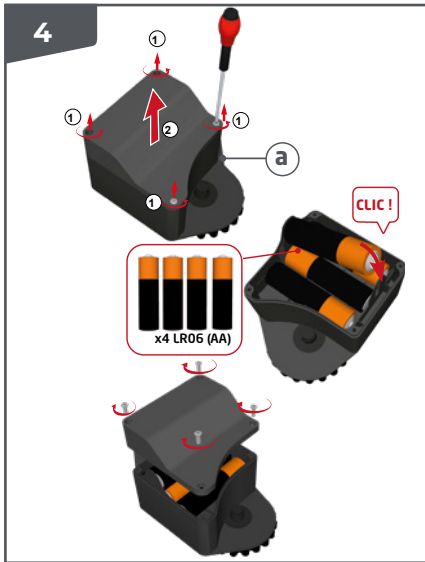

INSTALLING THE BATTERIES : remove the screws, insert the batteries and close, securing the cover with the screws.

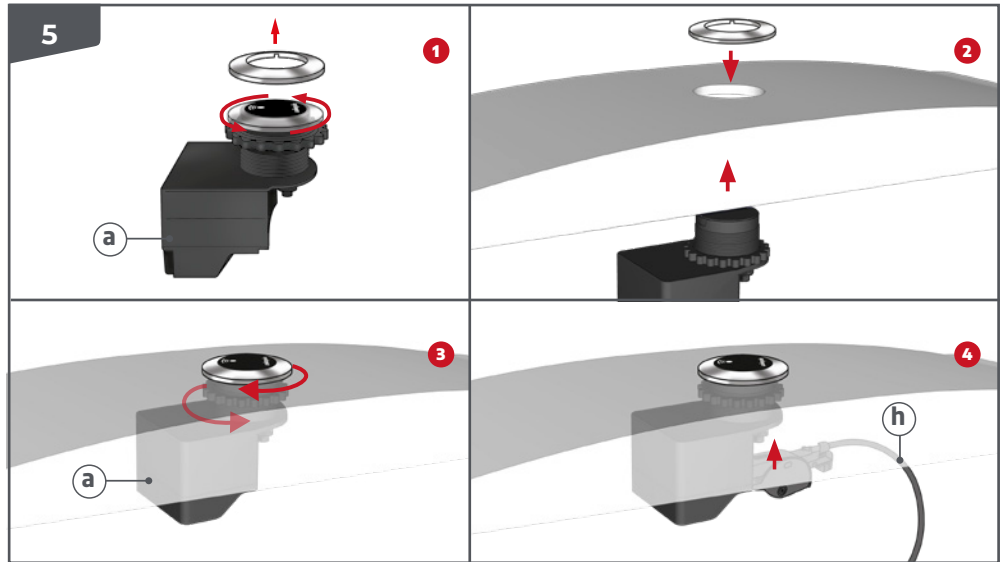

INSTALLING THE SENSOR (a): 1 Unscrew the chrome fascia by rotating anti-clockwise. 2 Position the sensor through the cistern lid. 3 Replace the chrome fascia by rotating clockwise 1/4 turn. Secure in place with the nut. 4 Clip the cable mechanism to the sensor.

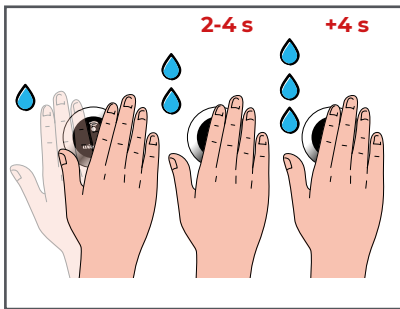

**x5**

The red LED flashes 5 times for 20 seconds: the system has detected a fault and resets itself. If the problem persists, check the installation.

**x3**

The red LED flashes 3 times for 20 seconds: the battery level is low.

The red LED stays on: the batteries need changing.

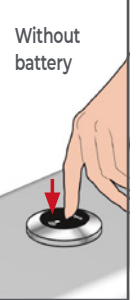

### FINAL COMMISSIONING :

To ensure that the overflow is capable of discharging the incoming water - hold the inlet valve down, causing the cistern to internally overflow. If necessary, reduce the flow of the incoming water by partially closing the isolation valve (not supplied).

### FACTORY-SET :

The flush valve is factory-set for optimum use, so there's no need to change the settings.

However, if you wish, the procedure is as follows:

To set the full flush: the higher the float ①, the lower the volume of water flushed. Use the red adjusting rod **a** to adjust.

The part flush setting is made by adjusting the height of the float.



In accordance with The Waste Electrical and Electronic Equipment Regulations 2013, items displaying the «crossed-out wheeled bin» symbol must not be disposed of with household waste. It can be taken to an appropriate collection point or returned to the distributor. By respecting these measures, you are doing your bit for the environment and helping to protect the environment.

