

DETAIL A

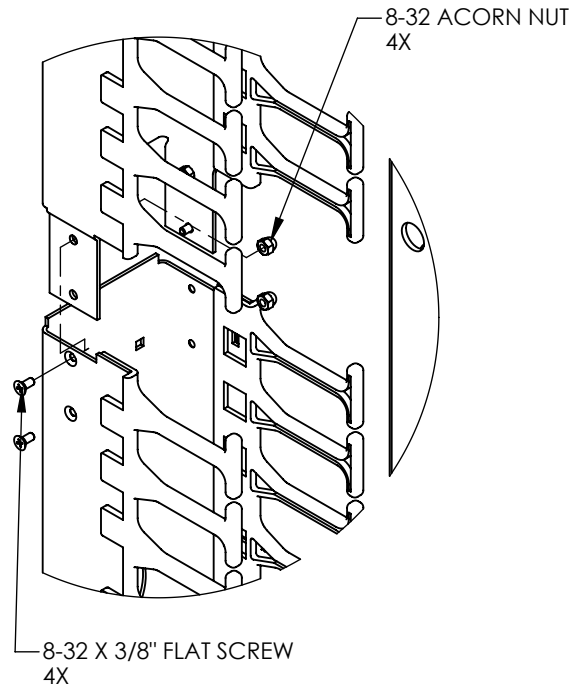

DETAIL B

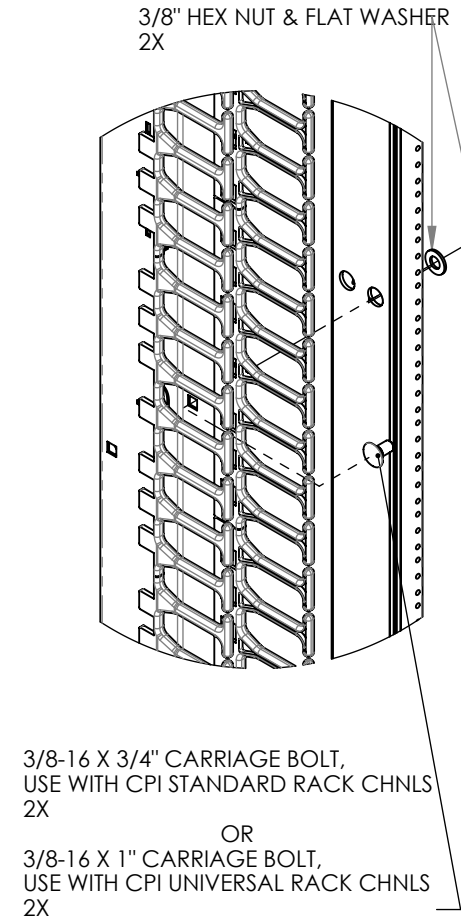

1. Lay top and bottom channels on clean flat surface, with plastic fingers facing upward. Slide units together as illustrated in Detail A.
2. Assemble top and bottom using (4) screws and (4) nuts. (See Detail A)
3. Vertically align to rack web surface.
4. Attach the unit to rack(See Detail B). Rack illustrated is CPI 19" X 7' Standard Rack. The unit can be mounted to all CPI Racks&Quadra Racks.

CPI CHATSWORTH PRODUCTS, INC.

INSTALLATION INSTRUCTIONS
GLOBAL VCS

THIS DRAWING CONTAINS INFORMATION PROPRIETARY TO CHATSWORTH PRODUCTS, INC. ANY REPRODUCTION DISCLOSURE OR USE OF THIS DRAWING IS EXPRESSLY FORBIDDEN EXCEPT AS AGREED TO IN WRITING BY CHATSWORTH PRODUCTS, INC.

DOOR COVER ASSEMBLY

Insert plastic hinges (4X) into each door as shown below.

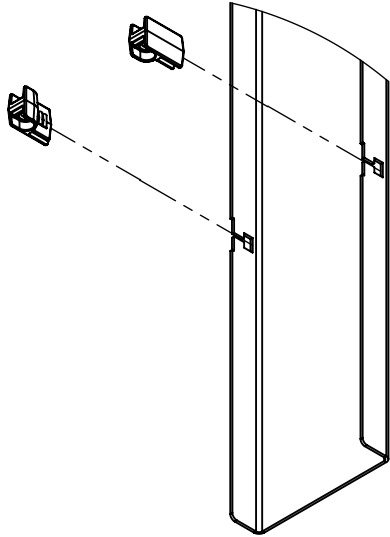

ATTACH THE COVERS

After aligning hinges over gaps between cable guide fingers, press inward on the cover until hinge snaps in place.

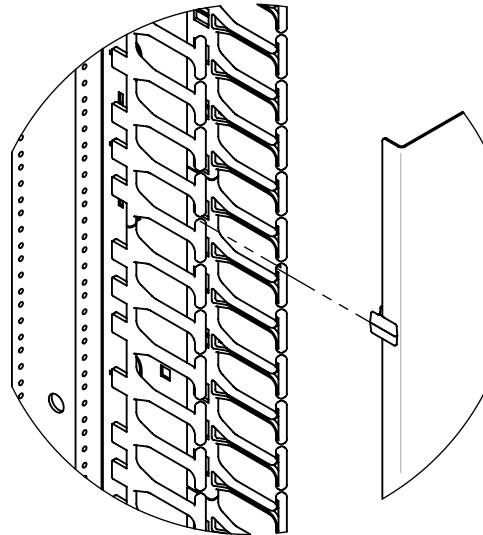

DETAIL C

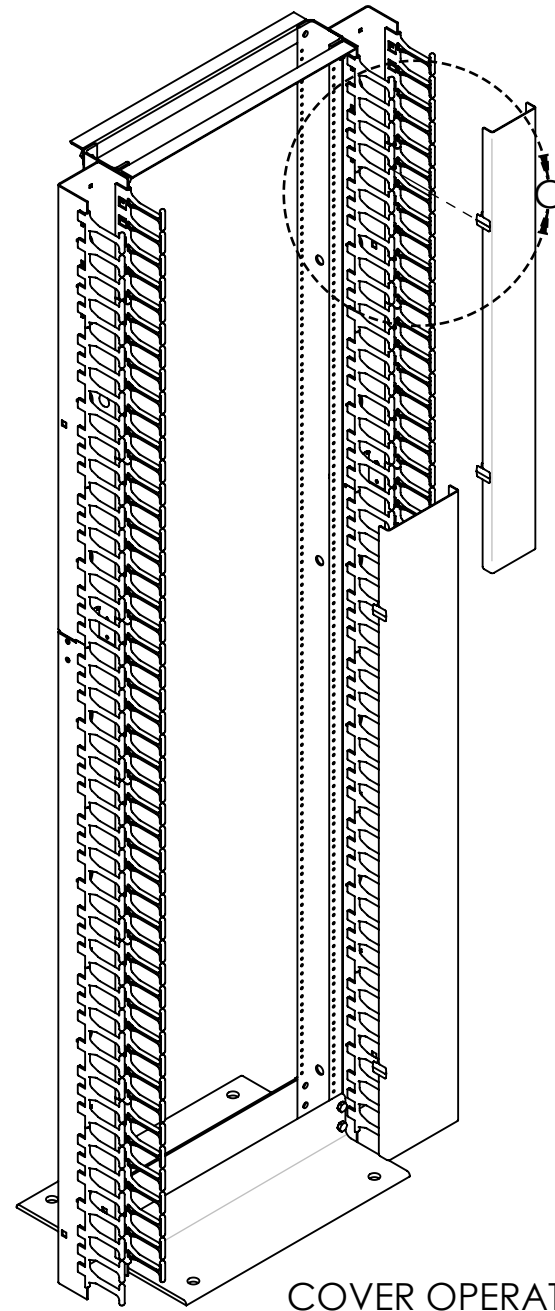

COVER OPERATION

To gain access to the cables, the cover can be hinged open, either from the left or right, or it can be completely removed.