

2' X 2' FIBER ENCLOSURE for Raised Floors

KEY FEATURES

- Raised floor enclosure fits under a single 2' x 2' raised floor tile; two sizes available
- Centered or offset 19" EIA threaded equipment mounting brackets with 4U or 6U of rack-mount space provides support for fiber enclosures and can facilitate angled patch panels.
- Use the raised floor enclosure in an air-handling space. Cables enter the enclosure through two integrated cable ports that seal with included foam sealing kits.
- Cable tie points within the enclosure allow easy management of cables.
- Adaptable for use with standard fiber cassettes (modules)

APPLICATIONS

- Create an architectural space under a raised floor that can store and secure a rack-mount fiber enclosure.

USE WITH

- Saf-T-Grip® Cable Management Straps
- Combination Pan Head, Pilot Point, Mounting Screws
- KoldLok® Raised Floor Grommet



2' x 2' Fiber Enclosure for Raised Floors

Cable tie point

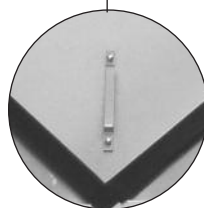

Prepare your data center for future changes by pre-wiring it with fiber connections between the core switches and each row of cabinets.

Raised floor enclosure provides easy access to a rack-mount fiber enclosure when it is located under a raised floor. Placing connections under the raised floor saves valuable rack-mount space within equipment cabinets, and allows the data center to be easily reconfigured — just unplug the patch cords and move the cabinet.

Raised floor enclosure is placed under a 2' x 2' raised access floor tile. Two sizes are available: 8"H (200 mm) or 12"H (300mm). Each enclosure includes a set of four brackets which supports the enclosure from the surrounding raised floor pedestals. The enclosure is adjusted in height to match the level of the floor. The floor tile becomes the top of the enclosure. Use KoldLok® Raised Floor Grommet to seal cable access holes in floor tiles.

Inside the enclosure, a pair of vertical 19" EIA equipment mounting brackets provide 4U or 6U of support for rack-mount equipment, specifically, a rack-mount fiber enclosure. The brackets can be attached at center or offset 4" (100 mm) of center and can be removed with equipment attached for easy access to connections.

The enclosure is UL Listed for use in air-handling spaces. Cables enter the enclosure through two cable ports that include foam sealing kits. There are four cable tie points on the bottom of the enclosure. Use Saf-T-Grip® Cable Management Straps to secure cables in the enclosure.

See reverse for product selection. Contact CPI technical Support for configuration assistance.



SPECIFICATIONS

- Raised floor enclosure with mounting brackets for a 19" EIA rack-mount fiber enclosure
- For indoor use only, in environmentally controlled areas; may be used in an air-handling space; may not be used outdoors, in industrial or harsh environments
- Size:
 - 4U, 24"W x 24"L x 8"D (610 mm x 610 mm x 200 mm)
 - 6U, 24"W x 24"L x 12"D (610 mm x 610 mm x 300 mm)
- Usable interior space:
 - 4U, 21"W x 21"L x 8"D (530 mm x 530 mm x 200 mm)
 - 6U, 21"W x 21"L x 12"D (530 mm x 530 mm x 300 mm)
- Cable access:
 - 4U, (2) 7" x 2" ports (180 mm x 50 mm)
 - 6U, (2) 10" x 2-1/2" ports (250 mm x 64 mm)
 Ports include foam sealing kits
- Cable fill:

Estimated cable pass through at port with foam sealing kit installed:

Port Size	Cables (.250" OD)
7" x 2"	32
10" x 2-1/2"	58
- Equipment support:
 - Removable equipment mounting brackets
 - 19"W, EIA-310-D compliant
 - Universal hole spacing, 5/8"-5/8"-1/2" vertical hole spacing
 - Threaded #12-24 equipment mounting holes
 - 4U or 6U, vertical, fixed at center or 4" (100 mm) offset from center
 - Order #12-24 equipment mounting screws separately
- Cable management:
 - Four cable tie points in the enclosure
- Load capacity:
 - 85 lbs (38.6 kg) of equipment total
- Certifications:
 - EIA-310-D compliant
 - UL Listed, UL 2043
- Material:
 - .060" thick (1.52 mm) aluminum sheet
- Construction:
 - Riveted
- Finish:
 - Mill finish, all components

DIMENSIONS

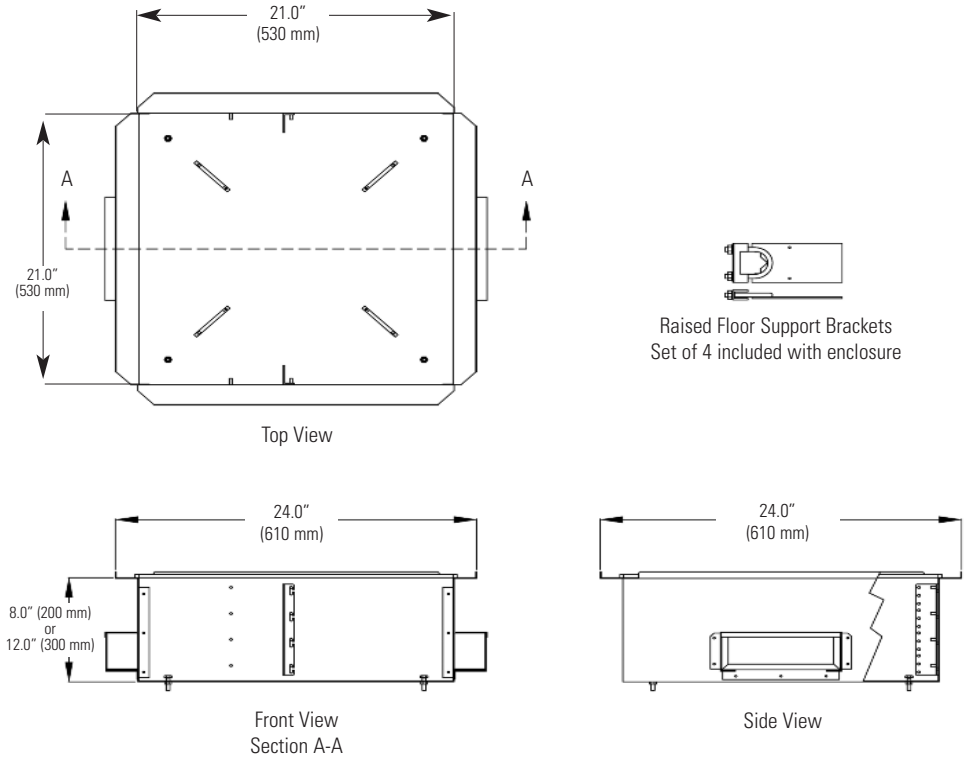

ORDERING INFORMATION

2' x 2' Floor Enclosure		
Part Number	Description	Shipping Weight
A0822-RF-F	4U Fiber Enclosure for 9"D (230 mm) Floor	30 lb (13.6 kg)
A1422-RF-F	6U Fiber Enclosure for 14"D (356 mm) Floor	30 lb (13.6 kg)

Saf-T-Grip® Cable Management Straps		
Part Number	Description	Shipping Weight
02006-201	6"L for 2" Diameter Bundles, Pack of 25	1 lb (0.5 kg)
Equipment Mounting Screws		
40605-001	#12-24 Screws, Zinc, Pack of 50	1 lb (0.5 kg)

