

ETF-450 Control Module Installation Addendum

PRIOR TO INSTALLATION



Multiple Faucets

Multiple faucets can be powered by a single transformer that has been properly sized. Allow a minimum of 15 VA of current rating for each solenoid valve used. Refer to the following example to determine the required current rating for 3 OPTIMA faucets.

Example:

Total number of OPTIMA faucets:	3
Total number of solenoid valves:	3
Multiply by current rating:	15 VA

Minimum current rating of required transformer: 45 VA

Standard Plug-In	ETF-233	120 VAC	35 VA
Standard Box Mount	EL-248-40	120 VAC	40 VA

Optional Transformers Available from Sloan

Box Mount	EL-154	120 VAC	50 VA
Foot Mount	EL-208	120 VAC	100 VA
Box Mount	EL-342	240 VAC	50 VA

All Sloan transformers are 50/60 Hz. Other transformers (not supplied by Sloan) may be used provided they meet UL requirements for Class 2 transformers.

SLOAN® LIMITED WARRANTY SUMMARY

Sloan Valve Company ("Sloan"), warrants its products against defects in materials and workmanship, excluding damage caused by matters beyond Sloan's reasonable control. Instructions for filing claims can be found in the Limited Warranty which can be obtained at www.sloan.com or by requesting a free copy by telephone at 888.756.2614. Sloan will repair or replace your defective product, or provide a refund, as your exclusive remedy. This is only a general summary of Sloan's Limited Warranty so it is important to note that the specific terms, conditions, limitations and exclusions, including the duration of warranty coverage for your particular Sloan product, are contained in the actual Sloan Limited Warranty. The Limited Warranty is subject to applicable laws in your country, state, province or other jurisdiction—and disputes arising under the Limited Warranty are to be resolved by binding arbitration unless you provide Sloan with an opt-out notice no later than 30 days after your purchase date. In case of a conflict with this summary, the terms and conditions set forth in the complete Limited Warranty will prevail.

INSTALL TRANSFORMER

- A** Strip ends of transformer power cable approx. 3/16 to 1/4 inch (5 to 6 mm).
- B** Install strain relief 3 inches (76 mm) from one end of power cable.
- C** Insert power cable and strain relief into hole at back of control module. Install right angle strain relief so that power cable enters the control module from the bottom.

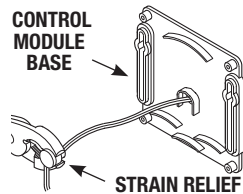

PLUG-IN TRANSFORMERS

Important: DO NOT plug Transformer into receptacle until all wiring has been completed. The Transformer is supplied with a 10 foot Cable; however, this Cable can and should be shortened to meet installation requirements.

MOUNT CONTROL MODULE TO WALL

- A** Install the Control Module in an appropriate location as shown in Rough-in. Control Module must be installed so that all cables enter from the bottom of the unit. When installed, Cables from the Spout and Solenoid Valve to the Control Module should have some slack.
- B** Mount Control Module to wall using Mounting Screws and Plastic Anchors.

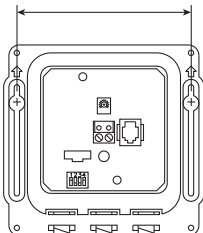

CONTROL MODULE CONNECTIONS

- A** Route Cables from Solenoid Valve and Spout to the Control Module.
- B** Insert Solenoid Valve Connector into the Modular Receptacle on Connector Board
- C** Insert Locking Connector from Faucet Spout into mating Receptacle on Connector Board. Allow 3 to 4 inches (76 to 102 mm) of Cable to extend into the Control Module.
- D** Insert each Conduit Cable into a strain relief slot in the Control Module.

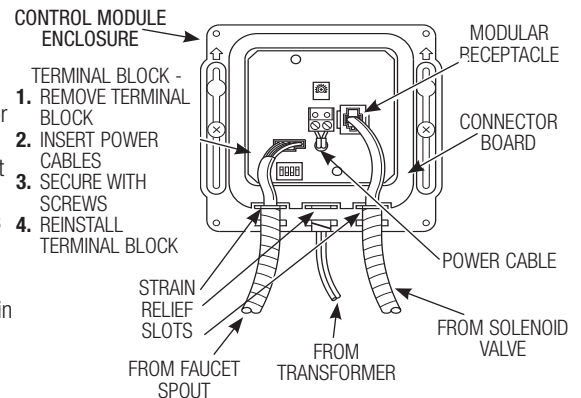

ETF-450 Control Module Installation Addendum

PLUG-IN TRANSFORMER

- A** Plug Transformer into 120 VAC Receptacle.

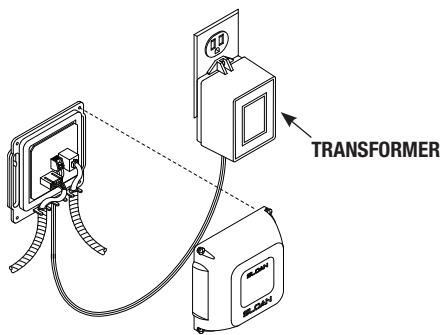

START_UP

- A** Supply power to Transformer.
- B** Open Supply Stop(s). Activate Faucet for 30 seconds by placing hands in front of Sensor. The Solenoid Valve should “click” and water should flow from the Spout. If this does not occur, refer to the Troubleshooting section of this installation instructions.

Note: The Control Module is equipped with two LED lights. When power is supplied by the Transformer, one LED will illuminate green. When Sensor is activated, this LED will change to red. A second red LED illuminates when Solenoid Valve is activated.

RANGE ADJUSTMENT

If range adjustment is required, refer to the following range adjustment procedures.

TO MAKE A RANGE ADJUSTMENT

The Range Potentiometer and Dip Switches are located in Control Module.

Important: Range Potentiometer adjustment screw rotates only 3/4 of a turn. DO NOT over-rotate.

Make certain that Dip Switch number 4 is in the UP position. Using the small screwdriver provided, adjust Range Potentiometer clockwise until green (power ON) indicator LED turns red (Faucet is now picking up sink). Adjust Range Potentiometer back counterclockwise until red LED returns to green. Range is now at maximum.

Cycle Faucet several times to assure that range as adjusted will not inadvertently pick up IR reflection in lavatory. If IR reflection occurs (green LED will flicker red), adjust Range Potentiometer counterclockwise very slightly and again cycle Faucet.

Repeat range adjustment counterclockwise until length of range is at bowl rim of lavatory (plus or minus 1 inch (25 mm)).

Time Out Adjustment

The Faucet Time Out Setting determines the maximum time the Faucet will run upon continuous activation. This timing can be changed to meet individual application requirements.

Refer to Table 1 or label on cover of Control Module along with the following instructions to set the desired Time Out. The Dip Switches used to set the Time Out are located in the Control Module.

Set the Time Out by configuring the number 1, 2 and 3 Dip Switches as shown in Table 1.

Time Out	Dip Switch Setting		
	Switch #1	Switch #2	Switch #3
3 SECONDS	UP	UP	DOWN
6 SECONDS	DOWN	DOWN	UP
12 SECONDS	UP	DOWN	UP
30 SECONDS	UP	DOWN	DOWN
45 SECONDS	UP	UP	UP
1 MINUTE	DOWN	UP	UP
3 MINUTES	DOWN	DOWN	DOWN
20 MINUTES	DOWN	UP	DOWN

Table 1 — Time Out Settings

Unless otherwise specified, all ETF-450 modules leave the factory set with a 30 second Time Out.

Note: The position of Dip Switch #4 (range enhancer setting) does not affect Faucet Time Outs.

Push Cables into slots at the bottom of the Control Module.

Install Control Module Cover using Screws provided.

TEST FAUCET OPERATION

- 1.** A continuous invisible beam of infrared light is emitted from the OPTIMA® Sensor located on the throat of the lavatory faucet.

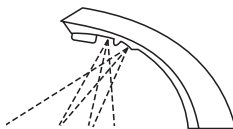

- 2.** As the user's hands enter the beam's effective range (beneath the spray head), the beam is reflected back into the sensor receiver and activates the solenoid valve allowing tempered water to flow from the faucet into the sink. Water will flow until the hands are removed or until the faucet reaches its automatic time out limit setting.



- 3.** When hands are moved away from the OPTIMA® Sensor, the loss of reflected light initiates an electrical signal that deactivates the Solenoid Valve, shutting off the water flow. The Circuit then automatically resets and is ready for the next user.

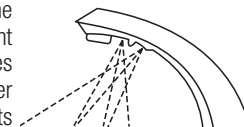

ETF-450 Control Module Installation Addendum

TROUBLESHOOTING GUIDE

Note: Remove Cover from Control Module to check diagnostic lights.

1. PROBLEM: No water is delivered when Faucet is activated.

INDICATOR: If no LED lights illuminate:

CAUSE: No electricity is being supplied to Faucet.

SOLUTION: Ensure that the main power is turned "ON." Check all Transformer, Sensor, Solenoid and Cable Connections. Make sure that Transformer is supplying 24 VAC (Volts AC). If no voltage is detected, replace Transformer.

CAUSE: There is an electrical system malfunction.

SOLUTION: Reset electrical system. Unplug Sensor Connection. Disconnect power to circuit for ten (10) seconds. Reconnect.

INDICATOR: If the GREEN LED does NOT illuminate when power is reconnected:

CAUSE: There is an electrical system malfunction.

SOLUTION: Reset electrical system. Unplug Sensor Connection. Disconnect power to circuit for ten (10) seconds. Reconnect.

CAUSE: The Control Module circuit is "dead."

SOLUTION: Replace ETF-450-A Control Module.

INDICATOR: If GREEN LED illuminates AND changes to RED when hands are in the Sensor's detection zone AND the RED Solenoid LED illuminates:

CAUSE: Water supply stop(s) may be partially closed.

SOLUTION: Open supply stop(s) completely.

CAUSE: Debris is clogging Solenoid Filter.

SOLUTION: Shut off water supply. Remove, clean and reinstall Solenoid Filter.

INDICATOR: If GREEN LED illuminates AND changes to RED when hands are placed in the Sensor's detection zone AND the RED Solenoid LED flickers with a vibrating/clicking noise heard inside the module:

CAUSE: There is a direct short in the Solenoid or Solenoid Cable.

SOLUTION: Replace with ETF-370-A Solenoid.

INDICATOR: If GREEN/RED LED illuminates AND changes to RED when hands are NOT located in the Sensor's detection zone BUT the RED Solenoid LED (in upper left corner of circuit) does NOT illuminate:

CAUSE: Sensor range is set too long and is detecting the sink.

SOLUTION: Reduce Sensor detection range.

CAUSE: Sensor is faulty.

SOLUTION: Replace Sensor.

INDICATOR: If GREEN LED illuminates BUT does NOT change to RED when hands are placed in the Sensor's detection zone:

CAUSE: Sensor range is set too short.

SOLUTION: Increase Sensor detection range.

CAUSE: Sensor is faulty.

SOLUTION: Replace Sensor.

2. PROBLEM: Sensing Range is too short.

CAUSE: Extended Range Sensitivity is required.

SOLUTION: Dip Switch number 4 should be in the "DOWN" (Extended Range Sensitivity) position. Increase range by adjusting Range Potentiometer clockwise (yellow phillips screw in blue base).

3. PROBLEM: Faucet activates by itself (false triggers).

CAUSE: Sensor range is set too long.

SOLUTION: Decrease range by adjusting Range Potentiometer counterclockwise. If necessary, flip Dip Switch number 4 to the "UP" (Reduced Range Sensitivity) position. Check surroundings for factors that contribute to Sensor range detection problems (bright lights, highly reflective surfaces, sunlight, etc.).

4. PROBLEM: Faucet delivers very low flow or just a dribble.

CAUSE: Water supply stop(s) may be partially closed.

SOLUTION: Open supply stop(s) completely.

CAUSE: Debris is clogging Solenoid Filter.

SOLUTION: Shut off water. Remove, clean, and reinstall Solenoid Filter or replace Solenoid Filter ETF-1009-A.

CAUSE: Solenoid is worn or faulty.

SOLUTION: Rebuild with ETF-1009-A Solenoid Repair Kit or replace ETF-370-A Solenoid.

CAUSE: Debris is clogging Faucet Aerator or Spray Head.

SOLUTION: Shut off water. Remove Aerator or Spray Head (use Key if required). Clean and reinstall Aerator or Spray Head.

5. PROBLEM: Faucet does not stop delivering water or continues to drip after user is no longer detected (even after power to the Module has been disconnected).

CAUSE: Solenoid Valve is installed backward.

SOLUTION: Disconnect Solenoid. Reconnect Solenoid with water flow toward the Faucet (see arrow on Solenoid).

CAUSE: Debris is clogging Solenoid.

SOLUTION: Remove and clean Solenoid Operator. If necessary, rebuild with ETF-1009-A Repair Kit.

CAUSE: Seat in Solenoid Valve body is damaged or pitted.

SOLUTION: Replace with ETF-370-A Solenoid.

When assistance is required, please contact Sloan Valve Company Installation Engineering Department at:

1-888-SLOAN-14 (1-888-756-2614) OR 1-847-233-2016

PARTS LIST

1	ETF-370-A	Solenoid Valve, 24 VAC, Includes Wire Harness
2	ETF-450-A	Control Module Assembly
3	ETF-233	Plug-In Transformer
4	EL-248-40	Box Mount Transformer
5	ETF-458-A	Power Cable (Transformer to Control Module) with Strain Relief and two (2) Crimp Connectors

FAUCET CABLE EXTENSION CORDS

Faucet to Control Module

ETF-1005-26	26 Inch (0.7 meter) Length
ETF-1005-36	36 Inch (0.9 meter) Length
ETF-1005-72	72 Inch (1.8 meter) Length
ETF-1005-108	108 Inch (2.7 meter) Length

Solenoid to Control Module

ETF-1003-36	36 Inch (0.9 meter) Length
ETF-1003-48	48 Inch (1.2 meter) Length
ETF-1003-72	72 Inch (1.8 meter) Length
ETF-1003-108	108 Inch (2.7 meter) Length

SOLENOID VALVE REPAIR KITS

ETF-1009-A	Solenoid repair kit
ETF-437-A	Solenoid compression fitting kit

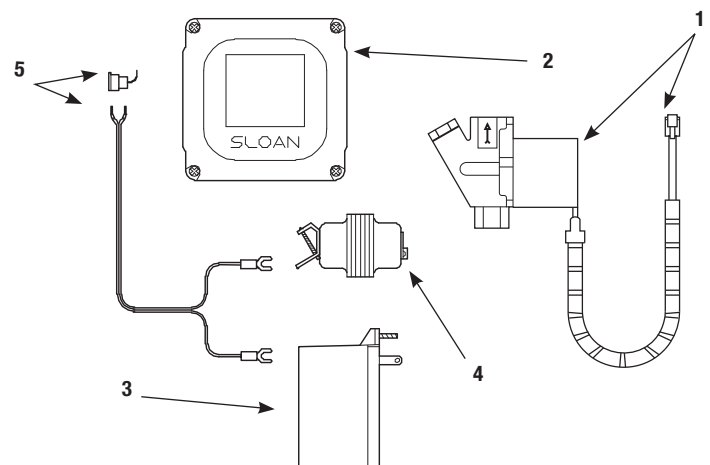

SLOAN • 10500 SEYMOUR AVENUE • FRANKLIN PARK, IL 60131

Phone: 1-800-982-5839 or 1-847-671-4300 • Fax: 1-800-447-8329 or 1-847-671-4380 • www.sloan.com