

## Suction cup B8 Silicone

Article number: 3150287S



- Lifting movement to separate small and thin objects.
- Only lightweight objects should be handled when the lifting force is parallel to the surface.
- Suitable for level adjustment.
- Suction cups of conductive silicone and semi-conductive EPDM are suitable for objects with sensitivity to static electricity.

### Technical data

Description	Unit	Value
Suction cup shape	-	Bellows
Application	-	Dry sheet metal, Electronic / semiconductor, Plastic injection molded parts
Suction cup design	-	Round
Characteristics	-	Dry sheet metal, Electronic / semiconductor, Plastic injection molded parts
Material	-	Silicone (SIL)
Weight, min.	g	0.3
Suction cup model	-	B
Volume	cm <sup>3</sup>	0.15
Height	mm	11.9
Outer diameter, min.	mm	8.8
Outer diameter, actuated	mm	9.6
Fitting size	-	None
Fitting option	-	None
Fitting style	-	None
Fitting type	-	None
Suction cup model	-	B8
Movement, vertical max.	mm	3.5
Curve radius, min.	mm	1.9

### Performance - Lifting forces

B8	Vertical (N)	Parallel (N)
20 -kPa	0.8	
60 -kPa	1.6	
90 -kPa	2.5	

Material	
Name	Silicone, SIL 50° Shore A
Colour	Red
Temperature, min.   °C	-40
Temperature max.   °C	200
Hardness   °Shore A	50

### Material resistance

Alcohol	Good
Concentrated acids	Poor
Ethanol	n/a
Hydrolysis	Fair
Methanol	n/a
Oil	Poor
Oxidation	Excellent
Petrol	Poor
Wear resistance	Good
Weather and ozone	Excellent

### Dimensional drawings

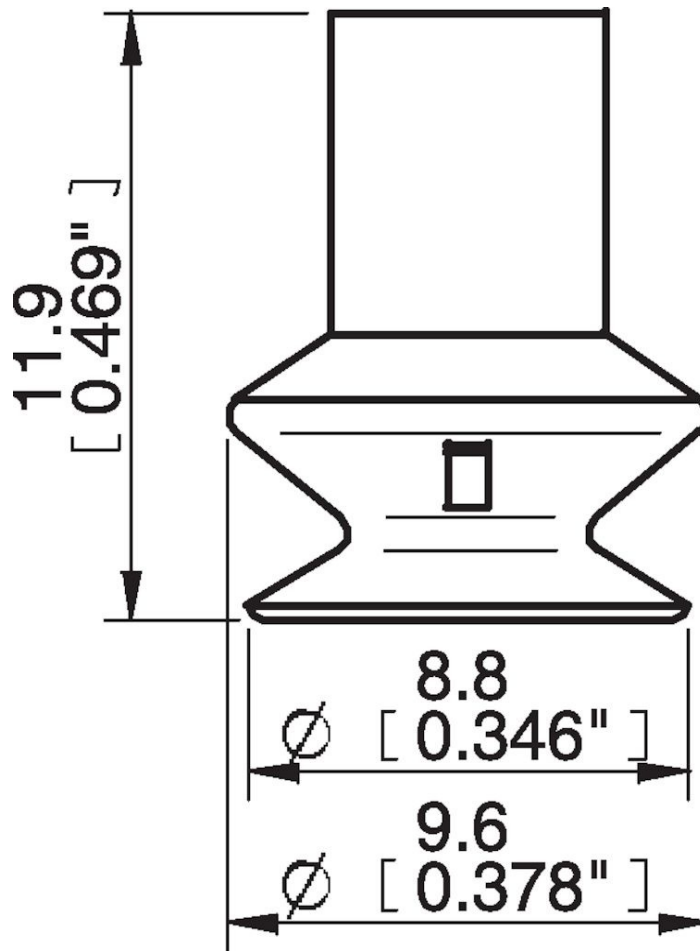

### Values specified in this data sheet are tested at (unless otherwise stated):

- Room temperature (20°C [68°F] ± 3°C [5.5°F]).
- Standard atmosphere (101.3 [29.9 inHg] ± 1.0 kPa [0.3 inHg]).
- Relative humidity 20-70%.
- Compressed air quality, DIN ISO 8573-1 class 4.

### Accessories

3107031 | Fitting M5 male, 5–8