

piINLINE® vacuum generator MINI Si, 8-8 mm

Article number: 0122896



- Patented COAX® cartridge technology.
- High vacuum flow capacity in relation to energy consumption.
- Low weight inline design with push-in fittings for vacuum and compressed air.
- Quick and easy installation directly on the hose.
- Si cartridge for extra vacuum flow.
- Pi cartridge for high performance at low feed pressures.
- Xi cartridge when high flow and deep vacuum is needed.

Technical data

Description	Unit	Value
Material	-	CuZn, Nitrile (NBR), PA, SS
Temperature, max.	°C	80
Temperature, min.	°C	-10
Weight, min.	g	21.8
Feed pressure, max.	MPa	0.7
Noise level, max.	dBA	84
Noise level, min.	dBA	68
Air consumption	NI/s	25.7 l/m (.9 scfm)
Diameter	mm	19
Diameter	mm	8
Diameter	mm	8
Length (A)	mm	96

Performance

Feed pressure MPa	Air consumption NI/s	Vacuum flow (NI/s) at different vacuum levels (-kPa)														Max vacuum kPa
		0	10	20	30	40	50	60	70	75	80	90	95	99		
0.6	0.44	0.69	0.55	0.42	0.28	0.23	0.16	0.12	0.08	0	0	0	0	0	0	≥75

Feed pressure MPa	Air consumption NI/s	Evacuation time (s/l) to reach different vacuum levels (-kPa)														Max vacuum kPa
		10	20	30	40	50	60	70	80	90	95	99	99.5	100.3		
0.6	0.44	0.16	0.37	0.66	1.1	1.4	2.1	3.1	0	0	0	0	0	0	0	≥75

Dimensional drawings

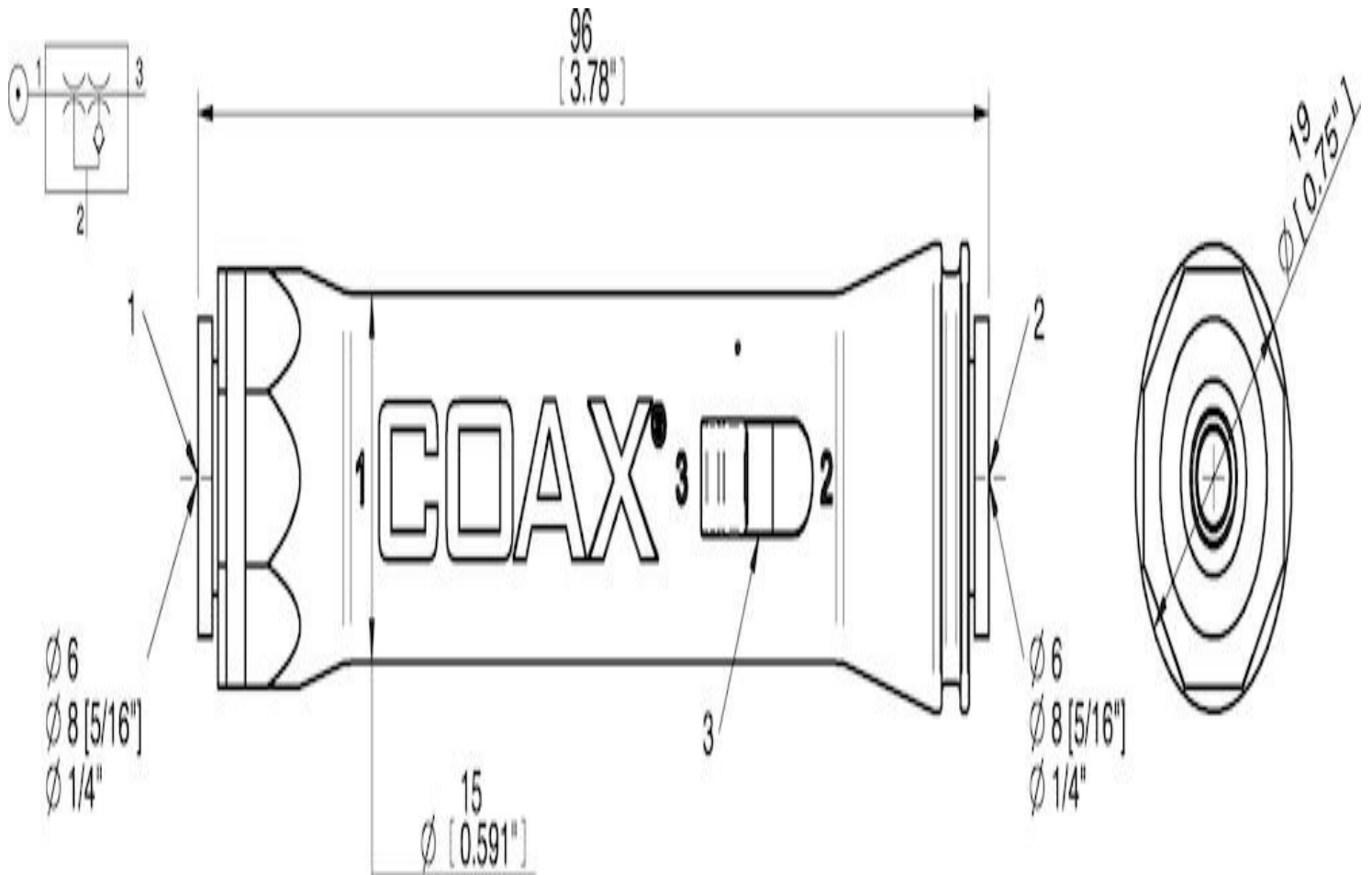

Values specified in this datasheet are tested at (unless otherwise stated):

- Room temperature (20°C [68°F] ± 3°C [5.5°F]).
- Standard atmosphere (101.3 [29.9 inHg] ± 1.0 kPa [0.3 inHg]).
- Compressed air quality, DIN ISO 8573-1 class 4.

Tolerance and accuracy:

- Feed pressure tolerance ±0.02 MPa [2.9 psi]
- Vacuum flow/evacuation time accuracy ±10%.

Accessories

- 0123094 | Snap-in piINLINE® 4x MINI mounting bracket
- 0125466 | Silencer piINLINE® MINI
- 0126009 | Snap-in piINLINE® 1x MINI mounting bracket for silencer