

Suction cup U30 Silicone FCM

Article number: 0200441

- The silicone material complies with FDA 21 CFR 177.2600 & EU 1935/2004.
- Suitable for objects with flat or slightly curved surfaces.
- Also used for concave objects.



Technical data

Description	Unit	Value
Suction cup shape	-	Universal
Application	-	Food contact materials (FDA & EU), non-detectable
Suction cup design	-	Round
Characteristics	-	Food contact materials (FDA & EU), non-detectable
Material	-	Silicone (SIL)
Weight, min.	g	1.8
Suction cup model	-	U
Volume	cm ³	2
Height	mm	9.5
Outer diameter, min.	mm	32
Fitting size	-	None
Fitting option	-	None
Fitting style	-	None
Fitting type	-	None
Suction cup model	-	U30
Movement, vertical max.	mm	3.5
Curve radius, min.	mm	20

Performance - Lifting forces

U30	Vertical (N)	Parallel (N)
20 -kPa	12	7.8
60 -kPa	25	9.8
90 -kPa	30	11

Material	
Name	Silicone (SIL FDA) 50° Shore
Colour	Transparent
Temperature, min. °C	-40
Temperature max. °C	200
Hardness °Shore A	50

Material resistance

Alcohol	Good
Concentrated acids	Poor
Ethanol	n/a
Hydrolysis	Fair
Methanol	n/a
Oil	Poor
Oxidation	Excellent
Petrol	Poor
Wear resistance	Good
Weather and ozone	Excellent

Dimensional drawings

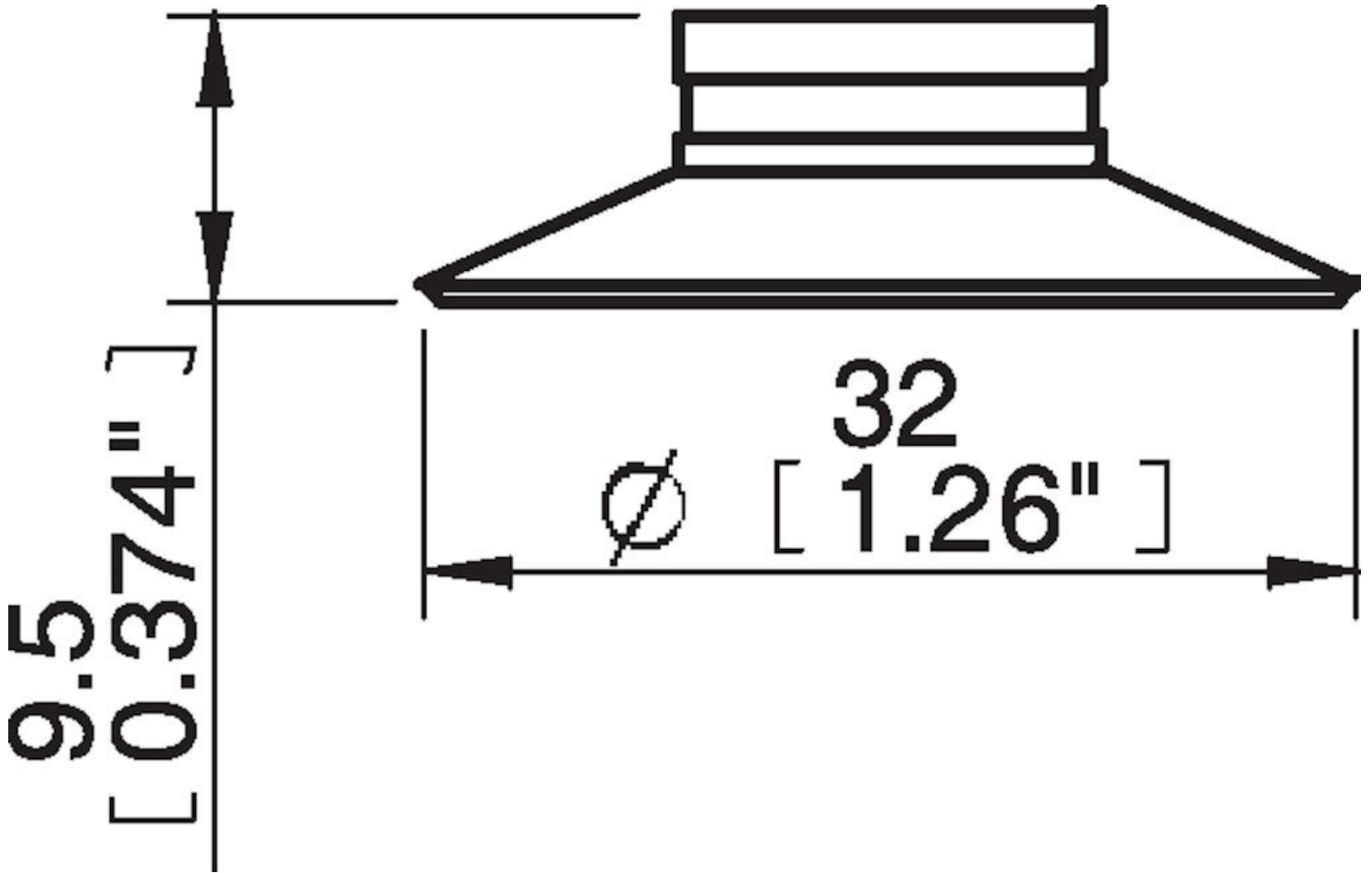

Values specified in this data sheet are tested at (unless otherwise stated):

- Room temperature (20°C [68°F] ± 3°C [5.5°F]).
- Standard atmosphere (101.3 [29.9 inHg] ± 1.0 kPa [0.3 inHg]).
- Relative humidity 20-70%.
- Compressed air quality, DIN ISO 8573-1 class 4.

Accessories

0101152 | Fitting G1/8" male/M5 female, with mesh filter

3250085 | Fitting G1/8" male, with mesh filter

3250088 | Fitting 1/8" NPT male, with mesh filter