

## Suction cup F110 Silicone

Article number: 3150132S

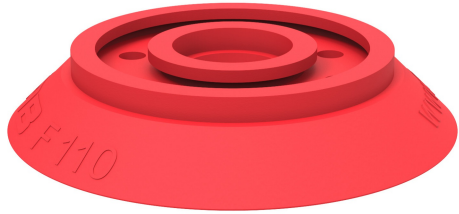

- Suitable for flat objects.
- Good stability and little inherent movement.
- Recommended when the lifting force is parallel to the surface of the object.
- Cleats prevent thin, sensitive objects from being deformed and gives extra friction when the lifting force is parallel.

### Technical data

Description	Unit	Value
Suction cup shape	-	Flat
Application	-	Dry sheet metal
Suction cup design	-	Round
Characteristics	-	Dry sheet metal
Material	-	Silicone (SIL)
Weight, min.	g	66
Suction cup model	-	F
Volume	cm <sup>3</sup>	70
Height	mm	20
Outer diameter, min.	mm	112
Outer diameter, actuated	mm	115.3
Fitting size	-	None
Fitting option	-	None
Fitting style	-	None
Fitting type	-	None
Suction cup model	-	F110
Movement, vertical max.	mm	4
Curve radius, min.	mm	250

### Performance - Lifting forces

F110	Vertical (N)	Parallel (N)
20 -kPa	140	140
60 -kPa	420	250
90 -kPa	560	300

Material	
Name	Silicone, SIL 50° Shore A
Colour	Red
Temperature, min.   °C	-40
Temperature max.   °C	200
Hardness   °Shore A	50

#### Material resistance

Alcohol	Good
Concentrated acids	Poor
Ethanol	n/a
Hydrolysis	Fair
Methanol	n/a
Oil	Poor
Oxidation	Excellent
Petrol	Poor
Wear resistance	Good
Weather and ozone	Excellent

#### Dimensional drawings

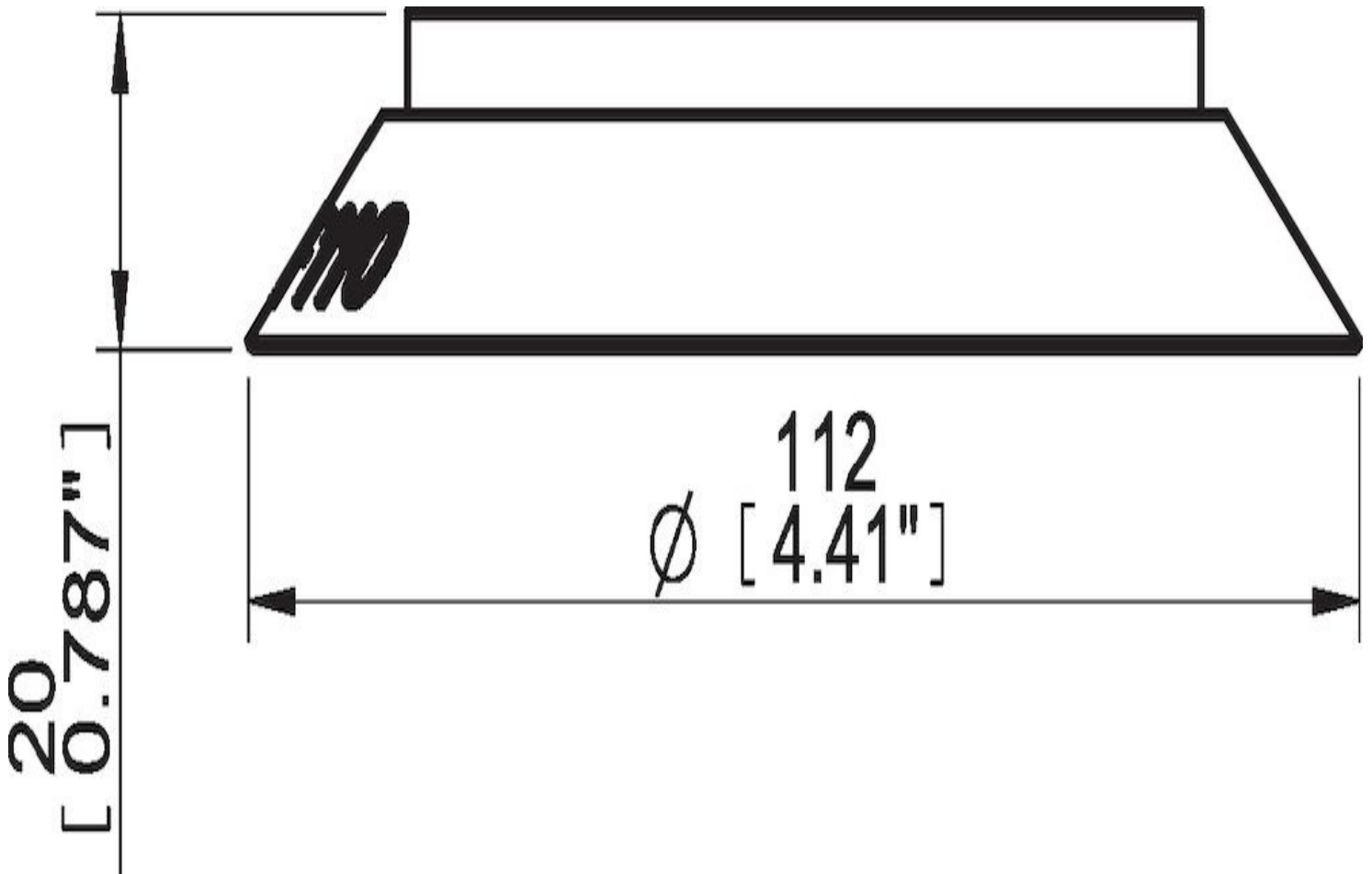

#### Values specified in this data sheet are tested at (unless otherwise stated):

- Room temperature (20°C [68°F] ± 3°C [5.5°F]).
- Standard atmosphere (101.3 [29.9 inHg] ± 1.0 kPa [0.3 inHg]).
- Relative humidity 20-70%.
- Compressed air quality, DIN ISO 8573-1 class 4.

**Accessories**

0100557 | Fitting 110 G3/8" female, with mesh filter

0100559 | Fitting 110, 3/8" NPSF female, with mesh filter

0100561 | Fitting 110, G1/2" female, with mesh filter

0100563 | Fitting 110, G1/2" female, with cone valve

3250007 | Fitting G1/2" female AI, with mesh filter