

Suction cup B110 Silicone

Article number: 3150108S



- Suitable for level adjustment. Several short bellows in one lifting device can handle objects with height differences and varying shapes, for example embossed or corrugated plates.
- The lifting movement can be used to separate small and thin objects.
- Only lightweight objects should be handled when the lifting force is parallel to the surface of the object, in order to achieve good precision and safe lifting movement.

Technical data

Description	Unit	Value
Suction cup shape	-	Bellows
Application	-	Dry sheet metal
Suction cup design	-	Round
Characteristics	-	Dry sheet metal
Material	-	Silicone (SIL)
Weight, min.	g	120
Suction cup model	-	B
Volume	cm ³	310
Height	mm	54.3
Outer diameter, min.	mm	115
Outer diameter, actuated	mm	129
Fitting size	-	None
Fitting option	-	None
Fitting style	-	None
Fitting type	-	None
Suction cup model	-	B110
Movement, vertical max.	mm	34.6
Curve radius, min.	mm	60

Performance - Lifting forces

B110	Vertical (N)	Parallel (N)
20 -kPa	137	
60 -kPa	343	
90 -kPa	461	

Material	
Name	Silicone, SIL 50° Shore A
Colour	Red
Temperature, min. °C	-40
Temperature max. °C	200
Hardness °Shore A	50

Material resistance

Alcohol	Good
Concentrated acids	Poor
Ethanol	n/a
Hydrolysis	Fair
Methanol	n/a
Oil	Poor
Oxidation	Excellent
Petrol	Poor
Wear resistance	Good
Weather and ozone	Excellent

Dimensional drawings

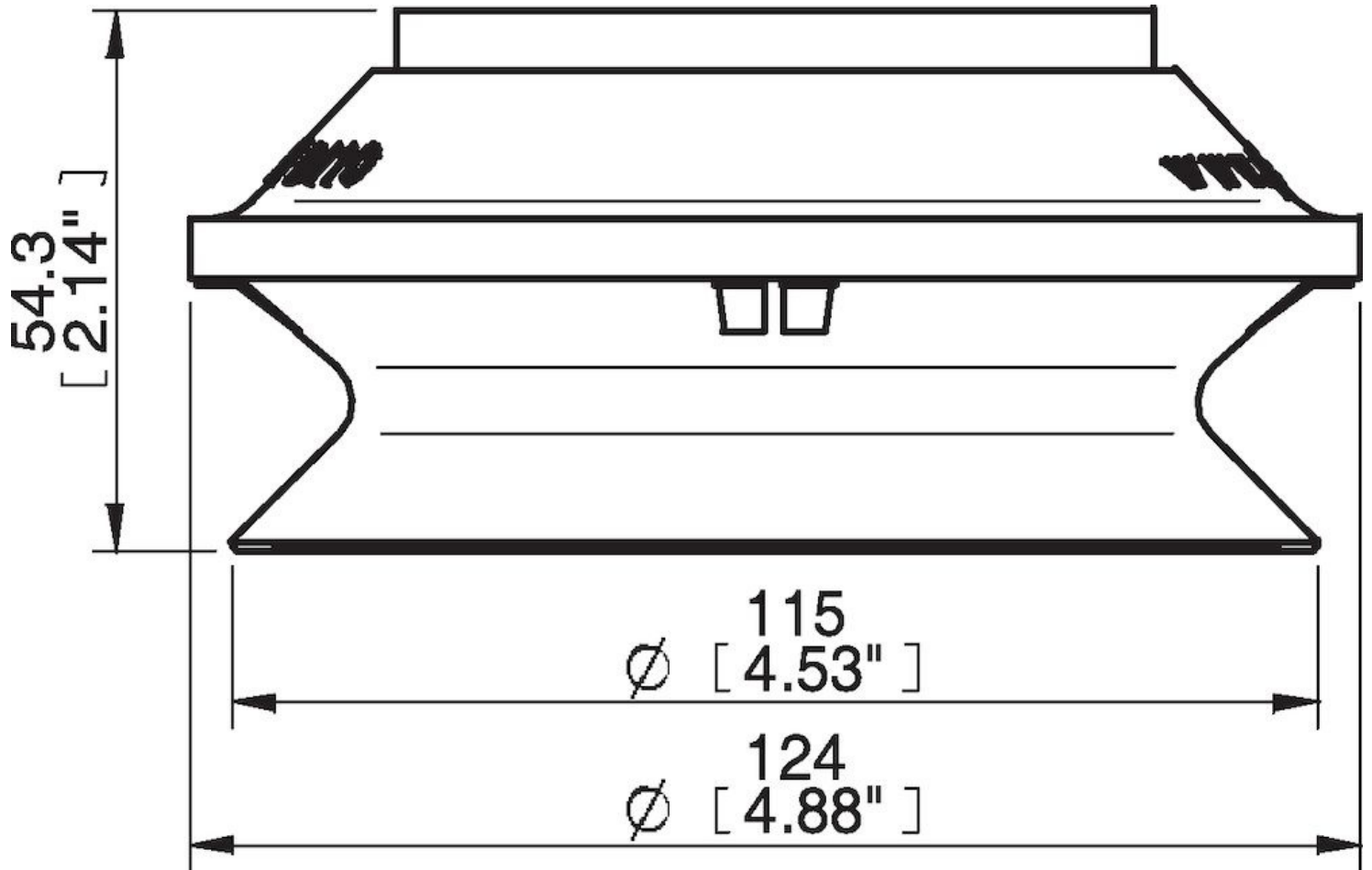

Values specified in this data sheet are tested at (unless otherwise stated):

- Room temperature (20°C [68°F] ± 3°C [5.5°F]).
- Standard atmosphere (101.3 [29.9 inHg] ± 1.0 kPa [0.3 inHg]).
- Relative humidity 20-70%.
- Compressed air quality, DIN ISO 8573-1 class 4.

Accessories

0100557 | Fitting 110 G3/8" female, with mesh filter

0100559 | Fitting 110, 3/8" NPSF female, with mesh filter

0100561 | Fitting 110, G1/2" female, with mesh filter

3250007 | Fitting G1/2" female AI, with mesh filter