

COAX® cartridge MINI Si08-2, extra non-return valve

Article number: 0113587



- Two-stage COAX® cartridge - MINI - with small mounting dimensions.
- Large vacuum flow in relation to energy consumption.
- Good for handling porous materials or if surface leakage is present.

Technical data

Description	Unit	Value
Material	-	Al, Nitrile (NBR), PA, SS
Temperature, max.	°C	80
Temperature, min.	°C	-10
Weight, max.	g	9.9
Weight, min.	g	2.8
Feed pressure, max.	MPa	0.7

Performance

Feed pressure MPa	Air consumption NI/s	Vacuum flow (NI/s) at different vacuum levels (-kPa)													Max vacuum kPa		
		0	10	20	30	40	50	60	70	80	90	95	99				
0.4	0.31	0.71	0.53	0.34	0.26	0.18	0.09	0.01	0	0	0	0	0	0	0	0	≥60
0.5	0.38	0.77	0.61	0.43	0.29	0.23	0.15	0.08	0.01	0	0	0	0	0	0	0	≥70
0.6	0.44	0.77	0.67	0.51	0.33	0.23	0.16	0.12	0.08	0	0	0	0	0	0	0	≥75

Feed pressure MPa	Air consumption NI/s	Evacuation time (s/l) to reach different vacuum levels (-kPa)													Max vacuum kPa		
		10	20	30	40	50	60	70	80	90	95	99	99.5	100.3			
0.4	0.31	0.16	0.39	0.72	1.2	1.9	3.9	0	0	0	0	0	0	0	0	0	≥60
0.5	0.38	0.14	0.34	0.62	1	1.5	2.4	4.6	0	0	0	0	0	0	0	0	≥70
0.6	0.44	0.14	0.31	0.55	0.9	1.4	2.1	3.1	0	0	0	0	0	0	0	0	≥75

Feed pressure MPa	Air consumption NI/s	Blow flow (NI/s) at different pressure levels (-kPa)													Max pressure kPa			
		0	10	20	30	40	50	60	70	80	90	100	110	120		130	140	
0.6	0.44	1.21	1.13	1	0.84	0.78	0.73	0.65	0.53	0	0	0	0	0	0	0	0	≥75

Dimensional drawings

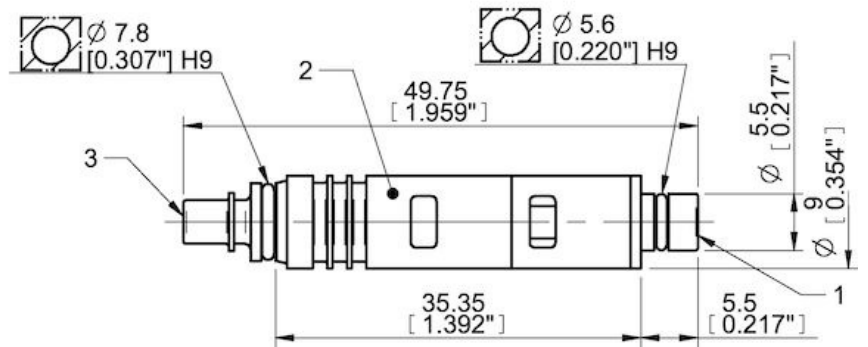
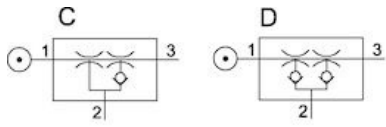

Values specified in this datasheet are tested at (unless otherwise stated):

- Room temperature (20°C [68°F] ± 3°C [5.5°F]).
- Standard atmosphere (101.3 [29.9 inHg] ± 1.0 kPa [0.3 inHg]).
- Compressed air quality, DIN ISO 8573-1 class 4.

Tolerance and accuracy:

- Feed pressure tolerance ±0.02 MPa [2.9 psi]
- Vacuum flow/evacuation time accuracy ±10%.

Accessories

0106344 | Exhaust adapter

0111977 | Silencer COAX® MINI