

## Vacuplus MINI slim Pi12-2

Article number: 0223806

- Small and compact sizes
- Symmetric vacuum interfaces on top and bottom ensures flexible installation
- Patented COAX® technology



### Technical data

Description	Unit	Value
Material	-	Al, Nitrile (NBR), PA
Temperature, max.	°C	50
Temperature, min.	°C	-10
Weight, max.	g	52
Feed pressure, max.	MPa	0.7
Noise level, max.	dBA	74
Noise level, min.	dBA	60

### Performance

Feed pressure MPa	Air consumption NI/s	Vacuum flow (NI/s) at different vacuum levels (-kPa)													Max vacuum kPa
		0	10	20	30	40	50	60	70	75	80	90	95	99	
0.31	0.44	0.68	0.6	0.44	0.27	0.19	0.14	0.1	0.06	0	0.03	0	0	0	≥90

Feed pressure MPa	Air consumption NI/s	Evacuation time (s/l) to reach different vacuum levels (-kPa)													Max vacuum kPa
		10	20	30	40	50	60	70	80	90	95	99	99.5	100.3	
0.31	0.44	0.17	0.32	0.58	1.1	1.8	2.7	4	6.4	0	0	0	0	0	≥90

## Dimensional drawings

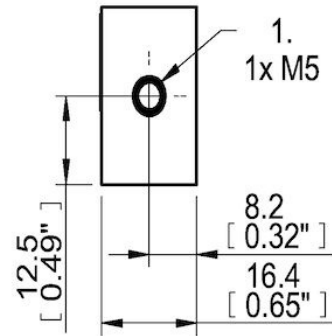
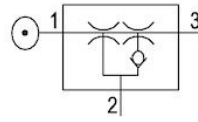
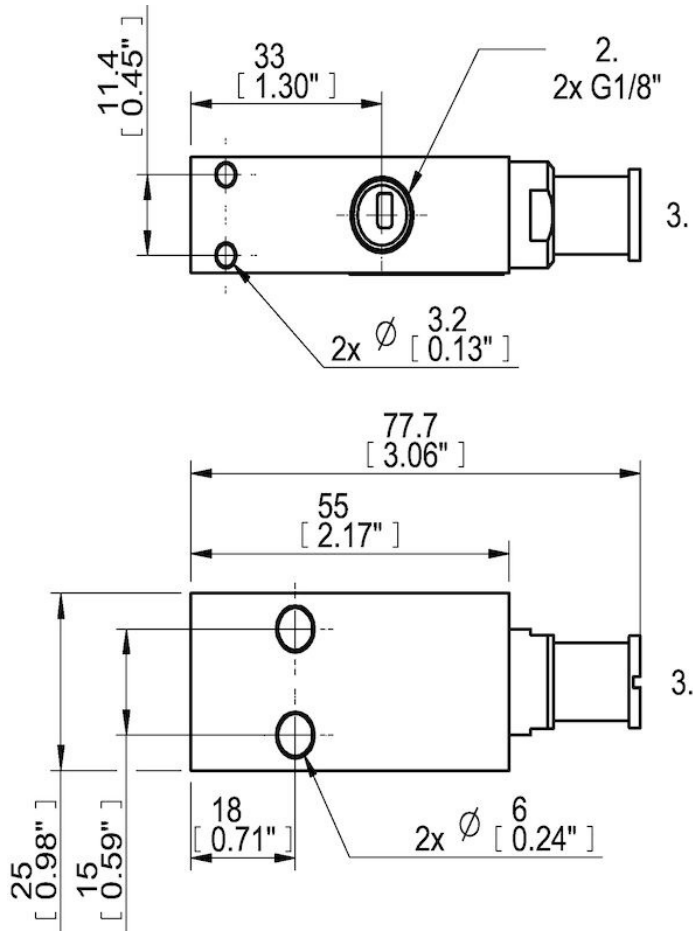

Values specified in this datasheet are tested at (unless otherwise stated):

- Room temperature (20°C [68°F] ± 3°C [5.5°F]).
- Standard atmosphere (101.3 [29.9 inHg] ± 1.0 kPa [0.3 inHg]).
- Compressed air quality, DIN ISO 8573-1 class 4.

Tolerance and accuracy:

- Feed pressure tolerance ±0.02 MPa [2.9 psi]
- Vacuum flow/evacuation time accuracy ±10%.