

## Suction cup B20 Chloroprene

Article number: 0101101



- Suitable for level adjustment. Several short bellows in one lifting device can handle objects with height differences and varying shapes, for example embossed or corrugated plates.
- The lifting movement can be used to separate small and thin objects.
- Only lightweight objects should be handled when the lifting force is parallel to the surface of the object, in order to achieve good precision and safe lifting movement.

### Technical data

Description	Unit	Value
Suction cup shape	-	Bellows
Application	-	Dry sheet metal, Plastic injection molded parts
Suction cup design	-	Round
Characteristics	-	Dry sheet metal, Plastic injection molded parts
Material	-	Chloroprene (CR)
Weight, min.	g	3.2
Suction cup model	-	B
Volume	cm <sup>3</sup>	2.7
Height	mm	19
Outer diameter, min.	mm	22.2
Outer diameter, actuated	mm	26
Fitting size	-	None
Fitting option	-	None
Fitting style	-	None
Fitting type	-	None
Suction cup model	-	B20
Movement, vertical max.	mm	10
Curve radius, min.	mm	10

### Performance - Lifting forces

B20	Vertical (N)	Parallel (N)
20 -kPa	5.9	2.9
60 -kPa	9.8	5.4
90 -kPa	14	8.22

Material	
Name	Chloroprene (CR) 50° Shore A
Colour	Black
Temperature, min.   °C	-40
Temperature max.   °C	110
Hardness   °Shore A	50

#### Material resistance

Alcohol	Good
Concentrated acids	Poor
Ethanol	n/a
Hydrolysis	Good
Methanol	n/a
Oil	Fair
Oxidation	Good
Petrol	Fair
Wear resistance	Excellent
Weather and ozone	Good

#### Dimensional drawings

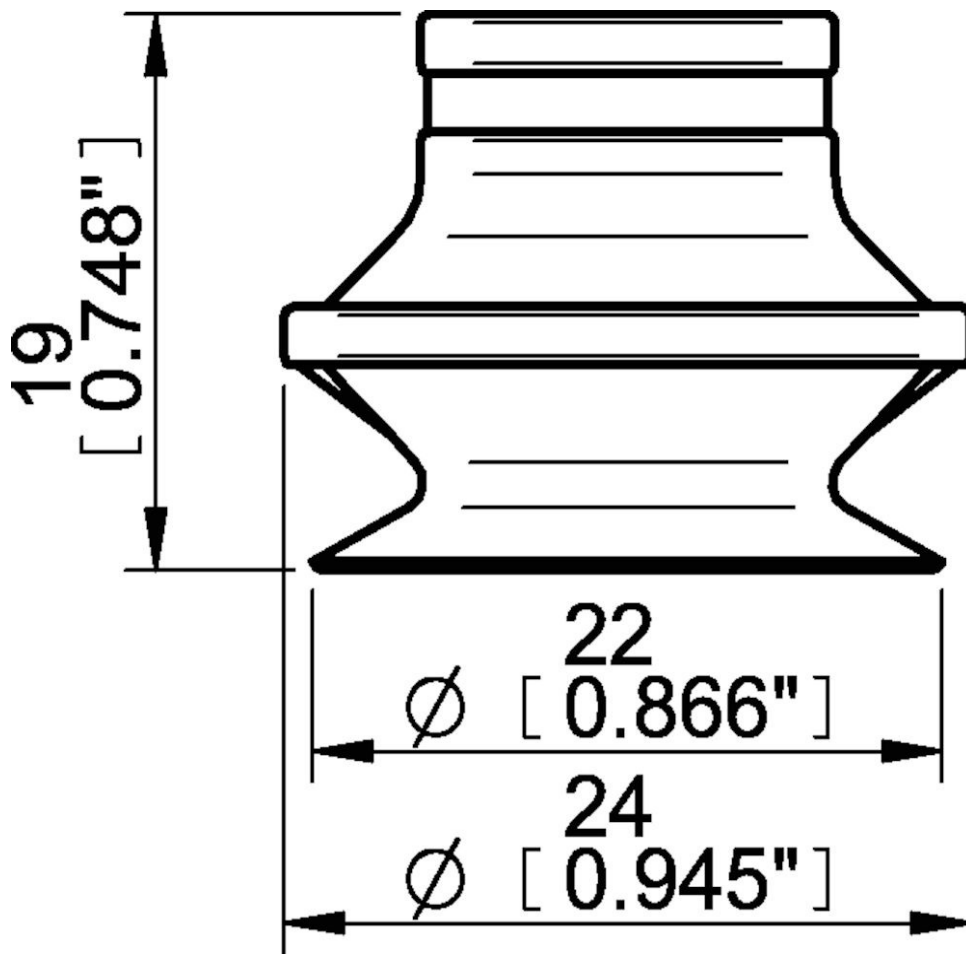

#### Values specified in this data sheet are tested at (unless otherwise stated):

- Room temperature (20°C [68°F] ± 3°C [5.5°F]).
- Standard atmosphere (101.3 [29.9 inHg] ± 1.0 kPa [0.3 inHg]).
- Relative humidity 20-70%.
- Compressed air quality, DIN ISO 8573-1 class 4.