

COAX® in piGRIP® Bi

Article number: 0201096

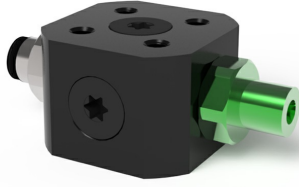

- Fully decentralized vacuum unit based on patented COAX® technology.
- Quickest response time and very high energy efficiency.
- Easy system dimensioning – small risk for mistakes.
- Available with a variation of two-stage COAX® MICRO cartridges.
- Suitable for high vacuum flow.
- Suitable for extra capacity/dirt tolerance.

Technical data

Description	Unit	Value
Material	-	Al, CuZn, Nitrile (NBR), PA
Temperature, max.	°C	80
Temperature, min.	°C	-10
Weight, min.	g	45
Feed pressure, max.	MPa	0.7
Noise level, max.	dBA	61
Noise level, min.	dBA	55

Performance

Feed pressure MPa	Air consumption Nl/s	Vacuum flow (Nl/s) at different vacuum levels (-kPa)													Max vacuum kPa
		0	10	20	30	40	50	60	70	75	80	90	95	99	
0.18	0.14	0.23	0.15	0.06	0.04	0.035	0.023	0.013	0.006	0	0	0	0	0	≥83

Feed pressure MPa	Air consumption Nl/s	Evacuation time (s/l) to reach different vacuum levels (-kPa)													Max vacuum kPa
		10	20	30	40	50	60	70	80	90	95	99	99.5	100.3	
0.18	0.14	0.5	1.4	3.9	6.4	10	16	28	51	0	0	0	0	0	≥83

Dimensional drawings

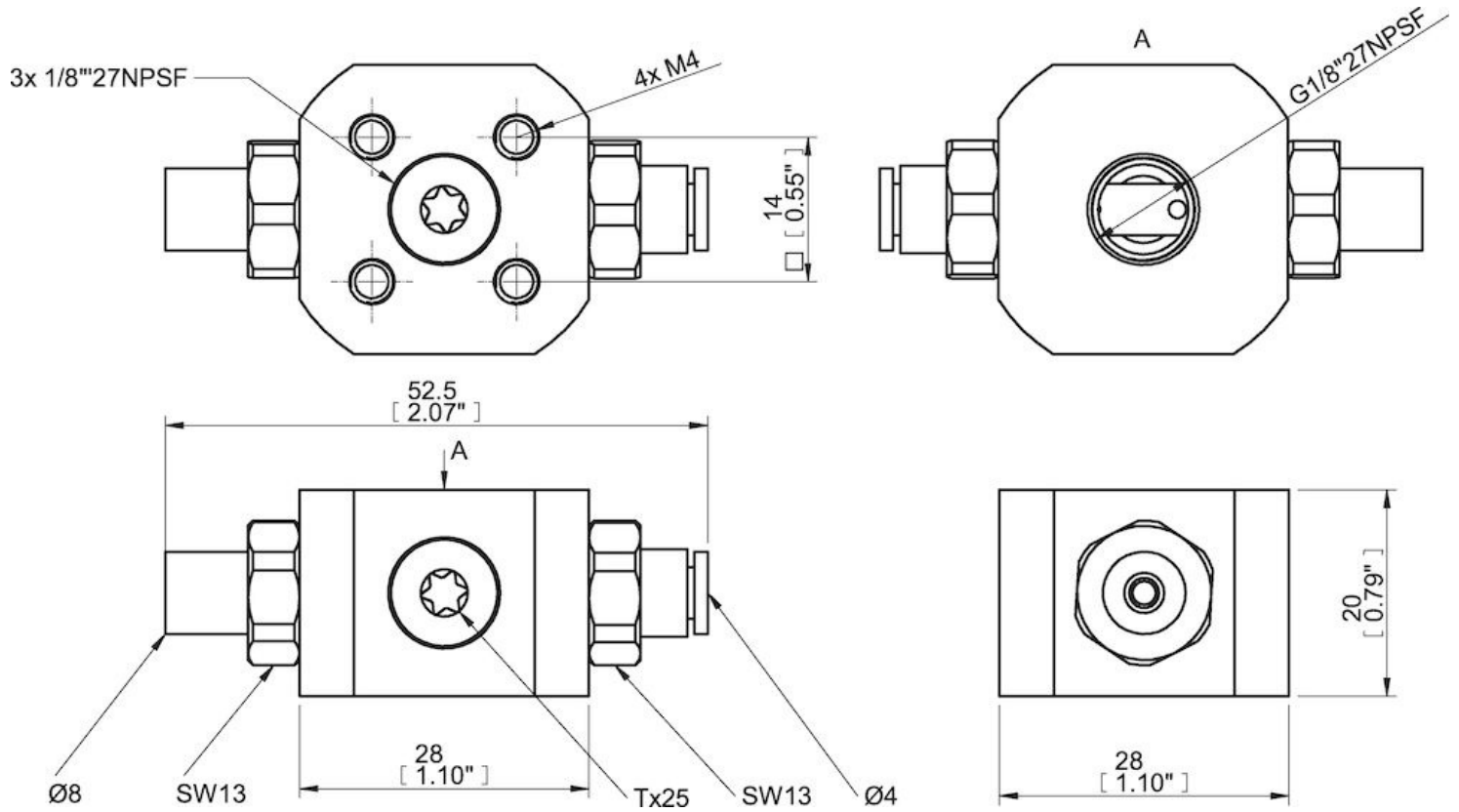

Values specified in this datasheet are tested at (unless otherwise stated):

- Room temperature (20°C [68°F] ± 3°C [5.5°F]).
- Standard atmosphere (101.3 [29.9 inHg] ± 1.0 kPa [0.3 inHg]).
- Compressed air quality, DIN ISO 8573-1 class 4.

Tolerance and accuracy:

- Feed pressure tolerance ±0.02 MPa [2.9 psi]
- Vacuum flow/evacuation time accuracy ±10%.

Accessories

- 0106915 | Mounting kit 4xM4 VGS3010
- 0106927 | Mounting kit M8/16 VGS3010
- 0106949 | Mounting kit M8/27 04 VGS3010
- 0108488 | Mounting kit M6/22 07 top VGS3010