

Suction cup OF55x150P Polyurethane 60

Article number: 0109908

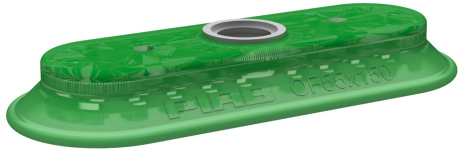

- Suitable for flat and rough surfaces.
- Fair stability and little inherent movement.
- Recommended when the lifting force is parallel to the surface of the object.
- Cleats prevent thin, sensitive objects from being deformed and give extra friction when the lifting force is parallel to the surface of the object.
- DURAFLEX® are suction cups manufactured in a specially developed material that features the elasticity of rubber and wear resistance of polyurethane. The material does not leave any marks on the objects handled.

Technical data

Description	Unit	Value
Suction cup shape	-	Flat
Application	-	Mark Free
Suction cup design	-	Oval
Characteristics	-	Mark free
Material	-	Polyurethane (PU)
Weight, min.	g	109
Suction cup model	-	OF
Volume	cm ³	37
Height	mm	21
Length	mm	154
Outer diameter, min.	mm	154
Fitting size	-	None
Fitting option	-	None
Fitting style	-	None
Fitting type	-	None
Width	mm	59
Suction cup model	-	OF55x150P PU60
Movement, vertical max.	mm	3
Curve radius, min.	mm	150

Performance - Lifting forces

OF55x150P PU60	Vertical (N)	Parallel (N)
20 -kPa	134	128
60 -kPa	376	338
90 -kPa	558	477

Material	
Name	Polyurethane (PU60)
Colour	Green transparent
Temperature, min. °C	10
Temperature max. °C	50
Hardness °Shore A	60

Material resistance

Alcohol	n/a
Concentrated acids	Fair
Ethanol	Fair
Hydrolysis	Fair
Methanol	Poor
Oil	Excellent
Oxidation	Poor
Petrol	Fair
Wear resistance	Excellent
Weather and ozone	Excellent

Dimensional drawings

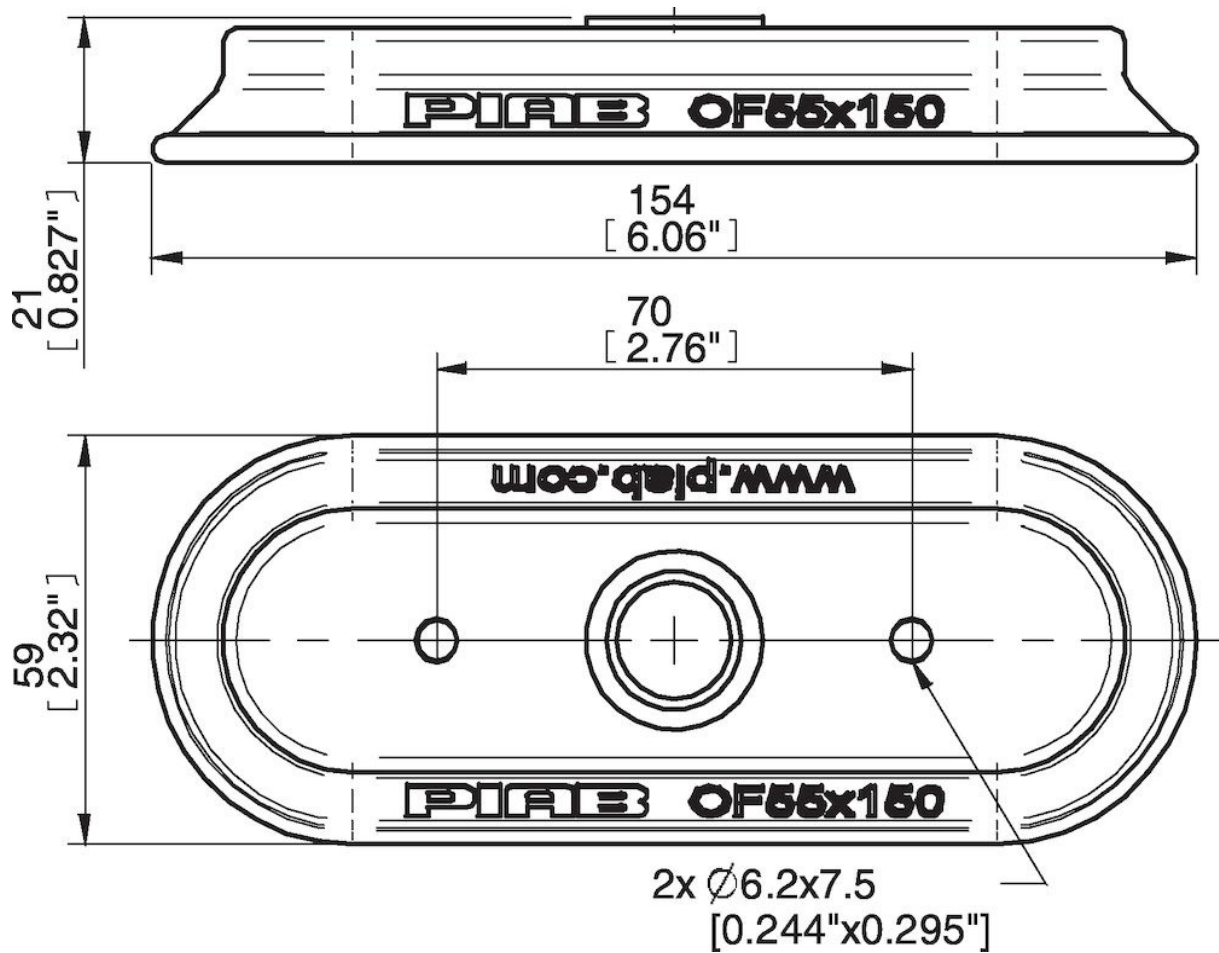

Values specified in this data sheet are tested at (unless otherwise stated):

- Room temperature (20°C [68°F] ± 3°C [5.5°F]).
- Standard atmosphere (101.3 [29.9 inHg] ± 1.0 kPa [0.3 inHg]).
- Relative humidity 20-70%.
- Compressed air quality, DIN ISO 8573-1 class 4.

Accessories

0107148 | Thread insert G3/8" male, with O-ring and mesh filter