

Vactivator V18/20

Article number: 0129516



- Actuated by vacuum only.
- Automatic extension and retraction.
- Self-adjusting stroke, the piston with a suction cup returns home as soon as it seals off the object.
- Suction cup ordered separately.
- Simple solution for high picking speed.
- Easy installation.
- Designed for millions of cycles under normal industrial conditions.

Technical data

Description	Unit	Value
Material	-	Al, CuZn, Iron FE, Nitrile (NBR), POM, SS
Load, vertical, max.	N	4.9
Temperature, max.	°C	40
Temperature, min.	°C	10
Weight, min.	g	90
Flow (Min. vacuum flow)	l/s	0.5
Action range/Stroke	mm	20
Bore through diameter	mm	18
Mounting position	-	Vertical
Vacuum, max.	-kPa	100
Vacuum, min.	-kPa	30

Dimensional drawings

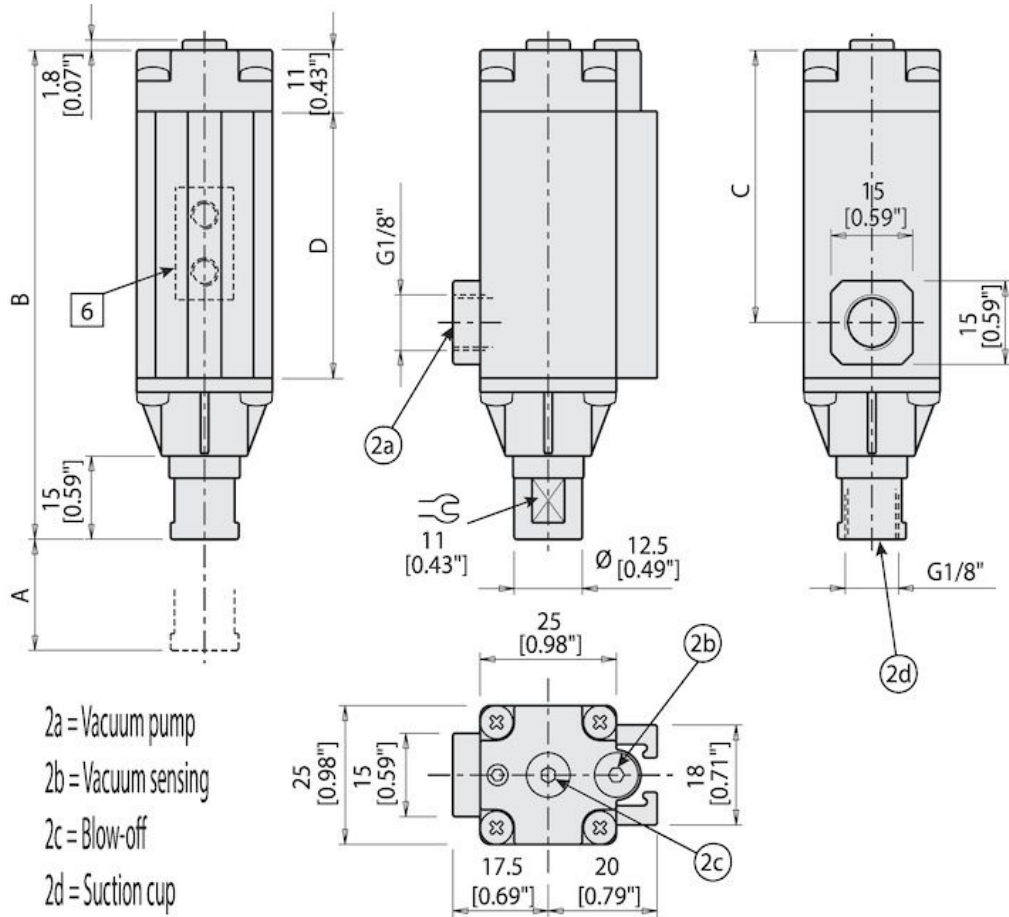

	V18/20	V18/40
A	20 [0.79"]	40 [1.57"]
B	88 [3.46"]	119 [4.69"]
C	49 [1.93"]	80 [3.15"]
D	48 [1.89"]	79 [3.11"]

