

Professional Range Mark 2

Filter+Regulator+Lubricator



Specification:

Type	FM2-21-01-C	FM2-31-02-C	FM2-41-03-C FM2-41-04-C	FM2-51-06-C FM2-51-10-C
Port size G	1/8" · 1/4"	1/4" · 3/8"	3/8" · 1/2"	3/4" · 1"
Gauge thread G	1/8"		1/4"	
Fluid	Air			
Operating pressure range MPa	0.15-0.85			
Max.Flow rate L/min	5000	2000	4000	5000
Ambient temperature °C	-10-60			
Filter precision	Standard: 20 μ m			
Oil recommended	ISO VG32			
Cup material	Polycarbonate			
Structure	Overflow type			
Optional	Guard cup	-	●	●
	Bracket	20T	30T	40T

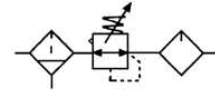

Notes 1: The guard cup of AC201A series can be optional, 2: The cups of AC201A, AC301A series can be optional

Inner structure drawing:

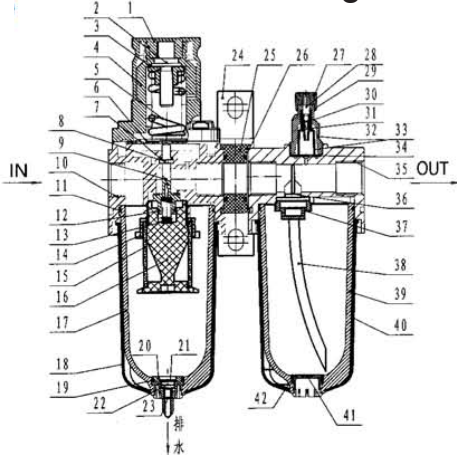

No	code	No	code	No	code
1	knob	15	cartridge	29	O ring
2	nut	16	baffle body	30	middle doom
3	screw	17	water cup	31	O-ring
4	regulator cover	18	guard cup	32	doom outer cover
5	regulator spring	19	O-ring	33	middle doom
6	diaphragm	20	drain doom	34	seals
7	O-ring	21	circlip	35	lubricator body
8	regulator core	22	drain nozzle	36	damping fin
9	regulator corewasher	23	drain spring	37	bolt
10	filter regulator body	24	breaket	38	oil tube
11	O-ring	25	connecting block	39	oil cup
12	O-ring	26	O-ring	40	guard cup
13	regulator core spring	27	doom button	41	oil cup block
14	impeller	28	adjust pin	42	O-ring

Dimension (mm):

FM2-21-01-C

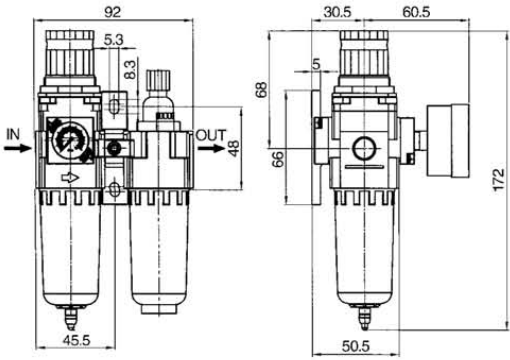

FM2-31-02-C

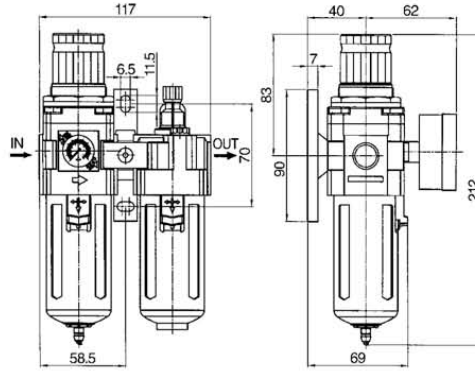

FM2-41-03-C & FM2-41-04-C

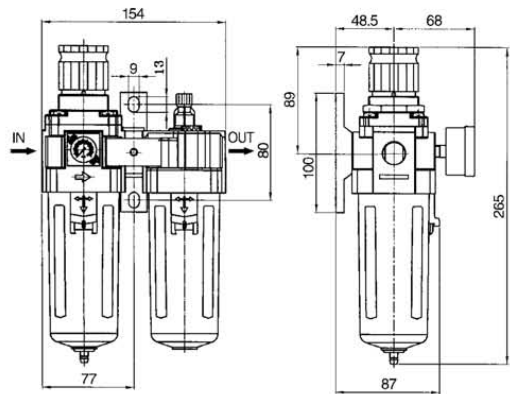

FM2-51-06-C & FM2-51-10-C

