

## Suction cup D15-2 Silicone

Article number: 3150135S

- Suitable for objects with curved or irregular surfaces.
- Grips around corners and edges.



### Technical data

Description	Unit	Value
Suction cup shape	-	Deep
Application	-	Plastic injection molded parts
Suction cup design	-	Round
Characteristics	-	Plastic injection molded parts
Material	-	Silicone (SIL)
Weight, min.	g	1.2
Suction cup model	-	D
Volume	cm <sup>3</sup>	0.9
Height	mm	16.6
Outer diameter, min.	mm	16
Fitting size	-	None
Fitting option	-	None
Fitting style	-	None
Fitting type	-	None
Suction cup model	-	D15-2
Movement, vertical max.	mm	3.2
Curve radius, min.	mm	6

### Performance - Lifting forces

D15-2	Vertical (N)	Parallel (N)
20 -kPa	2.9	2.8
60 -kPa	7.8	6.3
90 -kPa	11	7

Material	
Name	Silicone, SIL 50° Shore A
Colour	Red
Temperature, min.   °C	-40
Temperature max.   °C	200
Hardness   °Shore A	50

### Material resistance

Alcohol	Good
Concentrated acids	Poor
Ethanol	n/a
Hydrolysis	Fair
Methanol	n/a
Oil	Poor
Oxidation	Excellent
Petrol	Poor
Wear resistance	Good
Weather and ozone	Excellent

### Dimensional drawings

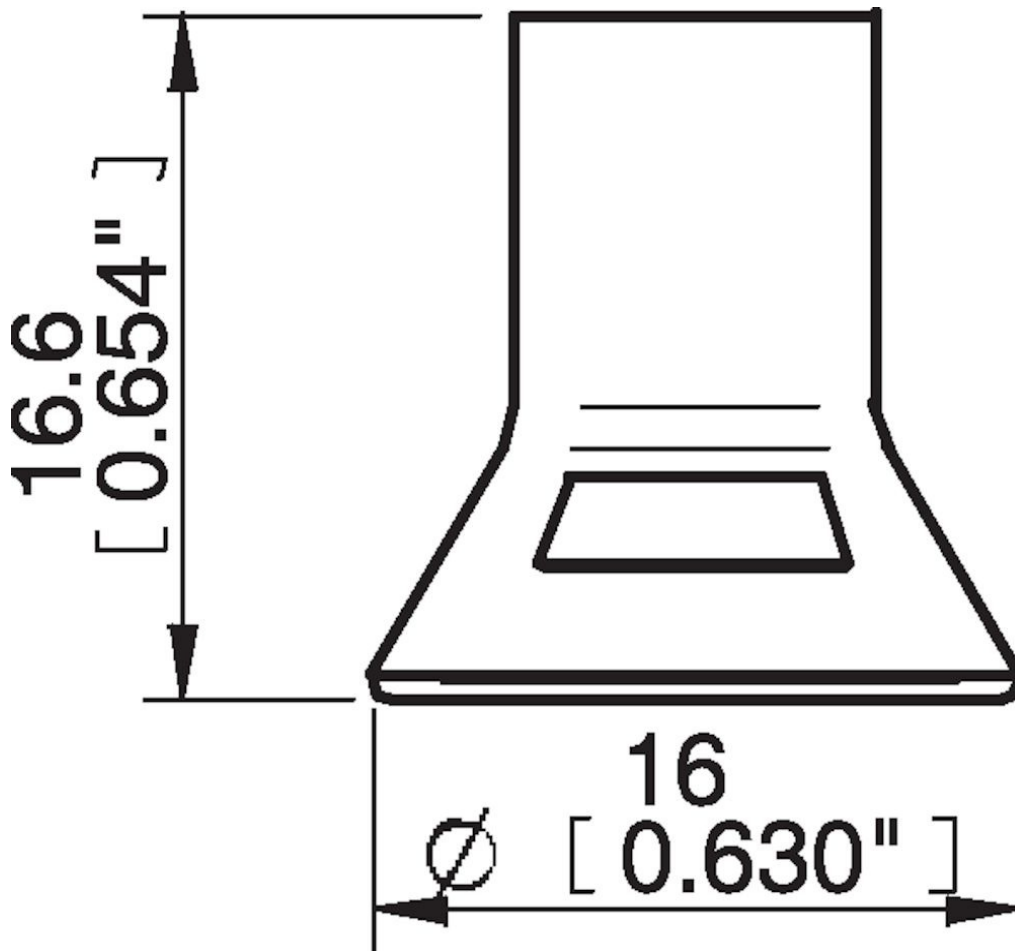

### Values specified in this data sheet are tested at (unless otherwise stated):

- Room temperature (20°C [68°F] ± 3°C [5.5°F]).
- Standard atmosphere (101.3 [29.9 inHg] ± 1.0 kPa [0.3 inHg]).
- Relative humidity 20-70%.
- Compressed air quality, DIN ISO 8573-1 class 4.

### Accessories

3107030 | Fitting M5 male, 10–15