

piINLINE® vacuum generator MICRO Xi, 6-6 mm

Article number: 0122884



- Patented COAX® cartridge technology.
- High vacuum flow capacity in relation to energy consumption.
- Low weight inline design with push-in fittings.
- Quick and easy installation directly on the hose.
- Si/Ti cartridge at 0.6 MPa for extra vacuum flow.
- Bi cartridge for reliability at low feed pressures.
- Ti/Xi cartridge at 0.4/0.5 MPa when high flow and deep vacuum is needed.

Technical data

Description	Unit	Value
Material	-	CuZn, Nitrile (NBR), PA, SS, TPE
Temperature, max.	°C	80
Temperature, min.	°C	-10
Weight, min.	g	9.8
Feed pressure, max.	MPa	0.7
Noise level, max.	dBA	76
Noise level, min.	dBA	70
Length (A)	mm	70

Performance

Feed pressure MPa	Air consumption NI/s	Vacuum flow (NI/s) at different vacuum levels (-kPa)													Max vacuum kPa
		0	10	20	30	40	50	60	70	75	80	90	95	99	
0.5	0.13	0.233	0.15	0.079	0.044	0.036	0.03	0.023	0.013	0	0.007	0	0	0	≥91

Feed pressure MPa	Air consumption NI/s	Evacuation time (s/l) to reach different vacuum levels (-kPa)													Max vacuum kPa
		10	20	30	40	50	60	70	80	90	95	99	99.5	100.3	
0.5	0.13	0.52	1.39	3.01	5.51	8.56	12.32	17.77	27.48	0	0	0	0	0	≥91

Dimensional drawings

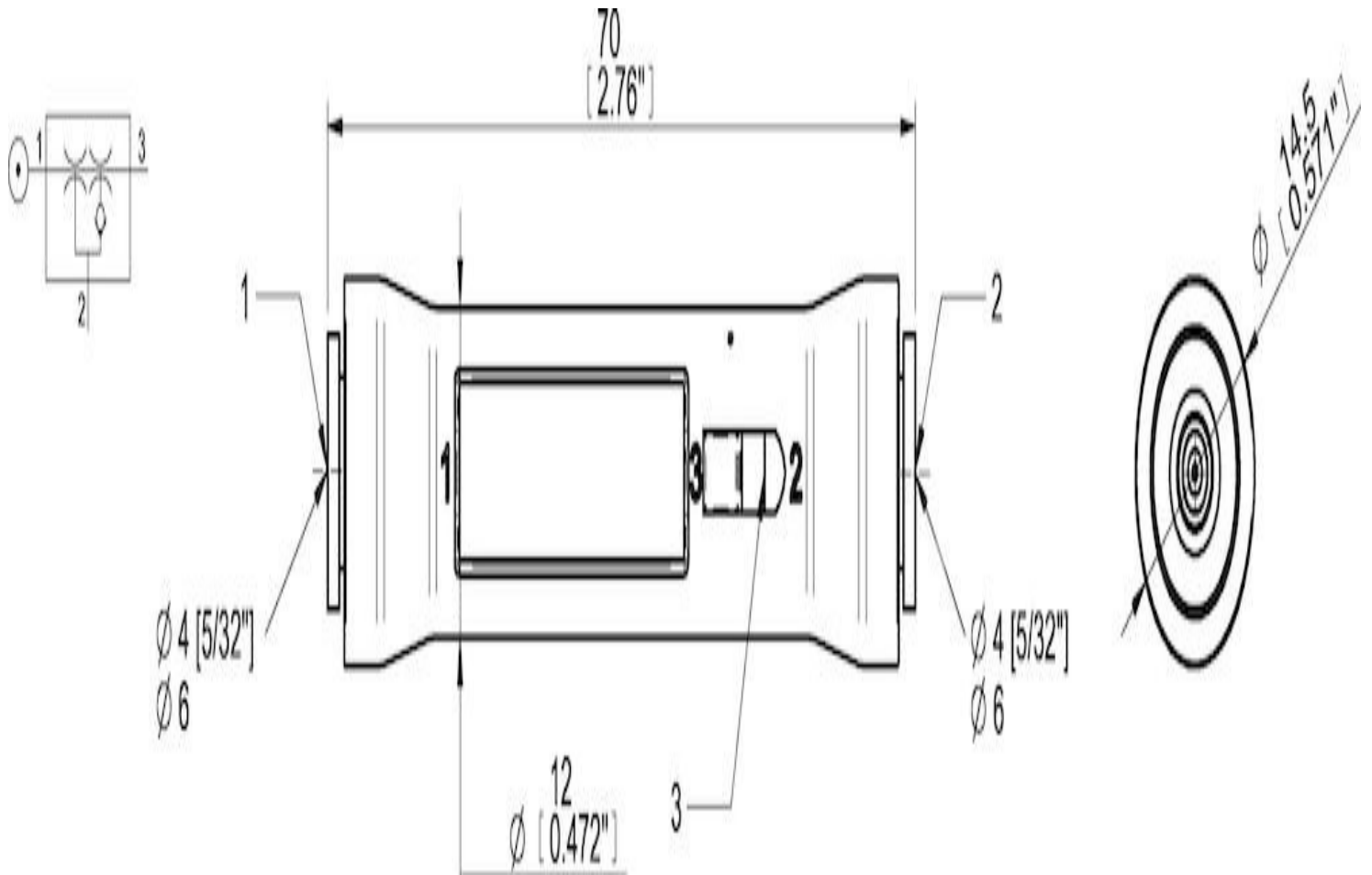

Values specified in this datasheet are tested at (unless otherwise stated):

- Room temperature (20°C [68°F] ± 3°C [5.5°F]).
- Standard atmosphere (101.3 [29.9 inHg] ± 1.0 kPa [0.3 inHg]).
- Compressed air quality, DIN ISO 8573-1 class 4.

Tolerance and accuracy:

- Feed pressure tolerance ±0.02 MPa [2.9 psi]
- Vacuum flow/evacuation time accuracy ±10%.

Accessories

0123093 | Snap-in piINLINE® 5x MICRO mounting bracket