

COAX® cartridge MICRO Si02-2

Article number: 0113591



- Two-stage COAX® cartridge - MICRO - probably the world's smallest multistage vacuum ejector.
- Large vacuum flow in relation to energy consumption.
- Good for handling porous materials or if surface leakage is present.
- The low weight makes it suitable to integrate close to the suction point in high speed pick-and-place applications of small objects.

Technical data

Description	Unit	Value
Material	-	Al, Nitrile (NBR), PA, SS, TPE
Temperature, max.	°C	80
Temperature, min.	°C	-10
Weight, max.	g	2.3
Weight, min.	g	1.5
Feed pressure, max.	MPa	0.7

Performance

Feed pressure MPa	Air consumption Nl/s	Vacuum flow (Nl/s) at different vacuum levels (-kPa)														Max vacuum kPa		
		0	10	20	30	40	50	60	70	75	80	90	95	99				
0.4	0.09	0.25	0.15	0.08	0.07	0.05	0.03	0	0	0	0	0	0	0	0	0	0	≥60
0.5	0.1	0.27	0.19	0.09	0.08	0.07	0.05	0.02	0	0	0	0	0	0	0	0	0	≥70
0.6	0.12	0.28	0.21	0.12	0.08	0.07	0.06	0.04	0.02	0	0	0	0	0	0	0	0	≥75

Feed pressure MPa	Air consumption Nl/s	Evacuation time (s/l) to reach different vacuum levels (-kPa)														Max vacuum kPa		
		10	20	30	40	50	60	70	80	90	95	99	99.5	100.3				
0.4	0.09	0.5	1.37	2.7	4.4	6.9	0	0	0	0	0	0	0	0	0	0	0	≥60
0.5	0.1	0.43	1.15	2.33	3.7	5.3	8.2	0	0	0	0	0	0	0	0	0	0	≥70
0.6	0.12	0.41	1.01	2.01	3.3	4.9	6.9	10.2	0	0	0	0	0	0	0	0	0	≥75

Feed pressure MPa	Air consumption Nl/s	Blow flow (Nl/s) at different pressure levels (-kPa)														Max pressure kPa		
		0	10	20	30	40	50	60	70	80	90	100	110	120	130		140	
0.6	0.12	0.4	0.34	0.22	0.21	0.2	0.18	0.17	0.15	0	0	0	0	0	0	0	0	≥75

Dimensional drawings

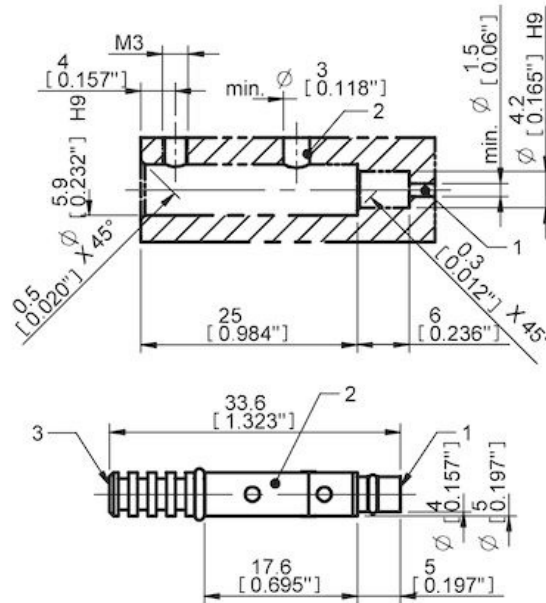
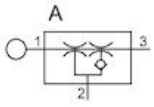

Values specified in this datasheet are tested at (unless otherwise stated):

- Room temperature (20°C [68°F] ± 3°C [5.5°F]).
- Standard atmosphere (101.3 [29.9 inHg] ± 1.0 kPa [0.3 inHg]).
- Compressed air quality, DIN ISO 8573-1 class 4.

Tolerance and accuracy:

- Feed pressure tolerance ±0.02 MPa [2.9 psi]
- Vacuum flow/evacuation time accuracy ±10%.